

PRECAUTION

AIR SPORTS GUNS ARE DESIGNED FOR PERSONS OF AGE 18 OR OLDER FOR SPORTING PURPOSE ONLY AND TO BE OPERATED UNDER THE U.S. FIREARMS SAFETY CODES. THE EFFECTIVE SHOOTING RANGE IS APPROXIMATELY 160 FEET AND CAN BE AFFECTED BY SURROUNDING CONDITIONS, SUCH AS TEMPERATURE, WIND, ETC. IT IS STRONGLY RECOMMENDED TO USE THE AIR SPORTS GUN IN A SAFE DESIGNATED SHOOTING RANGE OR AREA AND TO TREAT ALL AIR SPORTS GUNS AS REAL FIREARMS. AIR SPORTS GUNS CAN BE DANGEROUS AND CAN CAUSE SERIOUS INJURY, IT IS THE USER'S RESPONSIBILITY TO HANDLE AIR SPORTS GUNS IN A SAFE MANNER. BE SURE TO TREAT ALL AIR SPORTS GUNS AS IF THEY WERE LOADED AND NEVER POINT AT ANYONE OR OBJECTS THAT YOU DO NOT INTEND TO SHOOT. ONLY AIM YOUR AIR SPORTS GUN IN A SAFE DIRECTION. U.S. FEDERAL LAW REQUIRES A MINIMUM 6MM ORANGE MARKING ON ANY FIREARM REPLICAS AND BY REMOVING THE ORANGE TIP, YOU ARE VIOLATING THE LAW AND IT CAN ENDANGER YOURSELF AND OTHERS.

THE AIR SPORTS GUNS ARE NOT TOYS, ALTHOUGH THEY FIRE 6MM PLASTIC BB'S AT RELATIVELY LOW VELOCITY, THERE ARE STILL HIGH RISKS FOR PERSONAL INJURY IF PROPER PROTECTIVE GEAR IS NOT WORN. REMEMBER, THE AIR SPORTS GUNS RESEMBLE REAL FIREARMS IN APPEARANCE, SIZE AND SOME FUNCTIONAL RESPECTS, THEREFORE, IT IS RECOMMENDED THAT YOU SHOULD NEVER CARRY OR DISPLAY THE AIR SPORTS GUN IN PUBLIC AREAS. ANY CRIMES COMMITTED WITH AN AIR SPORTS GUN WILL BE PROSECUTED AS IF A REAL FIREARM WERE USED. BE SURE NOT TO POINT THE AIR SPORTS GUNS AT ANY LAW ENFORCEMENT OFFICERS OR ANY OTHER ARMED PERSONS, DOING SO, MAY PUT YOURSELF IN A VERY DANGEROUS SITUATION. **REMEMBER, AIR SPORTS GUNS ARE NOT TOYS.**



ALL USERS MUST WEAR SHOOTING OR SAFETY GLASSES AT ALL TIMES.

- ◆ READ THE OWNER'S MANUAL BEFORE HANDLING AND LOADING THE GUN
- ◆ TREAT ALL AIR SPORTS GUNS AS IF THEY WERE LOADED AT ALL TIMES
- ◆ NEVER POINT AT ANYONE OR OBJECTS YOU DO NOT INTEND TO SHOOT
- ◆ ALWAYS POINT MUZZLE IN A SAFE DIRECTION
- ◆ MAKE SURE YOUR SHOOTING DIRECTION IS FREE OF OBSTACLES BEFORE YOU SHOOT
- ◆ DO NOT LOAD ANY AIR SPORTS GUN UNTIL YOU ARE READY TO FIRE
- ◆ ALWAYS KEEP THE SAFETY ON AND NEVER PLACE YOUR FINGER ON THE TRIGGER UNTIL YOU ARE READY TO FIRE
- ◆ ALWAYS EXAMINE AND UNLOAD THE GUN WHEN NOT IN USE. STORE IT IN A SAFE MANNER AND KEEP AWAY FROM CHILDREN
- ◆ DO NOT PEEP AT THE MUZZLE
- ◆ NEVER SHOOT AT ANY ROCKS, WATER OR ANY HARD SURFACES AS THEY MAY CAUSE THE BB'S TO RICOCHET
- ◆ ALWAYS USE THE PROPER 6MM CALIBER BB'S AND NEVER REUSE BB'S
- ◆ NEVER JUMP, CLIMB OR CROSS OBSTACLES WITH A LOADED AIR SPORTS GUN. ALWAYS UNLOAD THE GUN FIRST
- ◆ NEVER LEAVE A LOADED WEAPON UNATTENDED. AIR SPORTS GUNS ARE CERTAINLY NO EXCEPTION TO THIS RULE
- ◆ ACCIDENTS USUALLY RESULT FROM NEGLIGENCE OF BASIC SAFETY RULES

CHOKING HAZARD! AIRSOFT BB'S CAN BE A CHOKING HAZARD. ALWAYS RETRIEVE BB'S AFTER SHOOTING AND KEEP AWAY FROM CHILDREN.

WARNING! DO NOT ALTER YOUR AIR SPORTS GUN. BY DOING SO, MAY MAKE IT UNSAFE, AND VOID THE WARRANTY, AND AFFECT THE RELIABILITY OF THE PRODUCT.

[1] CHARGING GAS

- (1) RELEASE MAGAZINE BY PRESSING MAGAZINE CATCH.

CAUTION! AVOID MAGAZINE TO DROP FREELY ON HARD SURFACE; IT MAY DAMAGE THE MAGAZINE.

- (2) HOLD MAGAZINE UP SIDE DOWN, RELEASE BASE PLATE LOCK, THEN GENTELY PUSH BASE PLATE FORWARD TO REVEAL CHARGING VALVE.

- (3) PUSH THE GAS CANISTER NOZZLE INTO THE CHARGING VALVE. MAKE SURE THE CANISTER IS IN A VERTICAL POSITION WHEN CHARGING.

- (4) CHARGE MAGAZINE UNTIL GAS OVERFLOWS FROM CHARGING VALVE.

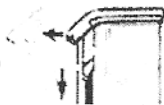

WARNING!

- CHECK CANISTER FOR ANY CRACKS OR LEAKS BEFORE USING
- DO NOT EXPOSE TEMPERATURE OVER 40 °C
- DO NOT LEAVE CANISTER DIRECTLY OVER FIRE
- DO NOT BOIL CANISTER
- KEEP CANISTER AWAY FROM DIRECT SUNLIGHT
- DO NOT LEAVE CANISTERS IN VEHICLES



NOTES: IT IS NORMAL THAT YOU MAY EXPERIENCE MINOR LEAKING FROM CHARGING VALVE DURING CHARGING, DUE TO HIGH PRESSURE BUILT UP INSIDE MAGAZINE. IT IS RECOMMENDED TO KEEP GAS RELEASE VALVE SLIGHTLY OILED. IDEAL TEMPERATURE FOR SHOOTING IS ROOM TEMPERATURE.

CAUTION: YOU MAY EXPERIENCE A DELAY ACTION IF SURROUNDING TEMPERATURE DROPS BELOW 68 °F. REMEMBER, DO NOT EXPOSE MAGAZINE DIRECTLY UNDER THE SUN OR INCINERATE THE MAGAZINE. IT IS STRONGLY RECOMMENDED TO EMPTY GAS FROM MAGAZINE AFTER SHOOTING. BE SURE TO AVOID DIRECT GAS CONTACT WITH EYES OR SKIN WHEN GAS IS BEING RELEASED, IT MAY CAUSE FROSTBITE.

CAUTION: ALWAYS KEEP "SAFETY" ON WHEN LOADING BB'S AND KEEP FINGERS AWAY FROM TRIGGER UNTIL YOU ARE READY TO SHOOT.

[2] LOADING BB'S

- 1- PLACE LOADER PIPE ONTO LOADER FUNNEL
- 2- PLACE LOADER FUNNEL ON TOP OF MAGAZINE LIP
- 3- POUR BB'S ONTO LOADER PIPE. (DO NOT EXCEED 28 BB'S PER-LOADING)
- 4- USE LOADER ROD TO PUSH BB'S DOWN INTO MAGAZINE
- 5- MAKE SURE TO HAVE A 3MM CLEARANCE BETWEEN BB'S AND TOP LIP OF MAGAZINE

NOTE: ALWAYS USE KWA ULTRA PREMIUM BB 0.2 ~ 0.25G. USING ONLY KWA'S ULTRA PREMIUM BB'S CAN GIVE THE AIR SPORTS GUN ITS BEST PERFORMANCE. USING IMPROPER AND LOW GRADE BB'S MAY DAMAGE THE GUN.

[3] LOADING MAGAZINE

- 1- PLACE MAGAZINE BACK INTO MAGAZINE WELL
- 2- PUSH UP MAGAZINE UNTIL IT CLICKS INTO LOCKED POSITION.
- 3- PULL MAGAZINE DOWN TO ASSURE THAT IT HAS BEEN LOCKED IN PLACE.

NOTE: OVERLOADING BB'S IN THE MAGAZINE MAY CAUSE JAMMING AND DAMAGE THE GUN WHEN LOADING. MAKE SURE TO CHECK FOR 3MM CLEARANCE BETWEEN FOLLOWER AND MAGAZINE LIP..

[4] **COCKING**

PULL SLIDE TO THE REARMOST POSITION AND RELEASE THE SLIDE. THIS WILL AUTOMATICALLY LOAD THE FIRST BB'S INTO THE CHAMBER. HAMMER WILL BE IN COCKED POSITION. MAKE SURE NOT TO SKIP THIS PROCEDURE. SKIPPING THIS WILL CAUSE A MISFIRE ON THE FIRST PULL OF THE TRIGGER.

[5] **SELECTOR'S SWITCH**



SEMI AUTO POSITION



FULL AUTO POSITION

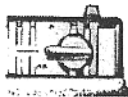

DISASSEMBLE POSITION

WARNING: IT IS RECOMMENDED TO WEAR EYE PROTECTION AT ALL TIMES. BB'S MAY BOUNCE OFF HARD SURFACES (RICOCHET). ALWAYS POINT GUN IN A SAFE DIRECTION.

[6] **SHOOTING**

RELEASE SAFETY AND PULL ON TRIGGER. THE BLOW BACK ACTION WILL LOAD THE FOLLOWING BB'S AUTOMATICALLY AS THE SLIDE CYCLES BACK AND FORTH.

CAUTION: ALWAYS WEAR EYE PROTECTION WHEN SHOOTING. BB'S MAY BOUNCE OFF OF HARD SURFACES. MAKE SURE YOUR SHOOTING DIRECTION IS CLEAR OF OBSTACLES BEFORE YOU SHOOT.

GRASP PISTOL IN YOUR HAND FIRMLY. A TWO HAND HOLD WITH ONE HAND WRAPPED AROUND THE OTHER WILL HELP IN CONTROLLING THE PISTOL.

WARNING: NEVER SHOOT GUN IN A HORIZONTAL OR UPSIDE DOWN POSITION.

[7] **OPEN SLIDE**

AFTER THE LAST SHOT HAS BEEN FIRED AND EJECTED, THE SLIDE WILL REMAIN OPENED. REMOVE MAGAZINE AND RELOAD MAGAZINE WITH BB'S. LOAD MAGAZINE INTO PISTOL AND RELEASE THE SLIDE STOP. SLIDE WILL LOAD THE FIRST BB INTO CHAMBER.

NOTE: IT IS IMPORTANT TO TREAT YOUR GUN AS THOUGH IT IS LOADED, EVEN IF THE SLIDE REMAINS OPEN.

[8] **AFTER SHOOTING**

REMOVE MAGAZINE FIRST AND VISUALLY INSPECT THE OPEN CHAMBER TO CHECK WHETHER THE MAGAZINE WELL AND CHAMBER ARE CLEAR OF BB'S.

M26 *Air Sports Gun*

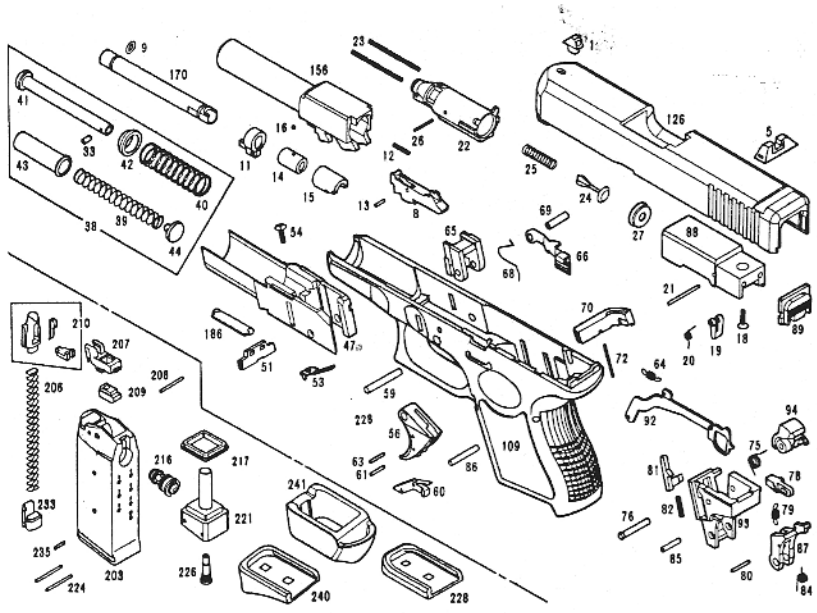

M19 COMMON PARTS

- 1. FRONT SIGHT
- 5. REAR SIGHT "STANDARD"
- 8. INNER BARREL BASE
- 9. BARREL O-RING
- 11. INNER BARREL SLEEVE
- 12. INNER BARREL SPRINGS
- 13. BASE PIN
- 14. CHAMBER
- 15. HOP UP HOOD
- 16. HOP UP BALL
- 18. GAS CHAMBER BLOCK SCREW
- 19. HAMMER RESET BLOCK
- 20. RESET BLOCK SPRINGS
- 21. RESET BLOCK PIN
- 22. GAS CHAMBER CYLINDER
- 23. CYLINDER SPRINGS X2
- 24. GAS CHAMBER PLUNGER
- 25. PLUNGER SPRINGS
- 26. PLUNGER PIN
- 27. GAS CHAMBER SEAL
- 33. END CAP PIN
- 38. RECOIL SPRINGS ASSEMBLY
- 39. INNER SPRINGS
- 40. OUTER SPRINGS
- 41. INNER GUIDE ROD
- 42. GUIDE END CAP
- 43. OUTER GUIDE ROD
- 44. GUIDE END CAP
- 47. INNER FRAME BASE
- 51. SLIDE LOCK UP BLOCK
- 53. LOCK UP BLOCK SPRINGS
- 54. INNER FRAME BASE SCREW
- 56. TRIGGER
- 59. TRIGGER PIN
- 60. TRIGGER SAFETY (NOT INCLUDED)
- 61. SAFETY PIN
- 63. TRANSFER BAR PIN
- 64. TRANSFER BAR SPRINGS
- 65. BARREL LOCK UP BASE
- 66. SLIDE STOP LEVER "STANDARD"
- 68. SLIDE STOP SPRINGS
- 69. TRIGGER PIN SLEEVE
- 70. MAGAZINE RELEASE BUTTON "STANDARD"
- 72. MAGAZINE RELEASE SPRINGS
- 75. HAMMER SPRINGS
- 76. HAMMER PIN
- 78. IMPACT HAMMER BLOCK
- 79. BLOCK SPRINGS
- 80. SEAR PIN
- 81. DISCONNECTOR
- 82. DISCONNECTOR SPRINGS
- 84. SEAR SPRINGS
- 85. SEAR SPRINGS PIN
- 86. HAMMER ASSEMBLY HOUSING PIN
- 87. SEAR
- 88. GAS CHAMBER BLOCK
- 89. SLIDE BACK PLATE
- 89. TRIGGER TRANSFER BAR
- 93. HAMMER ASSEMBLY HOUSING
- 94. HAMMER
- 109. FRAME
- 126. SLIDE
- 156. OUTER BARREL
- 170. INNER BARREL

MAGAZINE

- 203. MAGAZINE CASE
- 206. MAGAZINE SPRINGS
- 207. MAGAZINE LIP
- 208. MAGAZINE LIP PIN
- 209. MAGAZINE NOZZLE SEAL
- 210. MAGAZINE FOLLOWER ASSEMBLY
- 218. MAIN VALVE
- 217. MAGAZINE BASE SEAL
- 221. MAGAZINE BASE BLOCK
- 224. MAGAZINE BASE BLOCK PIN
- 226. MAGAZINE CHARGING VALVE
- 228. MAGAZINE BASE PLATE
- 233. MAGAZINE BASE PLATE LOCK
- 235. MAGAZINE BACK PLATE LOCK PIN
- 240. EXTENDED MAGAZINE BASE PLATE
- 241. MAGAZINE GRIP EXTENSION

WARNING! READ ALL INSTRUCTIONS AND SAFETY RULES COMPLETELY BEFORE USING THIS AIR SPORTS GUN. REMEMBER, "SAFETY BEGINS WITH YOU".