

UNIVERSO SNIPER
AIRSOFT



M4

E-SERIES

6MM AIRSOFT ELECTRIC GUN



VegaForce® Company

No.68, Jianguo 2nd Rd., Xinzhuang Dist,
New Taipei City 242, Taiwan
Phone: + 886-2-22036630
Fax: + 886-2-22036610
sales@gb-tech.com.tw

www.gb-tech.com.tw

Made in Taiwan

Your Dealer

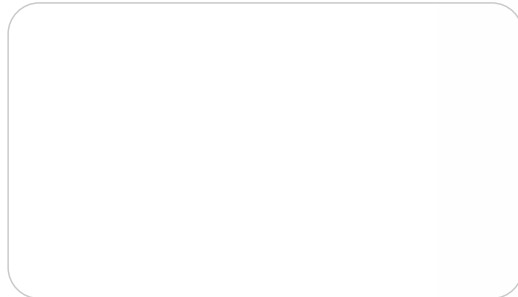

HANDLING CAUTIONS AND INSTRUCTION MANUAL

CAUTION & WARNING

- ▶▶ User restricted to 18 years of age or older !
- ▶▶ Always read through this manual before operation!

CONTENT

1	HISTORY	P.03
2	PROFILES	P.04
3	COMPONENT NAME	P.05
4	SELECTOR LEVER & SAFETY SETTING	P.06
5	SETTING THE BATTERY	P.07
6	LOAD THE MAGAZINE	P.08
7	ADJUSTABLE SIGHT	P.09
8	MOVABLE PARTS	P.11
9	FIRING	P.14
10	VARIABLE HOP-UP SYSTEM	P.16
11	TROUBLE CLINIC	P.18
12	FRONT-END SET PART LIST	P.19
13	RECEIVER SET PARTS LIST	P.21
14	REAR-END SET PARTS LIST	P.22
15	MOVEABLE PARTS LIST	P.23
16	AFTER SERVICE	P.24
17	PARTS AND ACCESSORIES	P.25

WARNING !

Always read through this manual before operation

- **KEEP OUT OF REACH OF CHILDREN.**
- All persons in range must use eye protection when gun is in use.
- Failure to obey all local laws in the use of this replica may result in severe punishment.
- Always point the gun in a safe direction.
- Keep your finger off the trigger until you are ready to fire.
- Never look directly into the gun muzzle.
- Never aim or shoot at persons, animals, or objects.
- Never shoot in or towards public areas.
- Always transport the gun inside of a secure bag or container.



1 HISTORY

The M4 and variants fire 5.56x45mm NATO ammunition and are gas-operated, air-cooled, magazine-fed, selective fire firearms with a 4-position telescoping stock. Original M4 models had a flat-ended telescoping stock, but newer models are now equipped with a redesigned telescoping stock that is slightly larger with curvature at the end. The M4 is similar to much earlier compact M16 versions, such as the 1960s-era XM177 family. Some of those visual designs are obvious in both weapons, however most of the similarities are not very noticeable.

As with many carbines, the M4 is handy and more convenient to carry than a full-length rifle. The price is slightly inferior ballistic performance compared to the full-size M16, with its nearly 6" longer barrel. This becomes most apparent at ranges of 300 yards and beyond. Statistically, however, most small-arms engagements occur within 100 yards. This means that the M4 is very much an adequate weapon for the majority of troops. The marginal sacrifice in terminal ballistics and range, in exchange for greatly improved handling characteristics, is usually thought to be a worthwhile compromise.

While the M4's maneuverability makes it a candidate for non-infantry troops (vehicle crews, clerks and staff officers), it also makes it ideal for close quarters combat (CQC), and airborne and special operations, which is the most popular usage for the weapon. It has been adopted by United States Special Operations Command (USSOCOM) and is the preferred weapon of the U.S. Army Special Forces and Navy SEALs. M4's have also been fielded by the Australian Special Air Service Regiment. Malaysia purchased M4 Carbine service rifles to replace the Steyr AUG service rifles in its armed forces in 2006 and will be manufactured in Malaysia under license by SME Ordnance Sdn Bhd. It is expected that the M4 will be adopted by law enforcement agencies in Malaysia, such as the Royal Malaysian Police and the Malaysian Maritime Enforcement Agency.

The M4 was developed and produced for the United States government by Colt Firearms, which has an exclusive contract to produce the M4 family of weapons through 2009; however, a number of other manufacturers offer M4-like firearms. The M4A1, along with the M16A4, has mostly replaced the M16A2; the U.S. Air Force, for example, plans to transition completely to the M4 Carbine.

The United States Marine Corps has ordered its officers (up to the rank of lieutenant colonel) and (senior) Staff Non-commissioned officers to carry the M4A1 carbine instead of the M9 handgun. This is in keeping with the Marine Corps motto, "Every Marine a rifleman." United States Navy corpsmen will also be issued M4A1s instead of the M9.

2 VFC E-SERIES PROFILE

As the simple living has become the world trend, the concept of **Economic, Enough, Valuable**, has become a new mainstream consumer, VFC naturally should have not stay outside in with this trend. Thus, **E Series** has become the VFC year of 2009 mainly product lines.

VFC is different from the past, invariably to meet the luxury demand of Heavy User. E Series is about the high cost/performance to **Economic, Enough, Valuable**, for the entire idea of the product. In other words, **Take an affordable price in order to provide users with a useful electric gun.**

Appropriate adjusted the part of the process, the process has oversimplified, also to omit excessive packaging; however, the entire product of the metal parts remain metal, the place is still as real steel without losing quality and detail. The most important part of AEG, **GEAR BOX SYSTEM** does not compromise because it's cheaper. We still use precision CNC machining of 8mm gear box, with high-strength pistons and steel gear, making the former settings can be directly using the Li-poly battery. Therefore, the **E Series** AEG is not only high rate of fire (ROF), high performance, easy to use, but also easy to upgrade.

E Series to represent the excellent in value of price, but without losing quality, even greater durability, practical and truly able to meet the majority of players on the VFC brand demand.

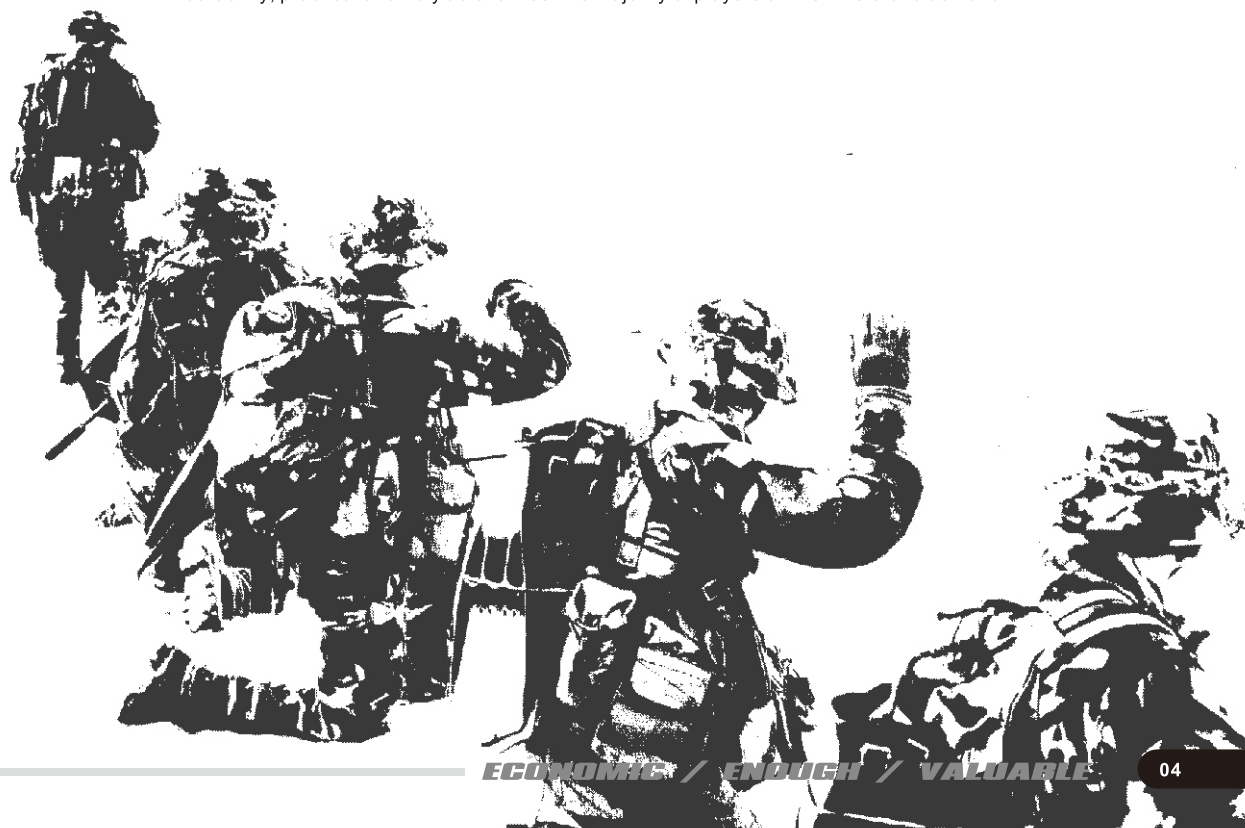

3 COMPONENT NAME

Right Side

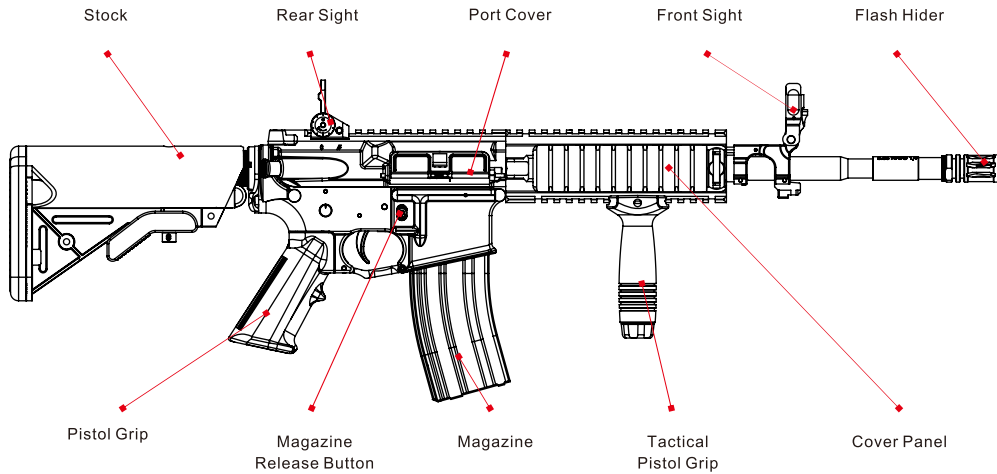

Left Side

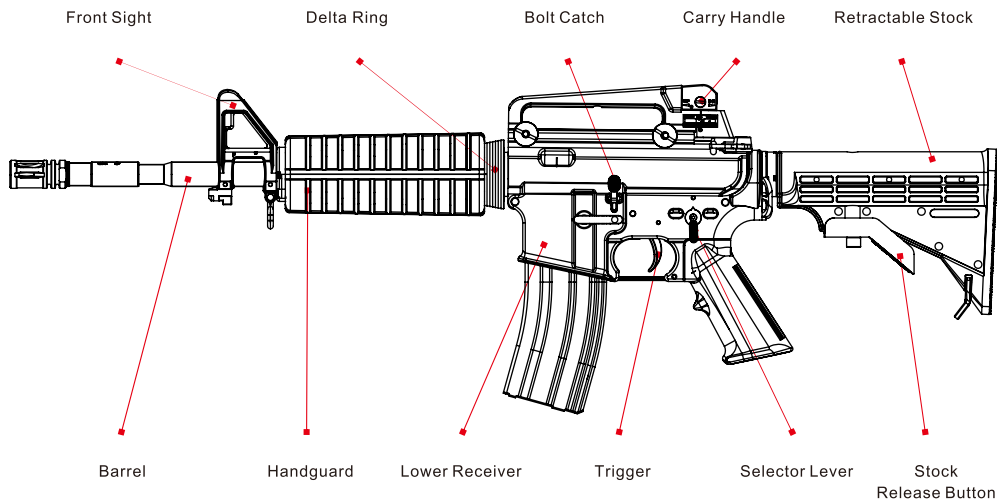

4 SELECTOR LEVER & SAFETY SETTING

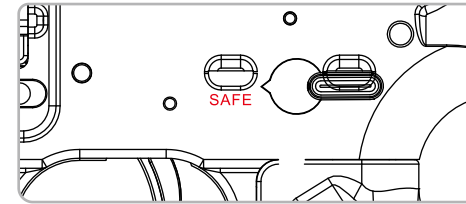

Safety Setting (The trigger can not be pulled)

Always set lever to SAFE position when gun is not in use.

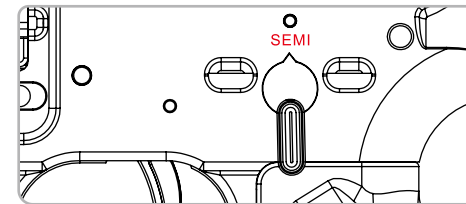

Semi Auto (Single Shot)

The gun will fire one shot each time the trigger is pulled.

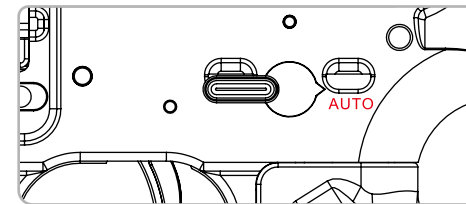

Full Auto (Automatic Shot)

The gun will fire continuously while the trigger is depressed.

WARNING • CAUTION

- Do not operate the selector lever while the trigger is depressed. Damage and malfunction will occur if you attempt to do so.
- Do not pull the trigger while the selector is on SAFE. Doing so will damage the trigger and safety mechanisms.

5 SETTING THE BATTERY

WARNING · CAUTION

Before changing the battery, point the gun in a safe direction, remove the magazine, and set the selector to SAFE.

■ Handguard Type

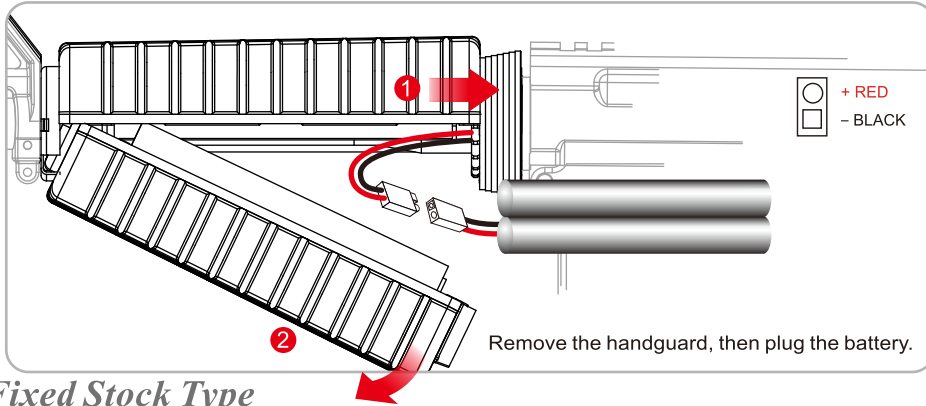

■ Fixed Stock Type

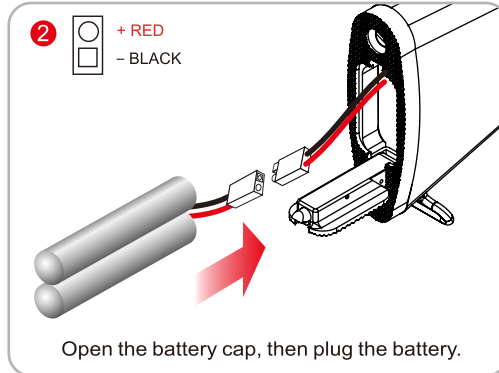
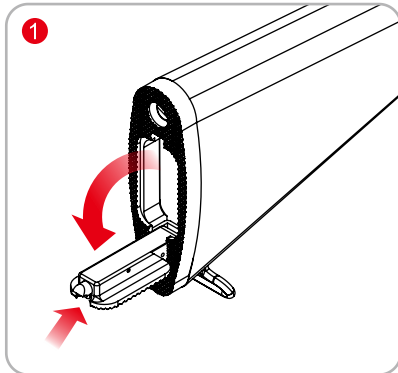

■ SOPMOD Stock Type

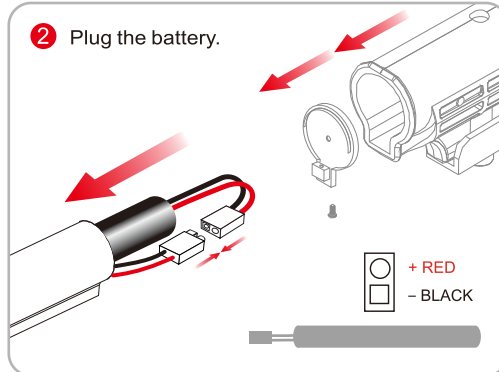
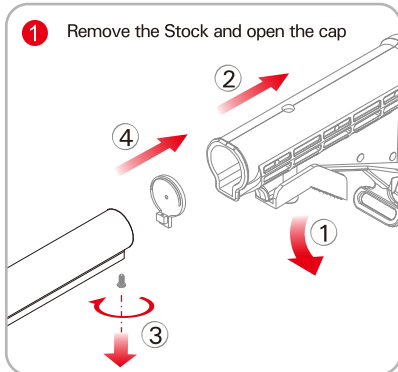

6 LOAD THE MAGAZINE

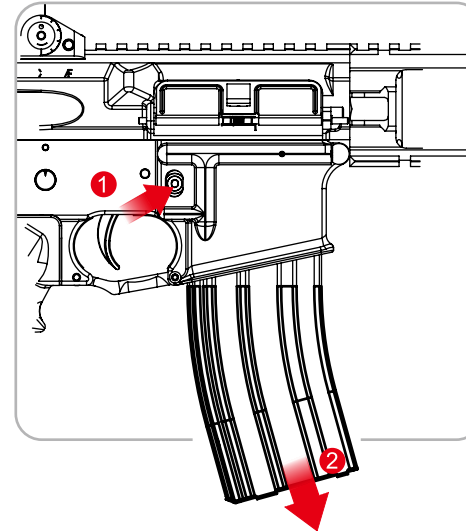

Press the magazine release button to remove the magazine.

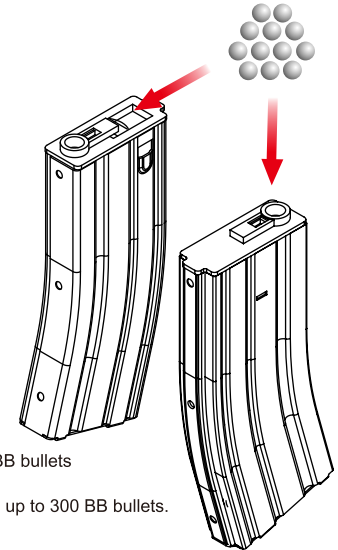

Use only 6mm plastic BB bullets with the magazine.
The magazine will hold up to 300 BB bullets.

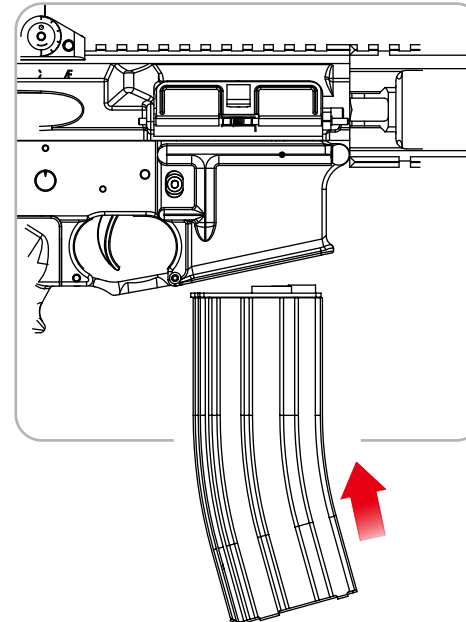

WARNING · CAUTION

- Always use high quality 0.20 gram or heavier BB bullets in your airsoft rifle.

We will not be held responsible for any damage or incidents arising from use of poor quality or underweight BB bullets.

Consult with your dealer for proper BB bullets.

Make sure to set the magazine upwards and connect it firmly until a click sound is heard.

7 ADJUSTABLE SIGHT

■ the Front Sight

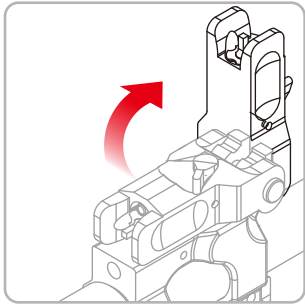

Lift the sight when using.

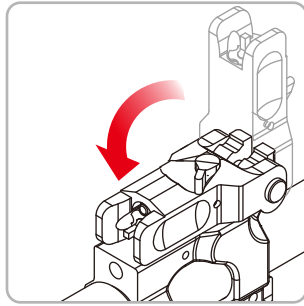

■ the Front Sight

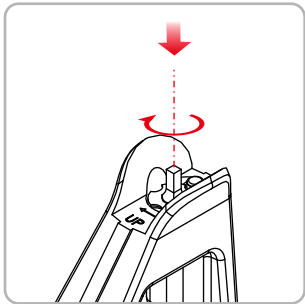

Clockwise: Down the sight post.

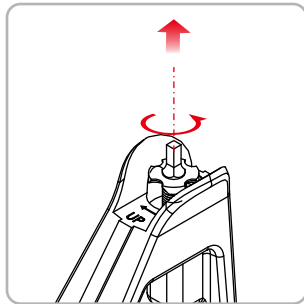
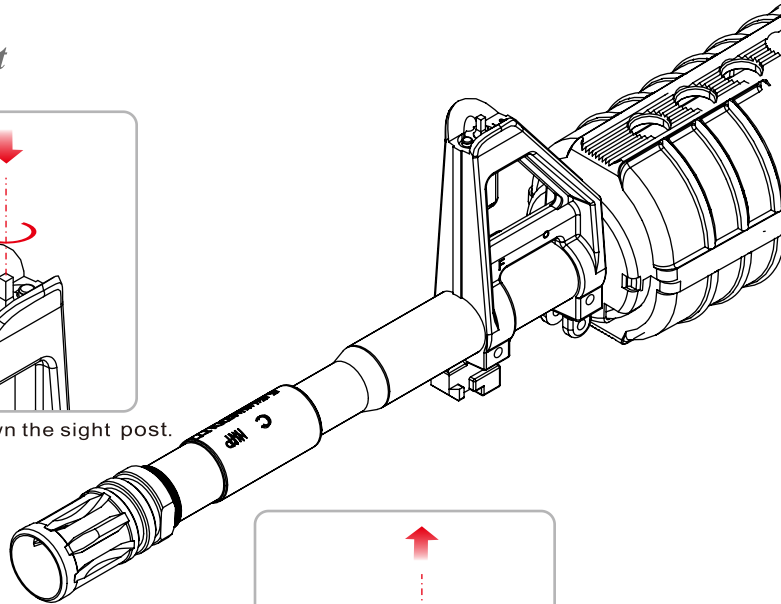

Counterclockwise: Up the sight post.

■ Use the Rear Sight

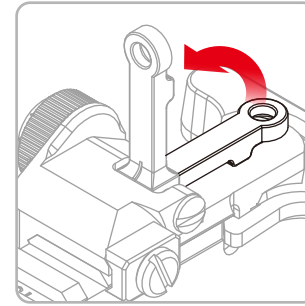

Lift the rear sight when using.

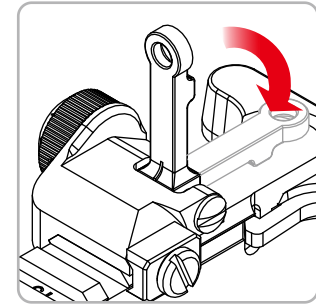

■ Adjustment the Windage Knob

Turn the windage knob for windage adjustment.

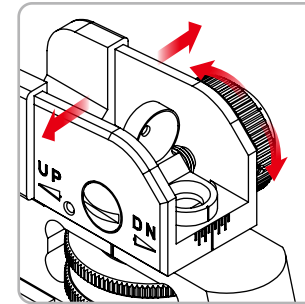

Forward: Move the sight to the right.
Backward: Move the sight to the left.

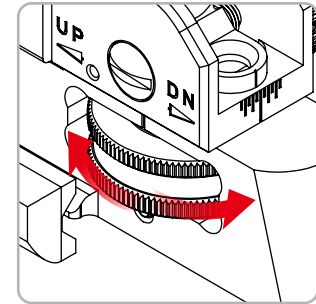

Forward: Up the sight.
Backward: Down the sight.

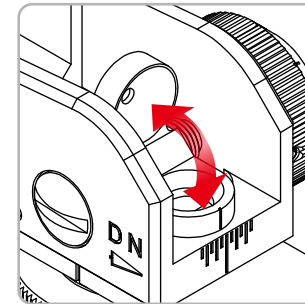

The sight can be flip up and down.

※ Take care not to catch your fingers in moving parts.

8 MOVABLE PARTS

A. Operate the Telescoping Stock

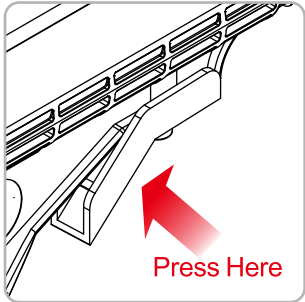

Press the stock release button, then adjust the stock position.

WARNING • CAUTION

- Be careful not to catch your fingers when operating buttstock functions.

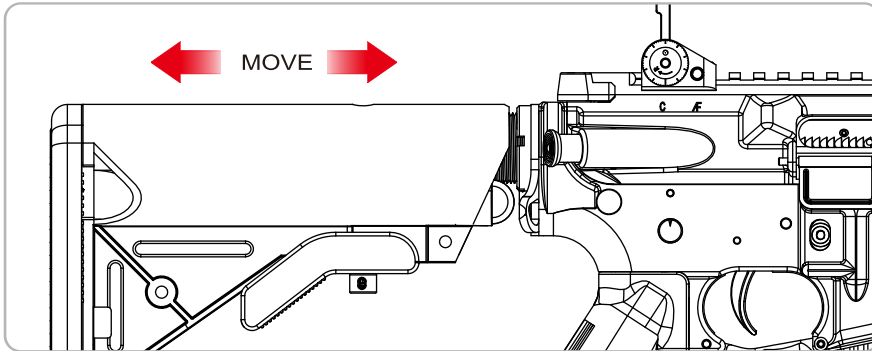

B. Cover Panel Optional parts

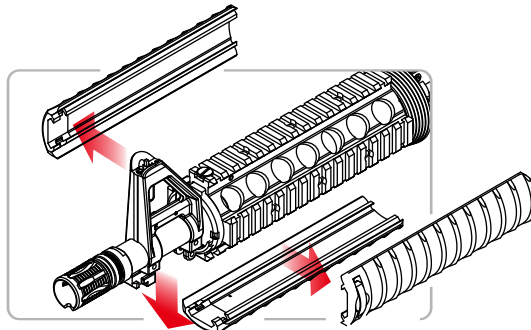
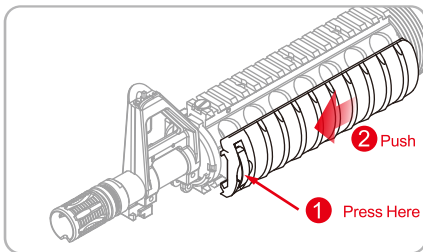

- 1 Pressing the front clips of the rail cover panel toward the center.
- 2 Simultaneously, push the rail cover panel forward and it can be taken out

C. Forward Grip

Optional parts

The knob under the forward pistol grip face down the grip, twist clockwise and then the grip can be taken out.

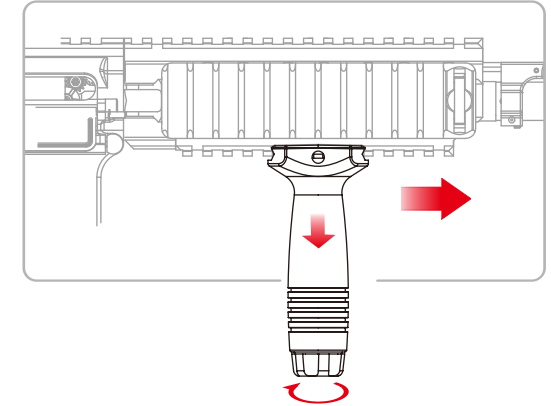

D. Carry Handle

Carry handle can be taken down.

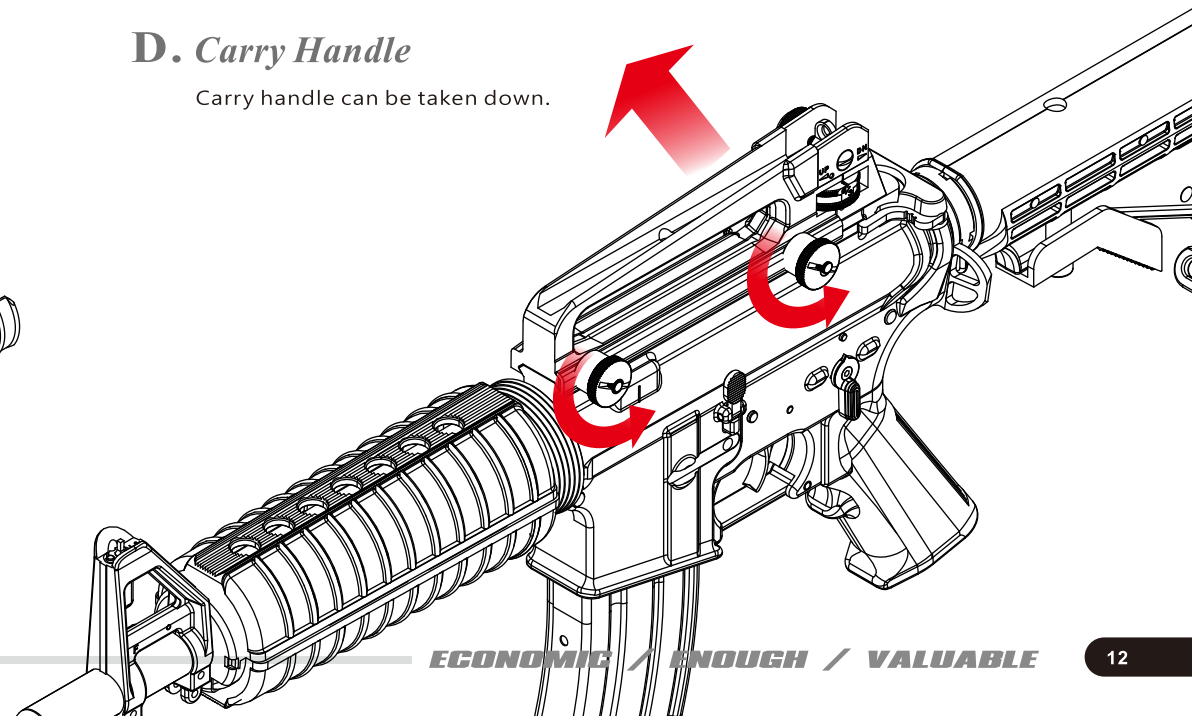

E. Charging and Bolt Catch

The Charging handle can be pulled and the dummy bolt will be fastened.

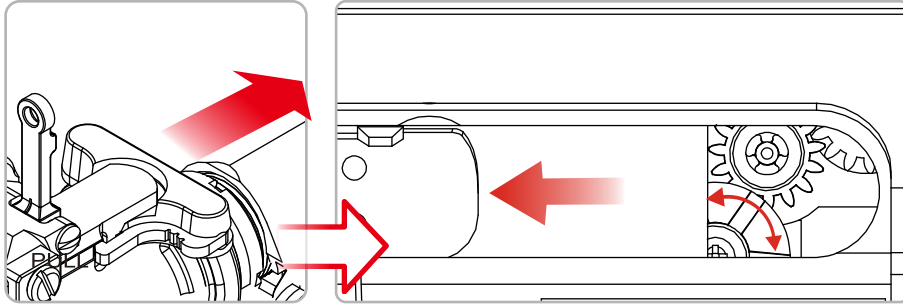

To Release bolt, just press the bolt catch.

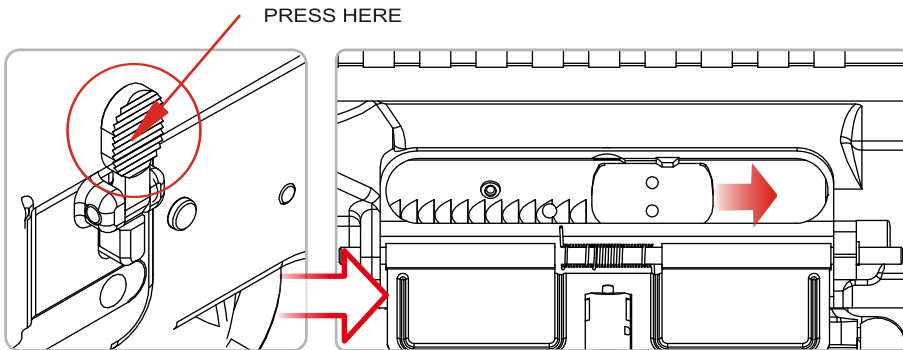

WARNING • CAUTION

- Be carefully and don't get hurt when press the bolt catch.

9 FIRING

Set the Selector lever to "SEMI" or "AUTO".

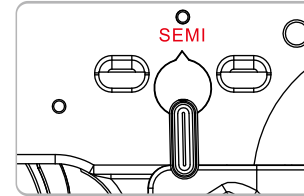

Semi Auto | The gun will fire one shot each time when the trigger is pulled.
(Single Shot)

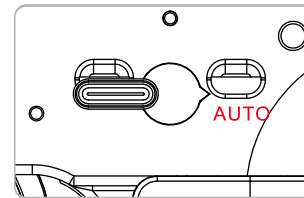

Full Auto | The gun will fire automatically while the trigger remains pulled.
(Automatic Shot)

1. Set the selector lever to Semi-Auto or Full Auto.
2. Pull the trigger.

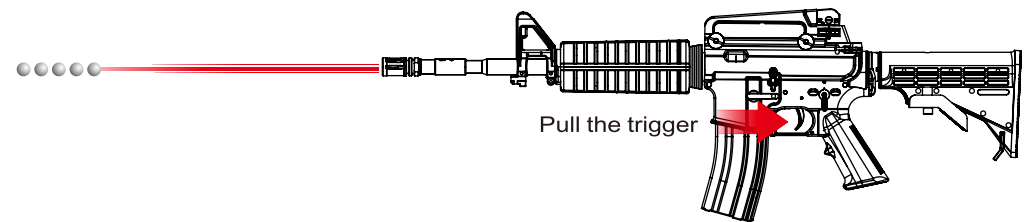

CAUTION

- Never put your finger on the trigger unless you are ready to shoot.

WARNING CAUTION

- Confirm selector is off SAFE before firing the gun.
- Pulling the trigger while the selector is on SAFE will damage the gun and cause it to malfunction.

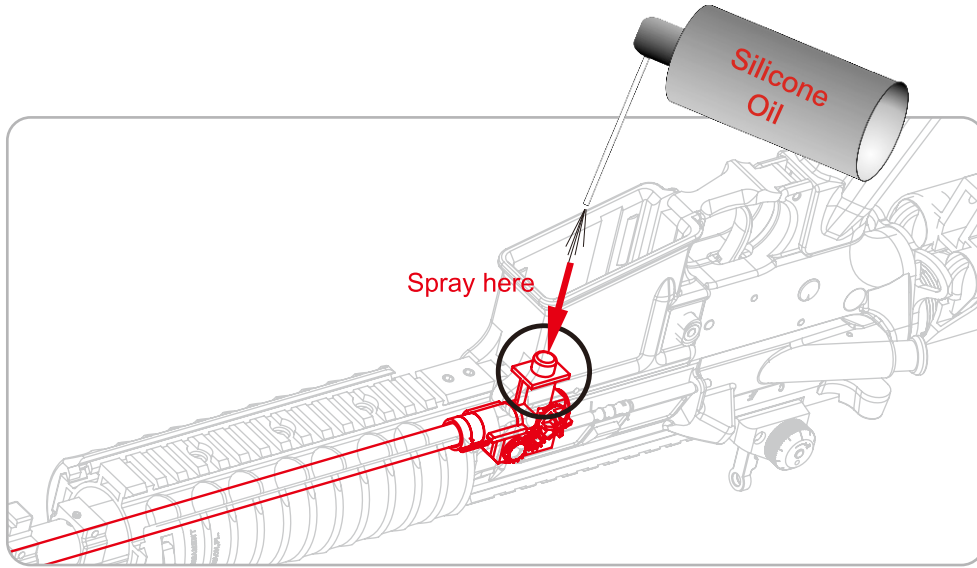

⊙ After Operation

- Point the gun in a safe direction, remove the magazine and fire the gun in semi auto mode to clear the barrel and release the internal spring. Then set the selector to SAFE.
- Be aware a BB bullet may still be in the barrel after the magazine is removed, or if the magazine is empty.

⊙ Cautions on Motor and Battery

- If the rate of fire noticeably drops, recharge the battery or replace with a fully charged one.
- give the air gun a rest for 5 to 10 minutes after firing about 500 rounds, in order to ensure long service lives of the motor and battery.

⊙ When Bullets Are Clogged

- If a BB bullet jam occurs, remove the magazine, and remove the jammed BB bullets with a cleaning rod. Apply a few drops of 100% silicone oil into the chamber and resume shooting. If jamming problems persist, contact your nearest authorized dealers for service.

WARNING • CAUTION

- Never use WD40, CRC556 or other mineral oil.
- Please read the warning on page 1 before shooting.

10 VARIABLE HOP-UP SYSTEM

※Be careful not to catch your fingers in the dummy bolt.

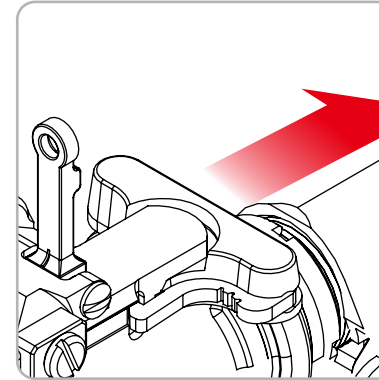

By giving rotation of the fixed direction to BB bullet, a lift is given and it flies horizontally toward a long distance target. Variable Hop-Up system can tune finely that a spin starts.

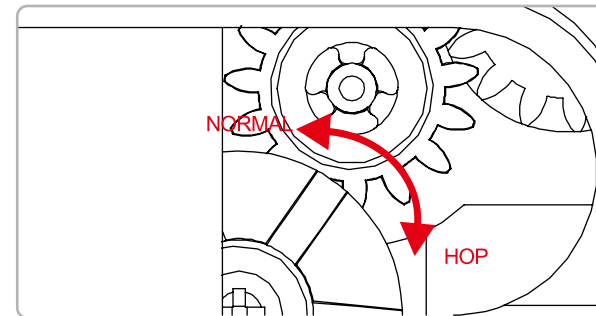
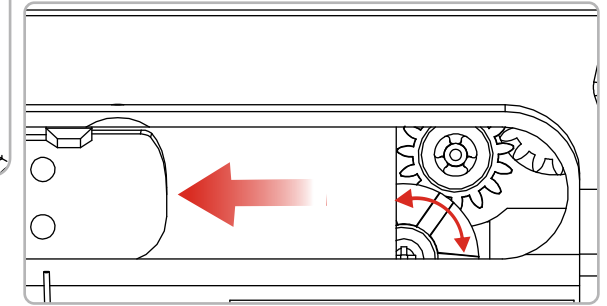

WARNING • CAUTION

- Too much hop up may cause BBs to jam. If a jam occurs, immediately dial back the hop up and test fire again. Otherwise, damage and malfunctions will occur with the gun.

- Open bolt to adjust the Hop-Up system.
- Gradually turn the adjustment dial towards Hop to give hop up to bullets. (The best setting is where bullets fly horizontally.)
- Turning excessively adversely affects the trajectory. So, stop turning the dial when bullets fly horizontally.

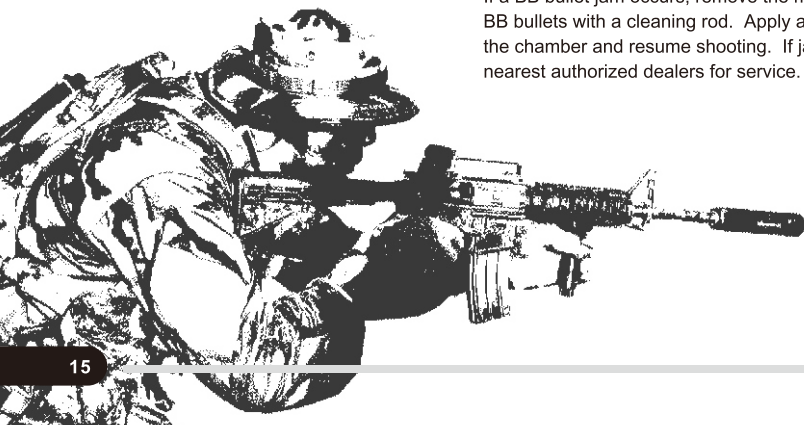

- The best position is where the bullets fly horizontally and the longest flying distance is obtained.

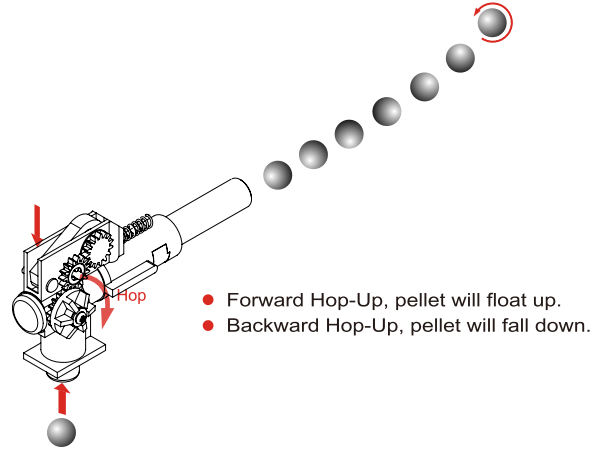
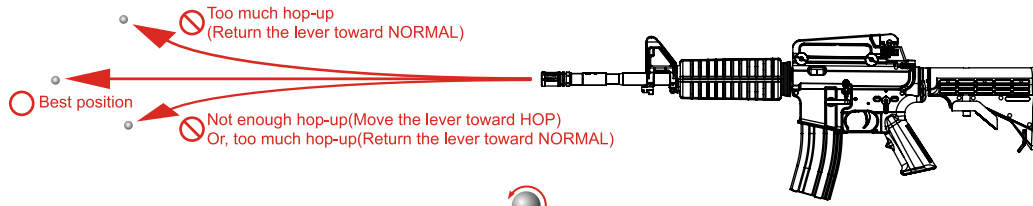

WARNING • CAUTION

- Never hold the gun sideways as the BB bullets will curve right or left. This is due to the Hop-Up system.
- When about 10,000 rounds are fired, spray 100% silicone oil to the chamber for 0.5 to 1 sec.

When HOP-UP is Improper

Symptom	Cause	Action
Bullets flying upwards	Too much hop setting.	Gradually return adjustment lever towards Normal.
Short flying distance of bullets (less hop-up effect)	Too much hop setting.	Gradually return adjustment lever towards Normal.
	Hop packing contaminated by oil or dirt.	Clean using the cleaning rod or consult your dealer or VFC for repair
	Worn or damaged hop packing.	Purchase the replacement part at your dealer or from VFC and replace it.
Can not adjust	Damaged adjustment lever or other parts	Purchase the replacement part at your dealer or from VFC and replace it.
Frequent bullet clogging	Too much hop setting.	After the adjustment lever is returned to anormal side, and the hop is released, it adjusts again.
	Improper or too large sized BB bullets.	Use the BB bullet supplied by VFC.
	Dirty hop packing	Clean using the cleaning rod or consult your dealer or VFC for repair

11 TROUBLE CLINIC

Symptom	Cause	Action
No operation at all	Selector lever is set to safety	Set the selector lever to fire.
	Battery is no charged.	Charge the battery
	Battery connector is disconnected.	Connect the connector
	The + and - of battery connector is reversed.	Connect the connector correctly
	Fuse is blown out.	Replace the fuse.
Although motor is revolving gun does't fire	Bullets are clogged inside the magazine	Insert the charging ord into the maga-zine and move it up and down a few
	Bullets are clogged in the chamber	times to remove clogged bullets. Remove clogged bullets using the cleaning rod.
	Faulty gear	Purchase the replacement gear from your dealer or VFC and repair
Malfunction of full auto operation (automatic firing)	Insufficient battery power	Charge the battery
	Faulty bullet feed of magazine	Repair clogging of the magazine.
Malfunction of semi-auto operation	Poor electrical connection	Consult your dealer or VFC for overhaul maintenance or repair
Malfunction of semi-auto operation (single shot)	Insufficient battery power	Charge the battery
	Poor electrical connection	Consult your dealer or VFC for overhaul maintenance or repair
Automatic firing cycles become slow	Insufficient battery power	Charge the battery
Shooting distance becomes shorter	Worn or damaged chamber packing	consult your dealer or VFC for overhaul maintenance or repair . Replace the chamber packing., piston packing(O-ring) and piston assembly
	Worn or damaged piston packing(O-ring)	
	Deteriorated piston spring	
	Faulty BB bullets (too small or heavy)	Use the genuine VFC BB bullets.
	Shortage of Silicone oil	Drop a few drops of silicone oil from under the chamber
Overly loud operating noise	Gear problems caused by excessive blank firing	consult your dealer or VFC for overhaul maintenance or repair . Replace the chamber packing., piston packing(O-ring) and piston assembly
	Worn of damaged gear	
	Gear problems caused by excessive blank firing	
Bullets falling out from barrel end	Gear problem caused by excessive blank firing	Use the genuine VFC BB bullets.
	Worn or damaged chamber packing	

12 FRONT-END SET PART LIST

- 01 VF9-FHR-M4-01
M4 Flash Hider
- 02 VF9-FHR-VLT-01
Vltor type Flash Hider
- 03 VF9-FHR-M4_2000-01
M4 2000 Flash Hider
- 04 VF9-FHR-AACMK16-01
Mk16 Flash Hider
- 05 VF9-FHR-SB-01
SB Flash Hider
- 06 VF9-FHR-OPS-01
Mark 12 OPS Flash Hider
- 07 VF9-FST-M4-ZN01
M4 Front Sight Base
- 08 VF9-FST-SR16-ZN01
Knight type Flip-up Front Sight with Gas Block
- 09 VF9-GBK-KAC-01
Knight type Gas Block
- 10 VF9-BRL-M4E65-AL01
6.5" Outer Barrel (Baby M4)
- 11 VF9-BRL-M4E75-AL01
7.5" Outer Barrel (Defender)
- 12 VF9-BRL-M4E85-AL01
8.5" Outer Barrel (Quake)
- 13 VF9-BRL-M4E105-AL01
10.5" Outer Barrel
- 14 VF9-BRL-M4E145-AL01
14.5" Outer Barrel
- 15 VF9-BRL-MK12E180-AL01
18" Outer Barrel (Mark 12)
- 16 VF9-BRL-M4E200-AL01
20" Outer Barrel

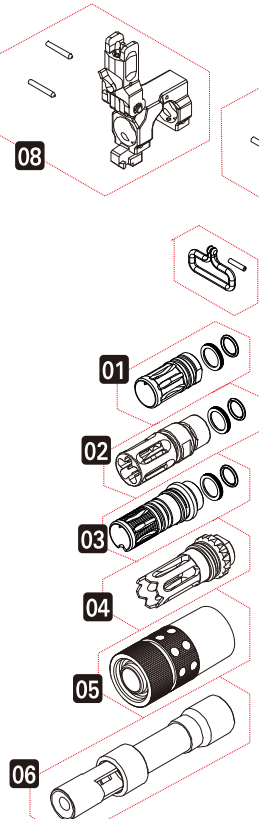

- 17 VF9-BRL-IN168-01
168mm Inner Barrel (Baby M4)
- 18 VF9-BRL-IN208-01
208mm Inner Barrel (Defender)
- 19 VF9-BRL-IN250-01
250mm Inner Barrel (Quake)

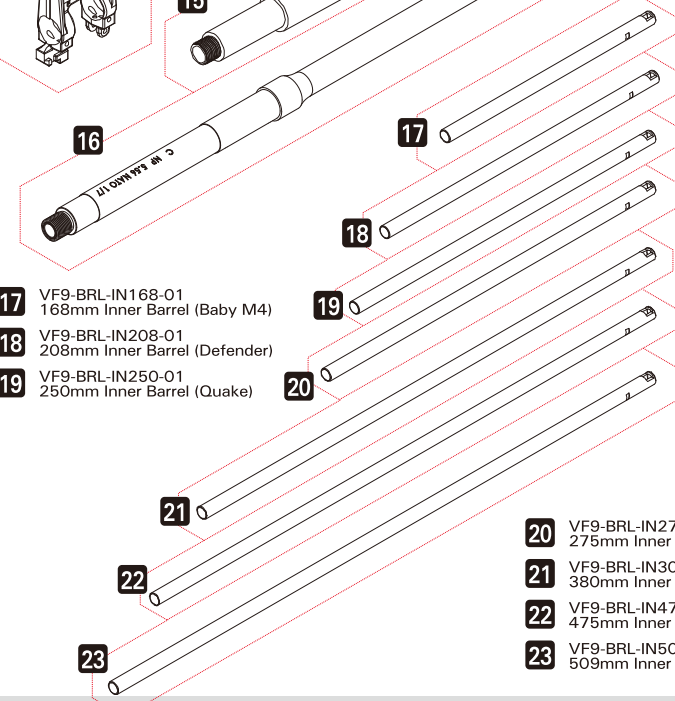

- 20 VF9-BRL-IN275-01
275mm Inner Barrel
- 21 VF9-BRL-IN308-01
380mm Inner Barrel
- 22 VF9-BRL-IN475-01
475mm Inner Barrel
- 23 VF9-BRL-IN509-01
509mm Inner Barrel

- 24 VF9-GPN-M4-210
M4 Gas Tube
- 25 VF9-GPN-M4-350
M16A2 Gas Tube
- 26 VF9-GPN-M4-185
E Series URX 7" Gas Tube
- 27 VF9-GPN-M4-323
E Series URX 12.7" Gas Tube
- 28 VF9-HGD-URX37-BK01
E Series URX 3.7" Handguard
- 29 VF9-HGD-URX70-BK01
E Series URX 7" Handguard
- 30 VF9-HGD-URX95-BK01
E Series URX 9.5" Handguard
- 31 VF9-HGD-URX127-BK01
E Series URX 12.7" Handguard
- 32 VF9-HGD-M4-04
M4 Delta Ring
- 33 VF9-HGC-M4-01
M4 Handguard Cap
- 34 VF9-HGC-M4-02
M16A2 Handguard Cap
- 35 VF9-HGD-M4-01
M4 Plastic Handguard
- 36 VF9-HGD-M4-05
M16A2 Plastic Handguard
- 37 VF9-HGD-RIS-01
Knight type RIS Handguard
- 38 VF9-HGD-RAS120-BK01
Knight type RAS FF Rifle Length

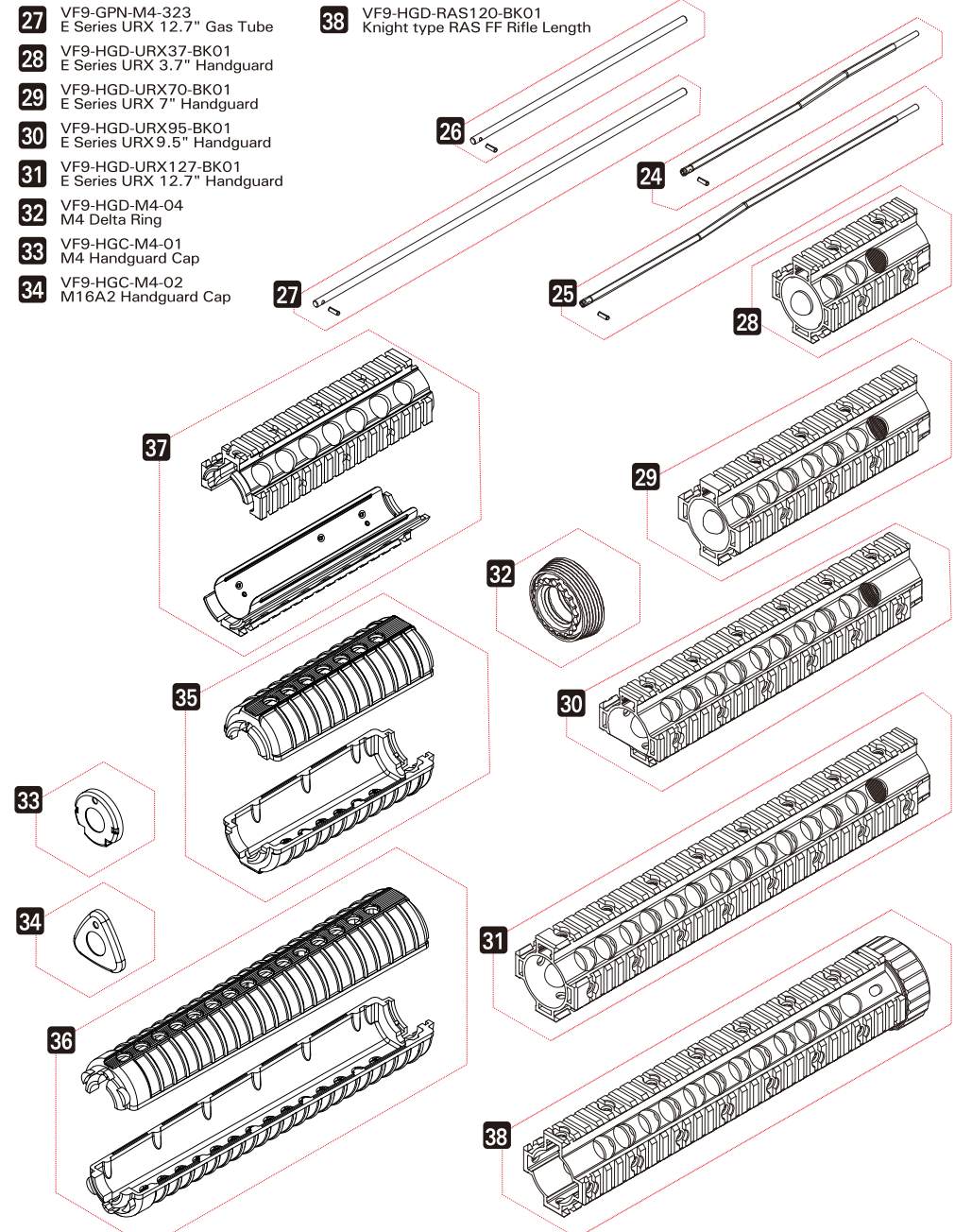

13 RECEIVER SET PART LIST

- 01** VF9-LRV-VFC-BK01
M4 Lower Receiver (Fixed Stock)
- 02** VF9-LRV-VFC-BK02
M4 Lower Receiver
- 03** VF9-LRV-VFC-BK03
M16 Lower Receiver
- 04** VF9-PIN-M4E-02
Front Frame Lock Pin Set
- 05** VF9-PIN-M4E-03
Rear Frame Lock Pin Set
- 06** VF9-MSY-M4E-ZN01
M4 Selector Lever Set
- 07** VF9-PIN-M4E-01
M4 Trigger Lock Pin
- 08** VF9-TGD-M4E-03
Knight type Trigger Guard Set
- 09** VF9-TGD-M4E-02
M4 Trigger Guard Set
- 10** VF9-BCH-M4E-ZN01
M4 Bolt Catch Set
- 11** VF9-MCH-M4E-ZN01
M4 Magazine Catch Set
- 12** VF9-URV-M4E-BK01
M4 Upper Receiver Set
- 13** VF9-BLT-M4E-01
M4 Dummy Bolt Plate Set
- 14** VF9-CHA-M4E-01
M4 Charging Handle Set
- 15** VF9-DCR-M4E-01
M4 Port Cover Set
- 16** VF9-WIR-V2R-05
M4 Battery Wire Set

- 17** VF9-Hop-M4-01
M4 Hop-up Set
- 18** VF9-GBX-V2AF-01
M4 Gear Box
- 19** VF9-GBX-V2AR-02
M16A2 Gear Box
- 20** VF9-GBX-V2AR-01
Baby M4 Gear Box
- 21** VF9-MTR-L-01
Motor Set

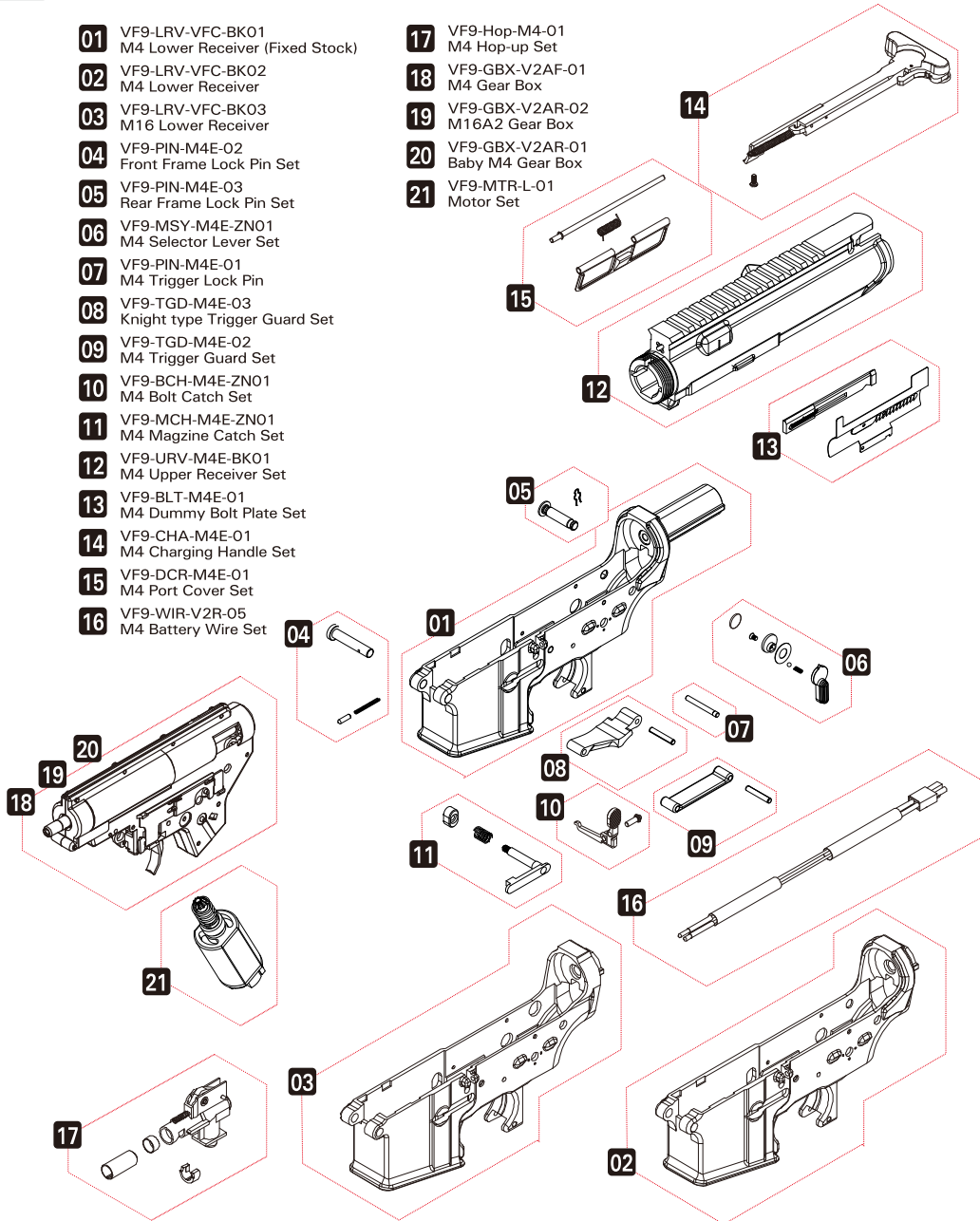

14 REAR-END SET PART LIST

- 01** VF9-SPC-M4E-01
M4 Stock Tube
- 02** VF9-SPC-M4E-02
M4 Stock Tube for LMT type Crane Stock
- 03** VF9-STK-M4-BK01
M4 Retractable Stock
- 04** VF9-STK-LMT-BK01
LMT type Crane Stock
- 05** Magpul MOE Stock (BK/TN)
Not for separately sale
- 06** VF9-STK-M16E-01
M16A2 Fixed Stock
- 07** VF9-GRP-M4E-BK01
M4 pistol Grip Set
- 08** VF9-GRP-M16E-BK01
M16 pistol Grip Set
- 09** VF9-GRP-M16E-BK01
Baby M4 Sling Swivel Adapter

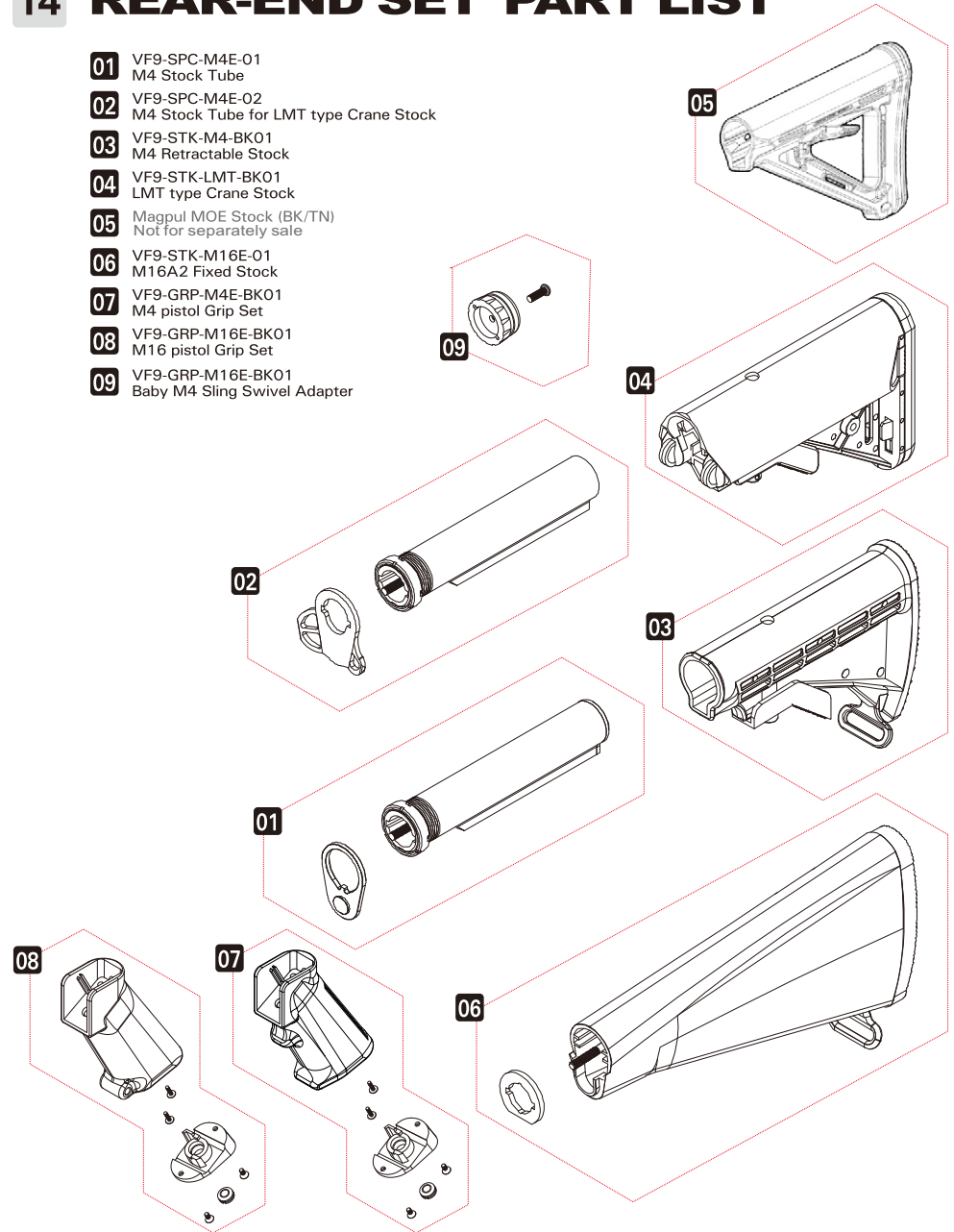

14 MOVEABLE PARTS LIST

- 01** VF9-FST-KAC-BK01
Knight type Flip-up Front Sight
- 02** VF9-RST-300M-BK01
Knight type 300M Flip-up Rear Sight
- 03** VF9-RST-600M-BK01
Knight type 600M Flip-up Rear Sight
- 04** VF9-FST-635-BK01
Knight type Micro Flip-up Front Sight
- 05** VF9-RST-600M-BK02
Knight type Micro 600M Flip-up Rear Sight
- 06** VF9-FST-TroyM4-BK01
Troy type Folding Front Sight (M4 type)
- 07** VF9-FST-TroyHK-BK01
Troy type Folding Front Sight (416 type)
- 08** VF9-RST-Troy-BK01
Troy type Folding Rear Sight
- 09** VF9-RST-LMT-BK01
LMT type Rear Sight
- 10** VF9-RST-M4-BK01
M4 Carry Handle
- 11** VF9-MAG-M4E120-GY
M4 120rd Mid-cap Magazine
- 12** VF9-MAG-M4E300-GY01
M4 300rd Hi-cap Magazine
- 13** VF9-MWS-RP-BK05
Knight type Rail Cover Panel (5 Ribs)
- 14** VF9-MWS-RP-BK11
Knight type Rail Cover Panel (11 Ribs)
- 15** VF9-MWS-FG-BK04
Knight type Foregrip
- 16** VF9-MWS-HS-BK01
Knight type Hand Stop
- 17** VF9-SM-QDRing-02
PDW type QD Sling Swivel

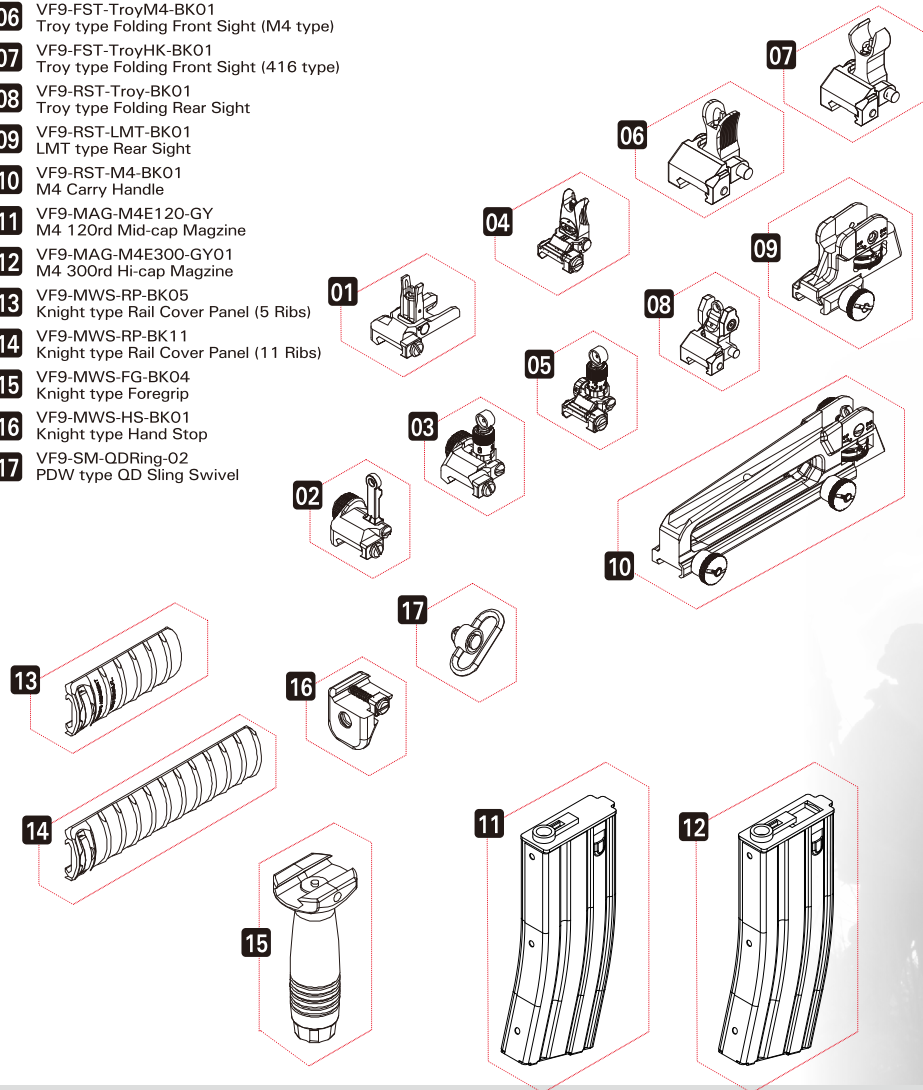

15 AFTER SERVICE

Limited Warranty

- Vega Force Company (VFC) warrants the AEG against defects in materials and workmanship for a period of one month or 30,000 rounds BB bullets shoot from the date of original purchase ("Warranty Period").
- Warranty coverage: Internal parts of gearbox. The cosmetic parts and electric motor are not cover by warranty.
- We inspect and test each product before delivery to customer. In warranty period, the repair service will be provide by ours certify technician after determine the problem or damage defects in materials and workmanship.
- This warranty does not apply: (a) to damage caused by accident, abuse, misuse, misapplication, or non-VFC products; (b) to a product or a part that has been modified without the written permission of VFC or his agent; or (c) to no register your series number with VFC with in 7 days of purchase date; (d) to if any VFC serial number has been removed or defaced; or (e) to disassembly or modify by unauthorized person; (f) to the products not purchase from VFC authorize dealer with valid warranty card.

Maintenance & Replacement Parts

- The Hop-Up bucking and few parts will be recommended to change each 30,000 rounds BB bullets shoot.
- We may unable to provide match series number on replacement parts.
- If you unable to obtain locally, Please check <http://www.gb-tech.com.tw> for more information.



M4 SERIES ACCESSORIES

According to law, this website provides outer kits information which related to toy products is for collection ONLY, NO modify introduction. We also condemn any illegal activities.



Knight SR16 Type Front Sight



Knight type Flip-Up Front Sight



Knight type 14mm Flash Hider



Vitar type Compensator 1st Model Flash Hider



Knight 55566 Type Flash Hider



AAC type Phantom Ring Flash Hider



AAC type SCAR-L3 Ring Flash Hider



AAC type M4-2000 Flash Hider



AAC type MK17 Flash Hider



M4 Flash Hider

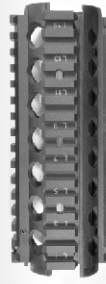

Knight Type R.U.S.



Knight Type L.R.X. (Short Ver.)



Knight Type Free Floating R.A.S. (Short Ver.)

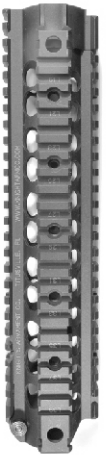

Knight Type L.R.X. (Middle Ver.)

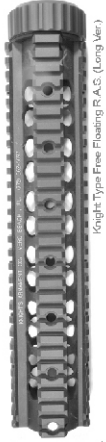

Knight Type Free Floating R.A.S. (Long Ver.)



M16A2 Handguard



M4 Caliber Handguard



Knight One Piece Dual Ring Scope Mount



Willcox type Aimpoint Comp-M Mount



Knight type MMS Forward Rail Mount Base



Knight type Push-Button Swivel



Knight type Sling Swivel Mount (Rear Swivel)



COD type Sling Mount



300M Flip-up rear sight



600M Flip-up rear sight



HK41SD type Rear Sight



LMT type Tactical Adjustable Rear Sight



Curry handle



AR-15 / M4 High Capacity Magazine



Knight type MWS Bipod Adapter



Knight type SR16 Trigger Guard



HK Type Tactical Grip



Knight type Tactical Grip



Knight type M4 Q.D. Suppressor



Knight type SCAR-H Fast-Attach 5.56mm Silencer with Flash Hider



AAC type SCAR-H Fast-Attach 7.62mm Silencer with Flash Hider



OPS 12th Suppressor



OPS 3rd Suppressor



M4A1 / M16A2 Pistol Grip



M16A1 Pistol Grip



LMT type Crane SOPRMOD Stock



HK41SD type Pistol Grip



Knight type Rail Cover Panels



MWS-RP-09



MWS-RP-11

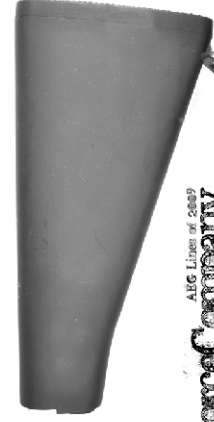

AR15 / M4 Fixed Stock