

# Aftermath Kraken AK-47 Airsoft Rifle

## Owner's Manual

### Aftermath Kraken AK-47 Airsoft Rifle

Metal Gear Box System, High Torque

Motor, Adjustable Hop-up System

Gun Type: Electric

Mode: Semi/Full Auto

HopUp: Adjustable

Caliber: 6mm

Ammo Type: 0.2-0.25g

Capacity: 600 rds

Weight: 6.80lbs

Length: 34.50"



### Kraken AK-47 Name of Parts

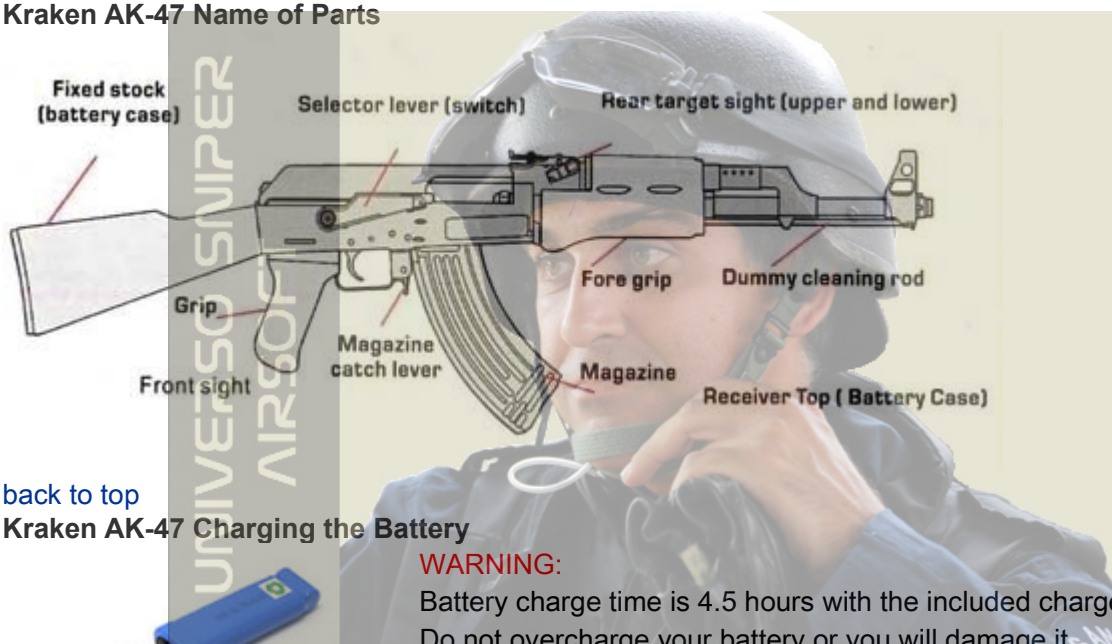

[back to top](#)

### Kraken AK-47 Charging the Battery



#### **WARNING:**

Battery charge time is 4.5 hours with the included charger. Do not overcharge your battery or you will damage it.

(Calculate the proper amount of time required to charge a battery by dividing the battery's milliamp capacity by the charger's charge rate)

The temperature can't exceed over 45 Celcius during charging or will damage the battery

**NOTE:** The manual for the AfterMath guns states that you should charge your battery up to 11 hours. This is incorrect and will result in an overcharge of the battery that may damage your gun and ruin the batteries 'memory.'

[back to top](#)

### Kraken AK-47 Selector Lever and Safety Setting

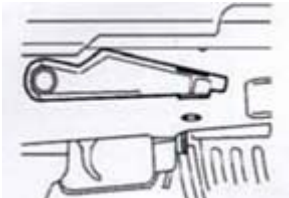

**Warning:** To prevent malfunction of the switch do not change the selector lever from semi to full auto while pulling the trigger.

1. Safety setting (the trigger cannot be pulled)

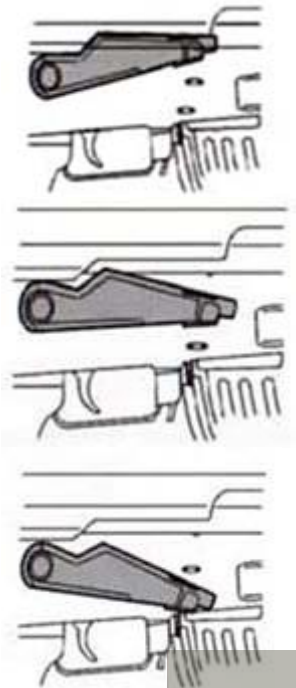

When you are not firing the gun or during storage always set the selector to the safe position.

2. Fully automatic (automatic firing).

The gun will fire automatically while the trigger remains pulled.

3. Semi automatic

The gun will fire one shot each time the trigger is pulled

[back to top](#)

### Kraken AK-47 Setting the Battery

Battery

Battery connection

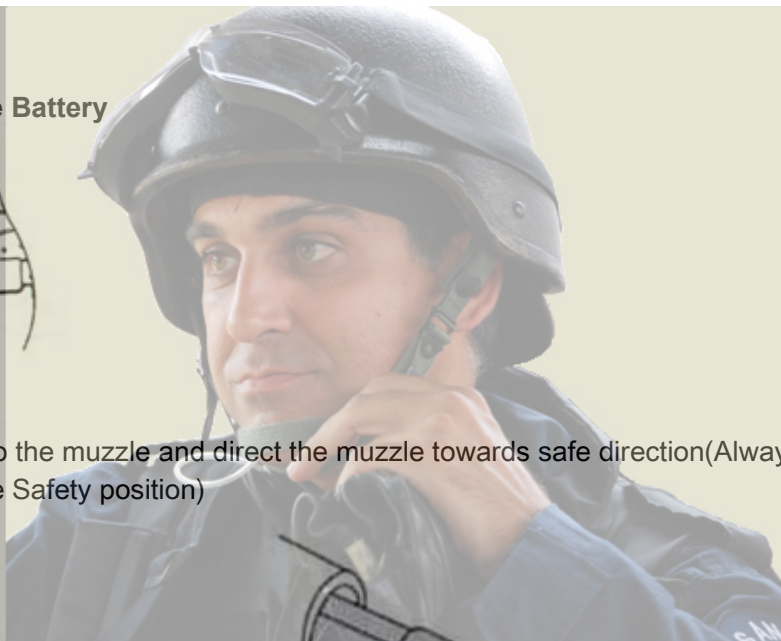
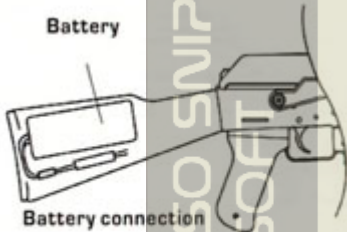

Attach the protective cap to the muzzle and direct the muzzle towards safe direction (Always set the selector lever to the Safety position)

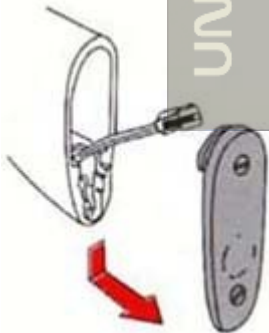

Remove the butt plate by pressing it downwards and pull out the connector.

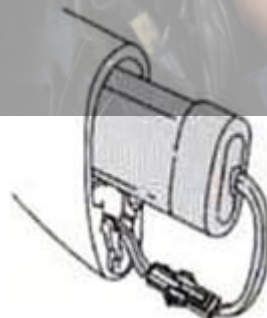

Insert the battery in the stock and connect connectors.

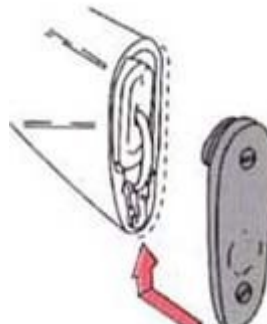
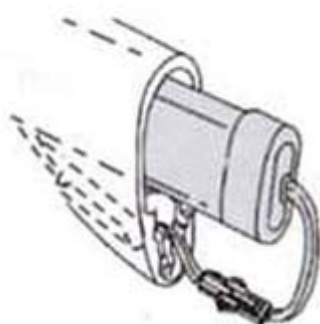

Press down the fuse box and insert connectors and cords between the fuse box and battery. Bend cords in the S shape.

[back to top](#)

### Kraken AK-47 Setting the Magazine

When the battery and cords are set in positions, reinstall the butt plate as shown.



Open the magazine

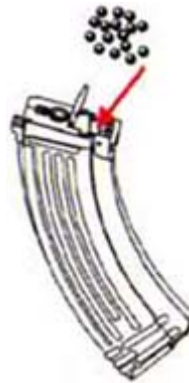

Insert 6mm BB bullets supplied by into the charger. (300 bullets can be inserted.)

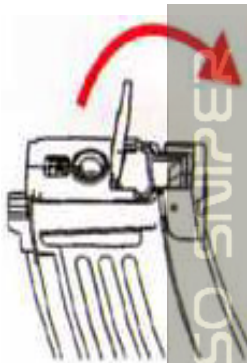

Replace the magazine cover

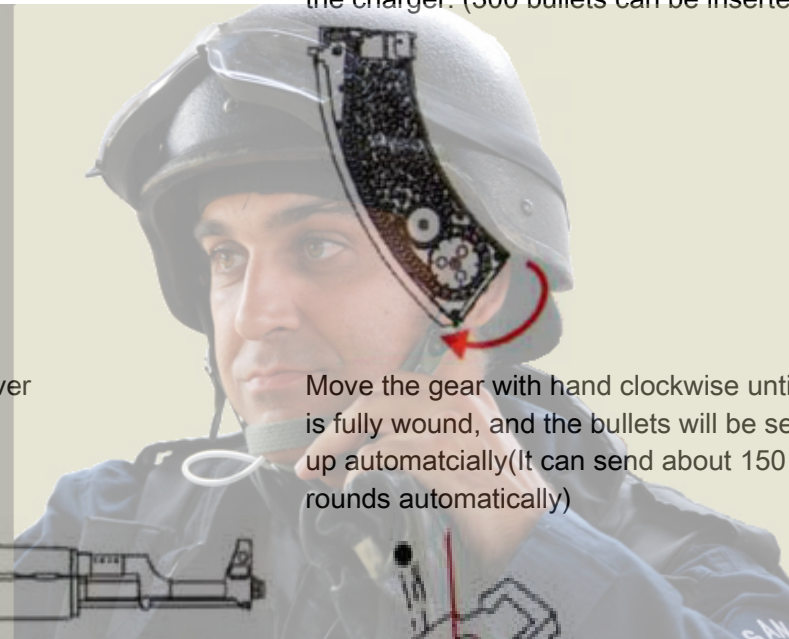

Move the gear with hand clockwise until it is fully wound, and the bullets will be sent up automatically (It can send about 150 rounds automatically)

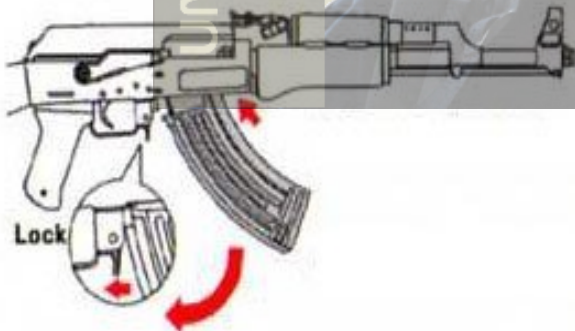

Always set the magazine upwardly. First, align to the groove shown by an arrow and press in the rear of the magazine.

1. First set the front.
2. Press to the rear.
3. Press the release lever towards the trigger to lock.

[back to top](#)

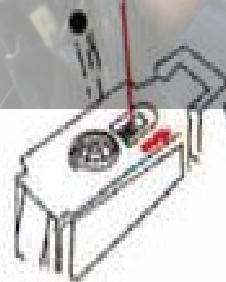

Slide the rib in the arrow direction to remove remaining BB bullets. (Be careful since B bullets may jump out.)

## Kraken AK-47 Rear Sight Adjustments

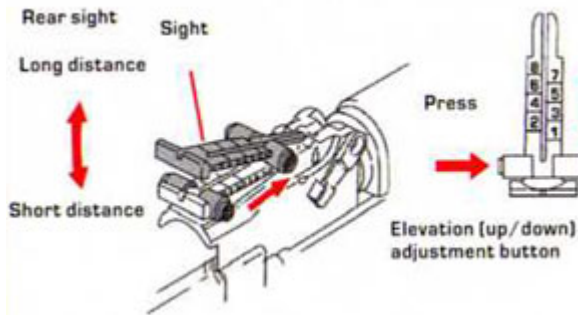

The 028 series rear sight is a tangent type which is adjusted vertically according to distance to the target.

Press the adjust button and slide it forward or backward to move the sight up or down. The larger the number, the longer the distance to the target.

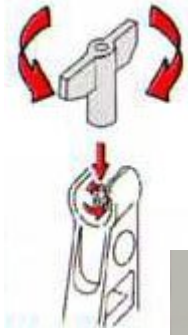

Insert the front sight adjustment tool in the front sight and turn it for adjustment.

Counterclockwise: lower sight point  
Clockwise: higher sight point

**Caution:** Be careful so as not to lose the adjustment tool.

[back to top](#)

## Kraken AK-47 Movable Parts

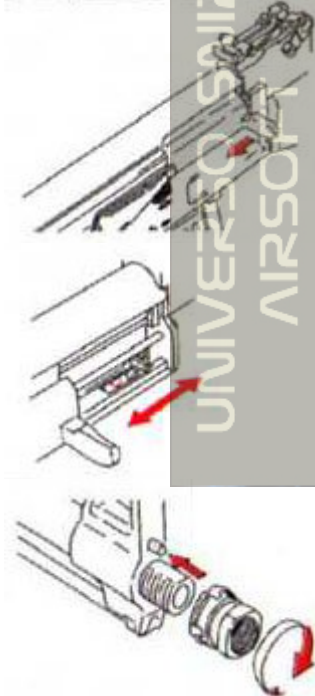

The cocking lever can be moved.

Variable hop-up adjustment lever.

The multi protector is fixed by reverse thread as in the case of the real gun.

1. While pressing the lock button.
2. Remove by turning the multi protector.

[back to top](#)

## Kraken AK-47 Firing



1. Set the selector lever to Semi or Full Auto.
2. Pull the trigger.

**Caution:**A blank firing may occur at triggering after the magazine, this is normal operation of the gun.

**Cautions on Motor and Battery**

Charge the battery if the firing cycle becomes slow. Give the air gun a rest for 5 to 10 minutes after firing about 500 rounds, in order to ensure long service lives of the motor and battery.

**When bullets are clogged**

If bullets are clogged, remove them and apply a few drops of silicone oil into the chamber from the magazine entrances shown or spray silicone oil for 0.5 to 1 sec, to obtain smooth continuous

**Caution**

There are possible cases that no firing occurs after pulling the trigger in the semi-auto mode. In this case, do not pull the trigger furiously. Fire 5 to 6 shots in the full auto mode and then return to the semi auto operation.

Smell may be generated from motor for a while when a new air gun is operated. This is the normal operation of the gun.

The hopping up operation may be unstable for 200 to 300 rounds after using silicone oil, this is the normal operation of the gun.

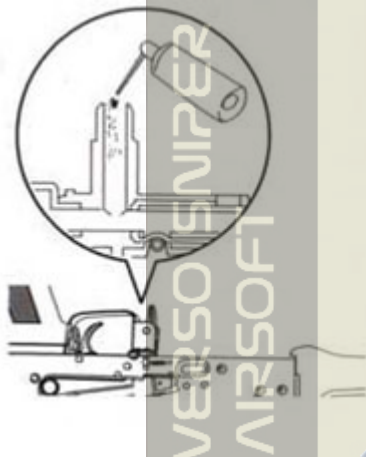

**After Operation**

Remove the magazine and dry fire the gun in the semi auto mode directing the muzzle to a safe direction. (Otherwise the spring may be weakened.) Set the selector to the Safe position.

Bullets may remain in the chamber even if the magazine contains no bullets (or if the magazine is not connected) (Two or three bullets may drop from the magazine, this is the normal operation of the gun.)

Always disconnect the battery and attach the protective cap whenever you do not operate the gun.

**Always attach the protective cap during storage**

[back to top](#)

**TROUBLE CLINIC (Troubleshooting)**

Symptom	Cause	Action
No operation at all	Selector is set to safety.	Set the selector lever to Semi or Full Auto.
	Battery is not charged.	Charge the battery.
	Battery connector is disconnected.	Connect the connector.
	The + and - or battery connector is reverse.	Connect the connector correctly (check the fuse)
	Fuse is blown out.	Replace the fuse.
Although motor is moving, no bullet jump out.	Expired motor life (50,000 to 60,000 rounds) or poor electrical connection.	Replace the motor (purchasing from your dealer or check and repair the contacts)
	BBs are clogged in the magazine.	Insert the charging rod into the magazine and move up and down a few times to remove clogged bullets.
	BBs are clogged in the chamber.	Remove clogged bullets using the cleaning rod.
Impossible full-	Faulty gear	Purchase the replacement gear from your dealer and repair.
	Insufficient battery power	Charge the battery

Faulty BBs feed of magazine      Repair clogging the magazine.

Impossible semi-auto operation (single shot)      Poor electrical connection      Consult your dealer for overhaul maintenance or repair.  
 Deviation in gear timing      Set to semi auto after firing 5 to 6 rounds in full auto.

**Use of poor quality BB bullets will cause problems. Never disassemble or modify the gun.**

Symptom	Cause	Action
Impossible semi-auto operation (single shot)	Insufficient battery power	Charge the battery
Automatic firing become shorter.	Poor electrical connection.	Consult your dealer or us for overhaul maintenance or repair.
Automatic firing become shorter.	Insufficient battery power	Charge the battery
Shooting distance become shorter	Worn or damaged chamber packing (O-ring)	Consult your dealer for overhaul maintenance or repair. Replace the chamber packing, piston assembly.
	Worn or damaged chamber packing.	
	Deteriorated piston spring	
	Faulty BBs (too small or too heavy)	Use genuine BBs.
	Shortage of damaged gear	Drop a few drops of silicone oil from under the chamber.
	Gear problem caused by too many blank firing	Consult your dealer for overhaul maintenance, part replacement (gear, etc.) or repair.
Too loud operating noise	Gear problem caused by too many blank firing	
Bullets being fallen out from barrel end	Worn or damaged chamber packing	
	NO hop setting	Turn the hop adjustment lever toward HOP
	Faulty BBs (too small)	Use genuine BBs.
Being wet by or dropped into water (rain)	Stop operation immediately, disconnect the battery, wipe off water from inside the main body and the battery, and, after complete dry, carry out trial firing. If no operation or malfunction is detected, consult your dealer or us for repair.	

[back to top](#)

**Variable Hop Up System**

By producing a back-spin to the BB bullets, this system allows for straighter and longer distance shooting than normal air gun. Unlike the fixed type, the variable hop up system permits one-touch adjustments using the dial and lever, making it an ideal hop up system.

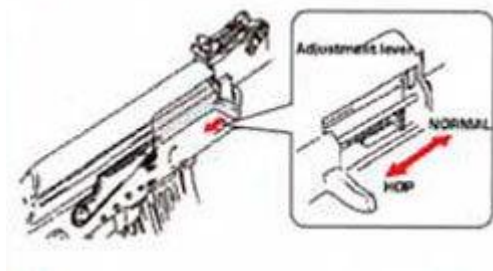

Adjustment Procedure (Adjust by carry out trial firing)

Gradually turn the adjustment dial towards Hop to give hop up to bullets. (The best setting is where bullets fly horizontally.)

Turning excessively adversely affects the trajectory. So stop turning the hop adjustment lever when bullets fly horizontally.



The best position is where the bullets fly horizontally, and the longest flying distance is obtained.

Too much hop-up (return the lever towards NORMAL)

Straight best position

Not enough hop-up (return the lever towards NORMAL)

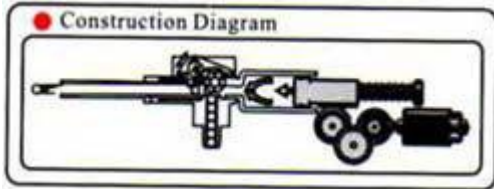

**Operational Caution: Strictly observe the following caution)**

Moving the lever too much towards HOP causes bullets to clog. Firing the gun with clogged bullets damages the piston and gears.

If bullet clogging occurs, immediately stop firing the gun, return the hop lever to the Normal positioning and remove clogged bullets using cleaning rod.

Make sure to return the hop adjustment lever to the Normal position when removing clogged bullets or cleaning. (Otherwise, the chamber packing is damaged.)

Never use used or dirty bullets. (Otherwise, the chamber becomes dirty, resulting in unstable hopping up.)

When about 10,000 rounds are fired, spray silicone oil into the chamber for 0.5 to 1 sec. The hopping up operation may be unstable for 200 to 300 rounds after spraying the silicone oil, this is the normal operation of the gun.)

We will not be held responsible for any damage or accidents arising from wrongful operation, disassembly and modification of the gun. Any costs for repair of such damage shall be paid by the user.

**Caution:** If the hop-up is adjusted excessively causing clogging of bullets, immediately stop operating the gun. Return the lever to Normal, fire to 2 or 3 shots and readjust.

Since a precision tight barrel is used, use of dirty bullets or those with burrs causes clogging of bullets and possible fatal damage to the mechanical box and system.

**Warning: Never hold the gun side ways the Bb bullets will curve right or left. This is due to the HOP-UP adjustment.**

[back to top](#)

#### When Hopping Up is Improper

Symptom	Cause	Action
Bullets flying upwards.	Too much hop setting	Gradually return adjustment lever towards normal
Short flying distance of bullets (less hopping up effect)	Too much hop setting Hop packing contaminated by oil or dirt. Worn or damage hop packing	Gradually return adjustment lever towards Normal. Fire bullets equivalent to 4 or 5 magazine or clean the chamber using cleaning rod Purchase the replacement part at your dealer
Cannot adjust	Damaged adjustment lever or other parts	Purchase the replacement part at your dealer and replace it.
Frequent bullets	Too much hop setting	Gradually return adjustment lever towards

clogging

normal.

Improper or too large sized BB bullets Use the BB bullets for Electric Gun.

BB bullets

Dirty hop packing

Clean using the cleaning rod or consult your dealer for repair.

[back to top](#)

### Kraken AK-47 Maintenance



#### 1. Fuse replacement procedure

The fuse box comes out when the connectors are pulled out of the stock.

When the fuse is replaced, push into the stock all the way.

#### 2. Removing Clogged Bullets (Set the Safety button to ON and remove the magazine beforehand.)

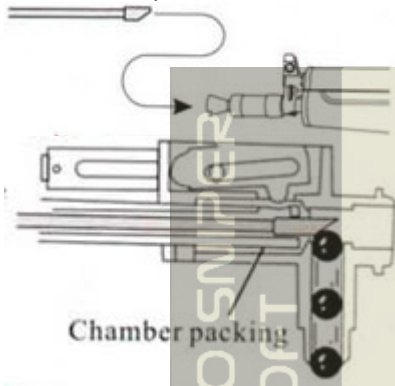

Insert the Cleaning rod into the bore.

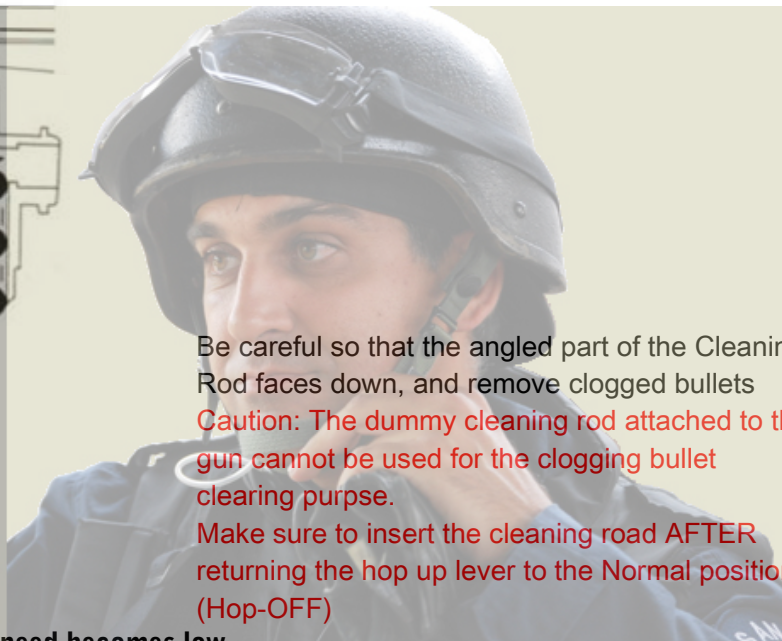

Be careful so that the angled part of the Cleaning Rod faces down, and remove clogged bullets

**Caution:** The dummy cleaning rod attached to the gun cannot be used for the clogging bullet clearing purpose.

Make sure to insert the cleaning rod **AFTER** returning the hop up lever to the Normal position. (Hop-OFF)

#### 3. Maintenance when ball speed becomes low

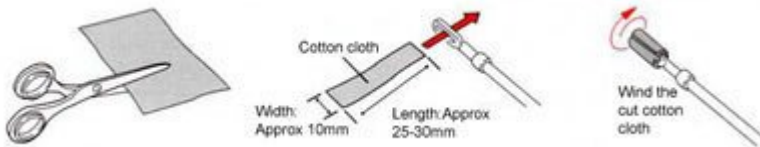

Cut the cotton to the size shown. Adjust the length accordingly so that it can be inserted smoothly into the barrel.

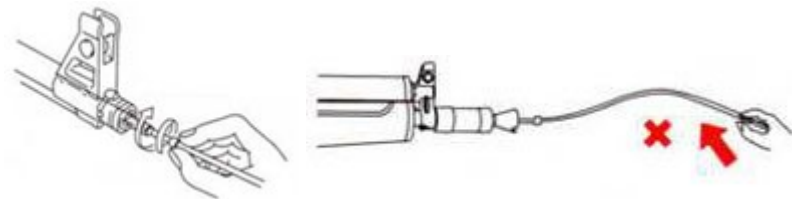

Hold at the leading end of the rod and insert the rod into the barrel while turning the rod.

**Caution:** Inserting the rod will be difficult if you hold rod at the end.



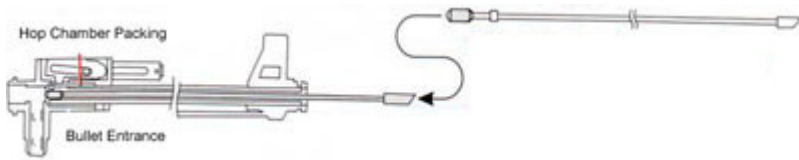

1. Apply a few drops of silicone from the bullet entrance, insert BB bullets into the magazine and fire bullets and fire bullets equivalent to 1 or 2 magazine.
2. To complete the cleaning, Use the cleaning rod (with cotton) as shown, to remove excess oil.

**Caution:** Since the chamber is a precision component, avoid use of used BB bullets.  
 Always carry out maintenance AFTER returning the hop up lever to the Normal position.  
 (Hop-OFF)

[back to top](#)

### Fine Adjustment of Gear Engagement



Remove the screw from the grip bottom.  
 M4 hexagon wrench  
 Insert M4 hexagon wrench into the screw hole adjust  
**Caution:** Only when the motor noise becomes high after operations for a long period of time, conduct the fine adjustment as shown.

**Hold the grip during adjustment. Otherwise, the main body will drop since the grip set screw is removed.**

It is recommended to lock the adjustment screw by a screw locking agent or instantaneous adhesive after adjustment of the motor position is complete.

Normally, do not attempt to adjust.

Be careful not to overly tighten screw as it will damage the gun.

[back to top](#)

### Caution

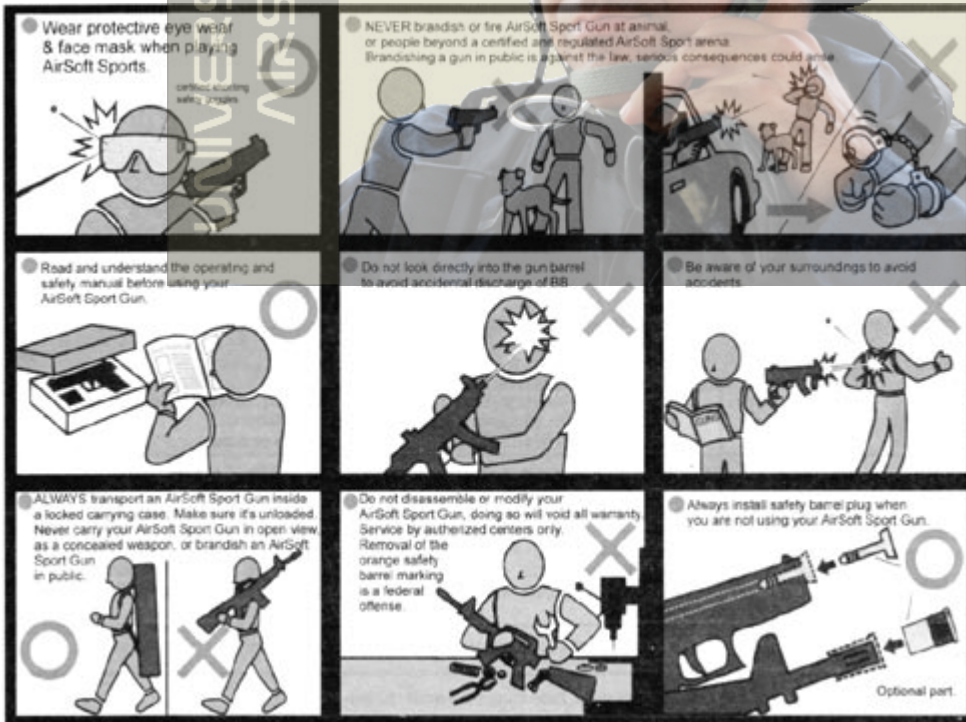

### CAUTION

DISASSEMBLING (TAKING APART) THIS SOFTAIR PRODUCT VOIDS ALL WARRANTY. PRODUCT MUST BE RETURNED IN ITS ORIGINAL PACKAGING. FEDERAL LAW PROHIBITS ALTERING OR REMOVING THE ORANGE MARKING OR PAINTING OVER THE TRANSPARENT PART OF THIS PRODUCT.

Do NOT use 6mm paintballs with this AEG. Shooting paintballs with this unit will result in jamming and will void warranty.

Warning

Sale restricted to ADULTS ONLY, 18 years of age or older.

Proof of age required at the moment of purchase.

When shooting the airsoft gun for target or game, you and all participants must wear goggles or other eye protective gear, also paying attention to ricochers.

Misuse may cause serious injury, especially to the eyes.

The owner / user should adhere to all federal and state laws governing the ownership and use of softair guns.

CONSULT YOUR LOCAL LAW ENFORCEMENT AGENCY PRIOR TO USE.

MISUSE OR UNSAFE USE MAY RESULT IN SEVERE INJURIES OR DEATH.

THIS IS NOT A TOY.

ONLY BY ADULTS OR MINORS UNDER CLOSE ADULT SUPERVISION.

READ THE INSTRUCTION MANUAL CAREFULLY BEFORE USE.

ANY ALTERATION AS TO THE COLORATION AND/OR MAKING OF THIS PRODUCT TO MAKE THIS PRODUCT LOOK MORE LIKE A FIREARM IS DANGEROUS, MAY CAUSE CONFUSION, MAY BE MISTAKEN TO BE A REAL FIREARM BY LAW ENFORCEMENT OFFICERS OR OTHERS AND MAY BE A CRIME.

IT IS DANGEROUS AND MAY BE A CRIME TO BRANDISH OR DISPLAY THIS PRODUCT IN PUBLIC.

PARENTS MUST NOT ALLOW MINORS TO TAKE THIS PRODUCT TO SCHOOL.

HAVING THIS PRODUCT AT SCHOOL MAY BE A CRIME.

[back to top](#)

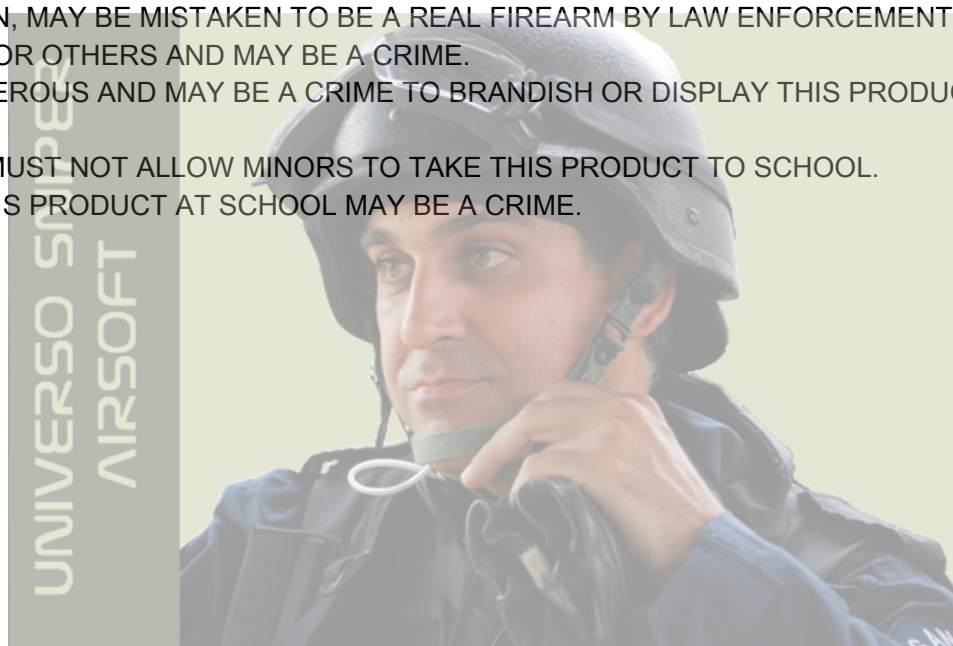

Kraken AK-47 Explosion

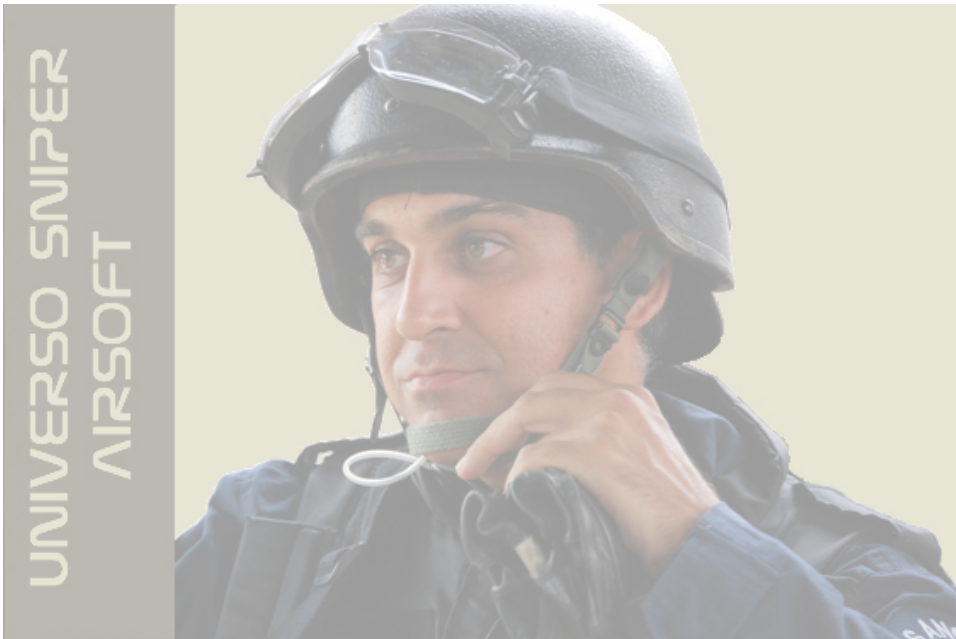

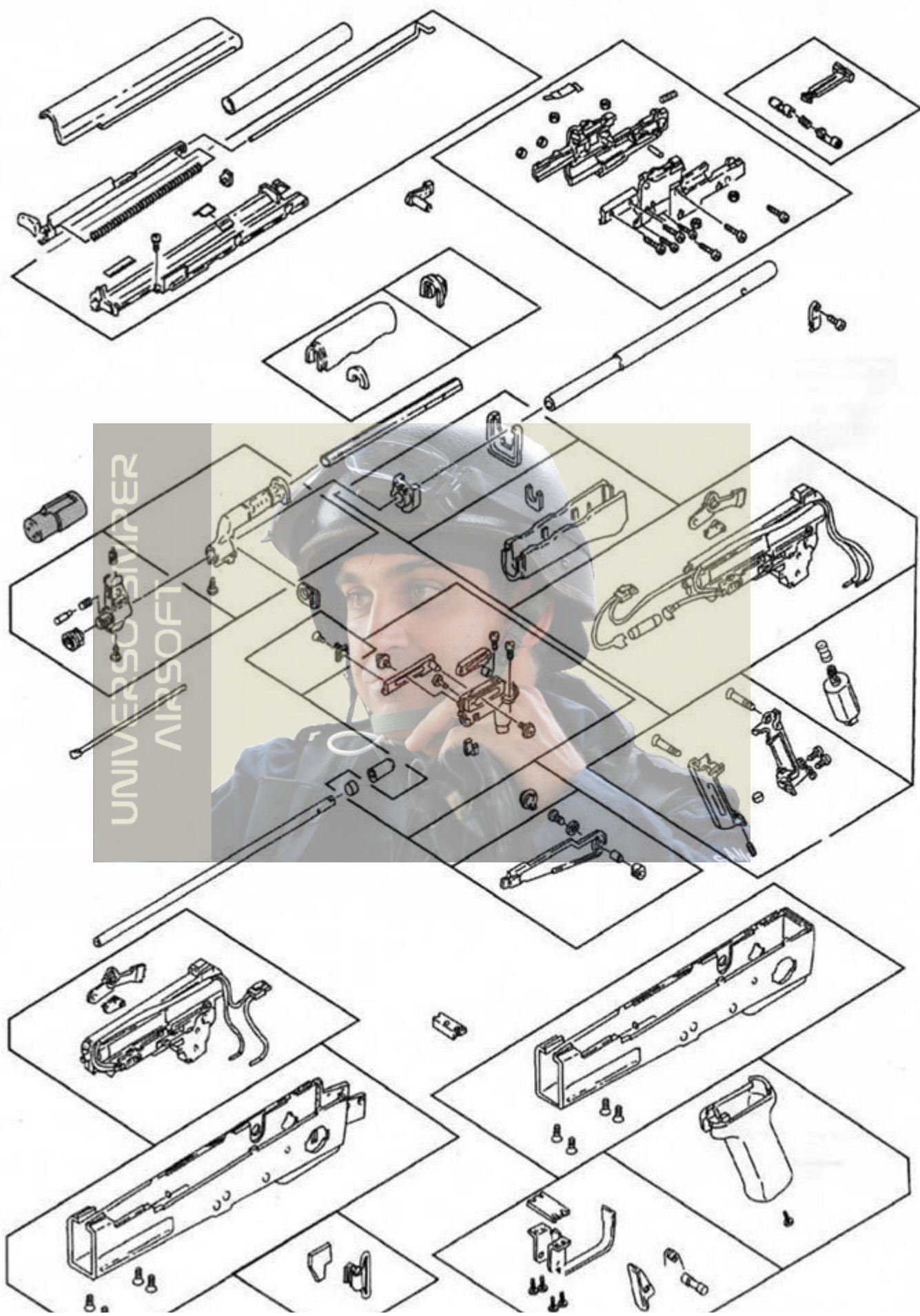

UNIVERSO SIMPER  
AIRSOFT

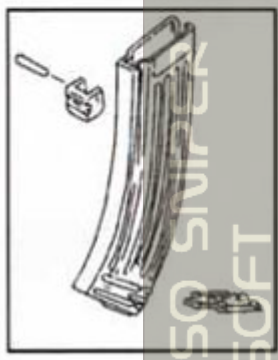
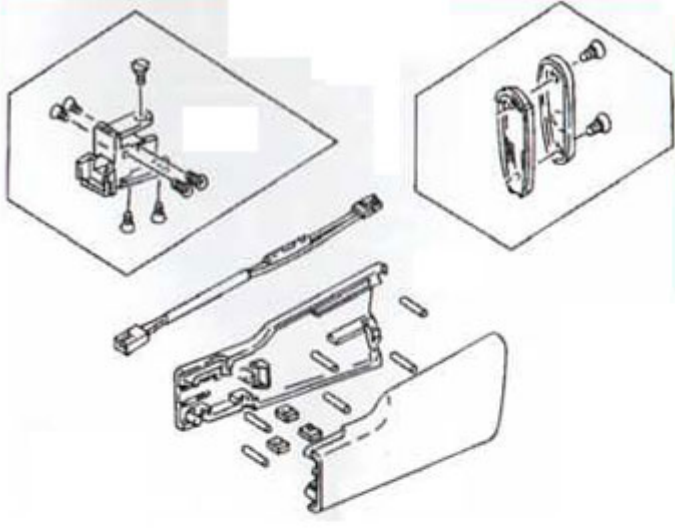

UNIVERSO SNIPER  
AIRSOFT