



CA36

HANDLING CAUTIONS AND INSTRUCTION MANUAL



WARNING

- FOR AGE 18 YEARS OR ABOVE.
- PLEASE READ THE INSTRUCTIONS CAREFULLY BEFORE USAGE. MISUSE OR CARELESS USAGE MAY CAUSE SERIOUS INJURY.
- USER SHOULD OBEY TO ALL LAWS REGARDING THE USAGE AND OWNERSHIP OF AIRSOFT ELECTRIC GUNS.
- FACIAL PROTECTION IS REQUIRED.

Produced By Classic Army, Hong Kong

**HOP-UP
SYSTEM**

1 Outlook / Structure of CA36

Always set the selector switch to the safe position when you are not firing or during storage

CA36

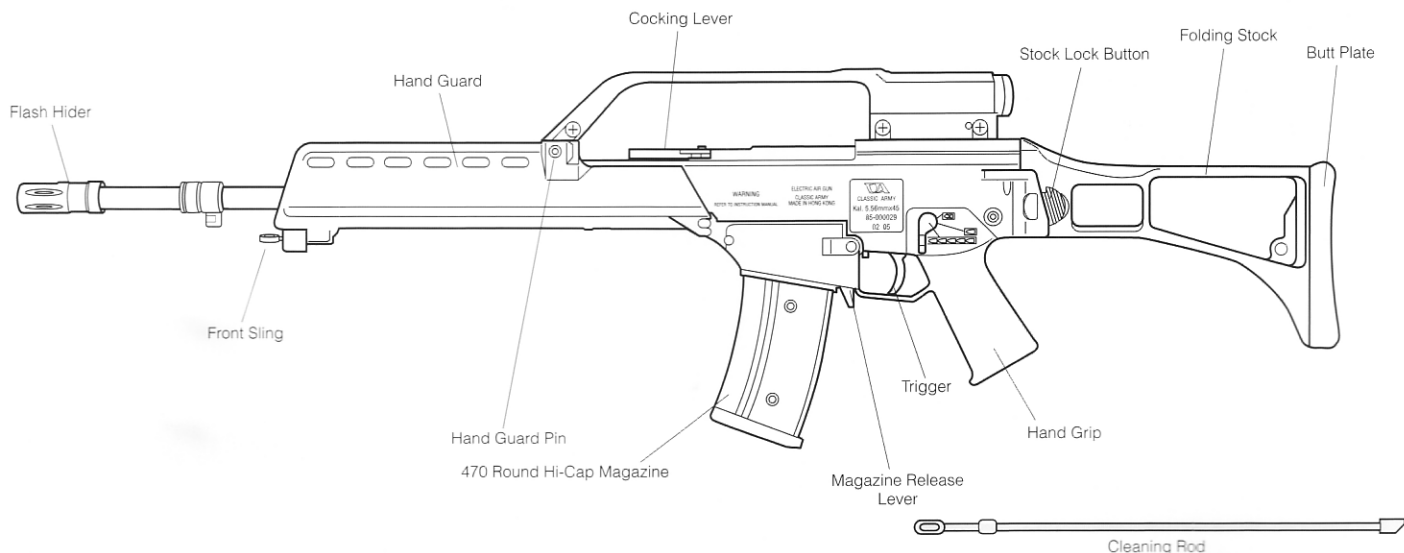

2 Specification

Data of Automatic Electric Gun

Name	CA 36	
Weight	2.79 kg	
Barrel Length	495 mm	
Barrel Caliber	6.08mm	
Pellet Capacity	470	
Pellet	6mm BB	
Initial Pellet Speed	85-95m/s	
Battery Type	Mini Type 8.4V	

3 Operation

1 How to use safety lock

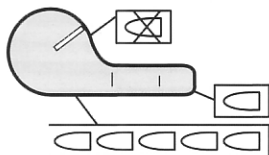

S : Safety Lock

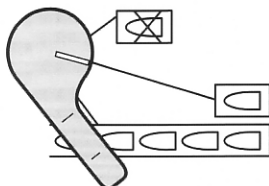

E : Single Lock

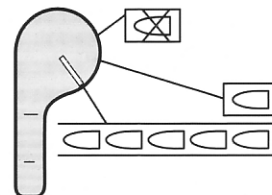

F : Full Auto

2 Magazine Attachment / Detachment Procedure

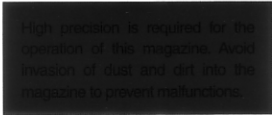

Action against problem
Failure in pellet feeding may occasionally occur during full auto operation. In this case, disconnect the magazine, give a slight shock or poke BB pellets using a stick and then set the magazine again.

CAUTION
About 30 pellets remain in the duct after operation. Be careful with the pellets which will fire out if you hold the gun up-side-down and pull the trigger.



- Occasionally give slight shocks to the gun or shake vertically for ensuring smooth pellet feeding.
- Slightly turn the gear after every 50 to 60 pellets for ensuring smooth pellet feeding.

1 Press the magazine catch to detach the magazine

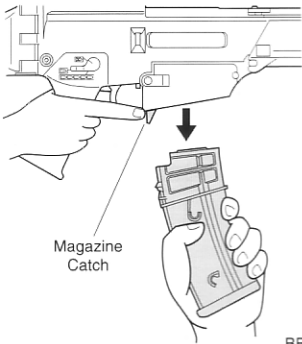

2 Open the top hatch and insert BB pellets. About 470 pellets can be loaded. (Avoid forcing BB pellets into the magazine.)

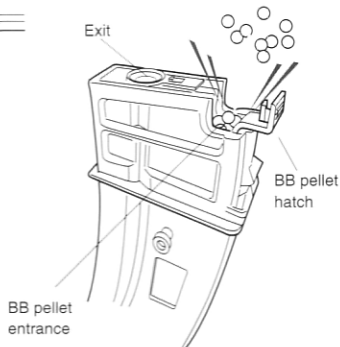

3 Close the hatch

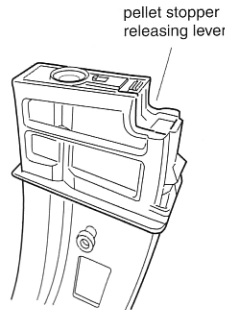

Remove pellets remaining in the duct by reversing the magazine and using the release lever as shown. This ensures smooth operation next time.

4 Hold the magazine with BB pellet entrance facing upward. Turn the gear at the bottom all the way until the click-click sounds change. (If only a small number of BB pellets are inserted, the gear merely makes blank turning.)

Turn the gear all the way until the sound changes.

The gear will not be damaged even if you turn it excessively.

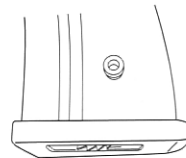

5 Check the BB pellets whether they are lifted up to the exit, and then connect the magazine to the gun.



If pellet feeding is frequently in fault, remove all pellets from the magazine and spray silicone oil for 1 to 2 sec. Note that the hop-up operation may become unstable for a while after using silicone oil.

3 How to insert battery

Set the battery after charging

1 Put the battery in the hand guard and connect the connector

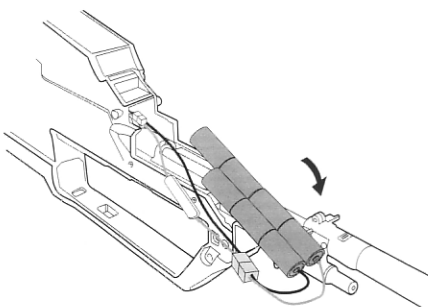

2 Install the connector as shown.

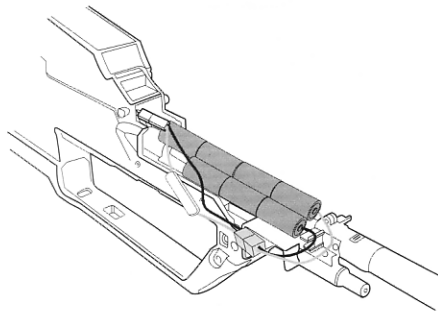

3 Fix the connector in the space underneath the battery.

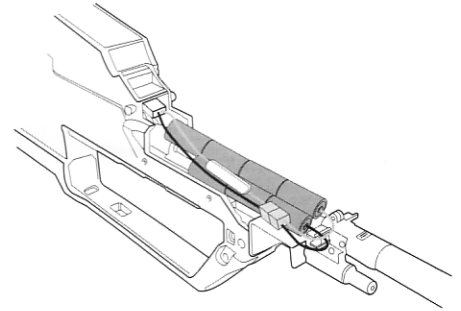

CAUTION • Be careful with your fingers

4 How to adjust the hop up system

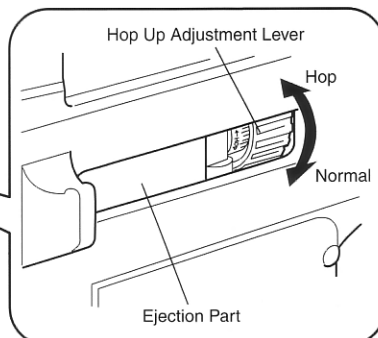
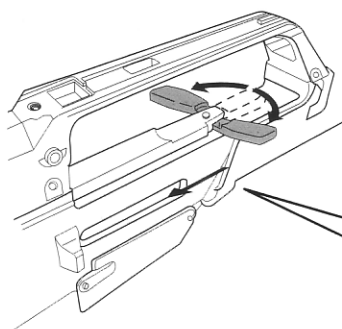

- Keep pulling the cocking lever while adjusting the lever.
- Turn the hop up adjustment lever gradually.
- Turning excessively will adversely affect the trajectory. Stop turning the hop up adjustment lever when pellets fly horizontally.

CAUTION Over turning towards the hop up will cause pellets clogging easily. Keep pulling the trigger with clogged pellets will damage the piston and gears.

5 How to fold the stock

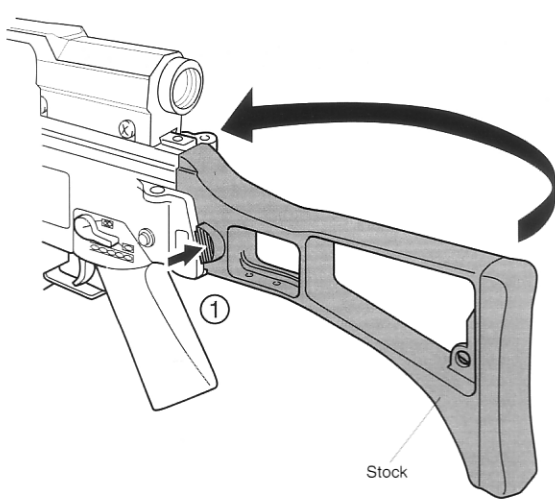

1 Press the stock lock button ①. Fold the stock to the right as shown.

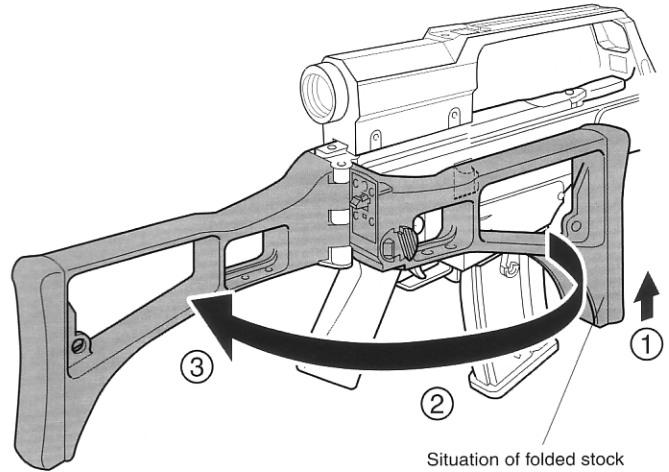

2 Hold the stock a little bit upward. Then, pull the stock back to straight while pushing the stock lock button.

6 How to fire

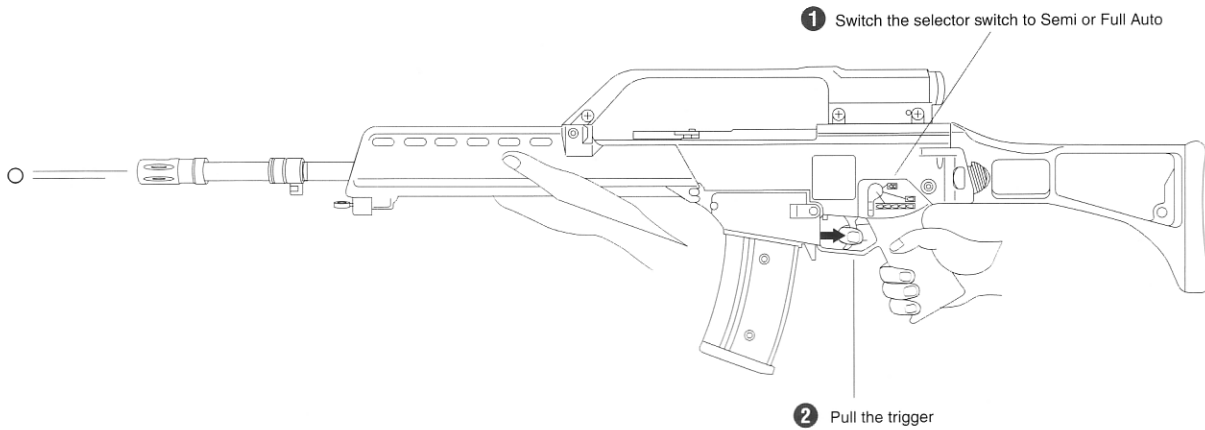

1 Switch the selector switch to Semi or Full Auto

2 Pull the trigger

* Blank firing may occur after setting the magazine, this is the normal operation of the gun.

Cautions on Motor and Battery

- Change the battery if the firing cycle becomes slow.
- Give the air gun a rest for 5 to 10 minutes after firing about 500 pellets, in order to ensure high durability of the motor and battery.

When pellets are clogged

- If pellets are clogged, remove them and apply a few drops of silicone oil into chamber from the magazine entrance as shown or spray silicone oil for 0.5 to 1 sec to obtain smooth continuous firing. (Never use CRC-556 or other mineral oil)



- There are possibilities that no BB comes out after pulling the trigger in the semi auto mode. In that case, do not pull the trigger furiously. Fire 5 to 10 pellets in the full auto mode and then return to the semi auto mode.



- Smell may be generated from the motor for a while when a new air gun is operated. This is the normal operation of the gun.



- The hop up operation may be unstable for 200 to 300 pellets after using silicone oil. This is the normal operation of the gun.

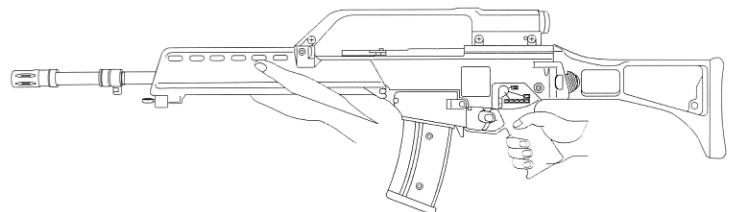
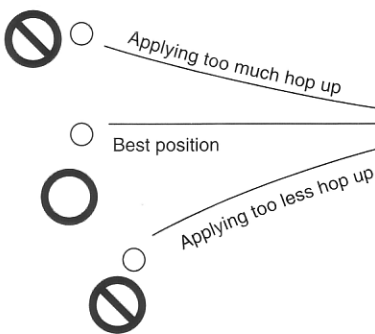

Structural Diagram

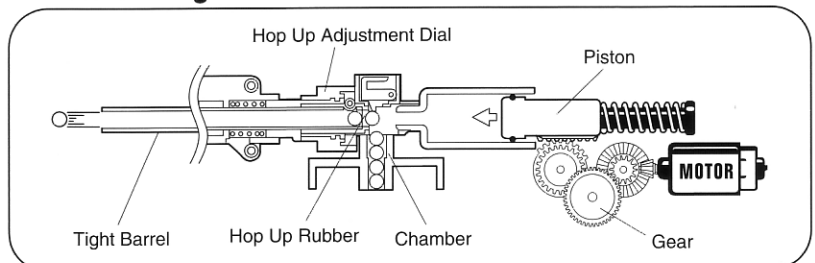

Make sure to return the hop up adjustment dial to NORMAL position when removing clogged pellets.

4 Maintenance

1 How to use a cleaning rod

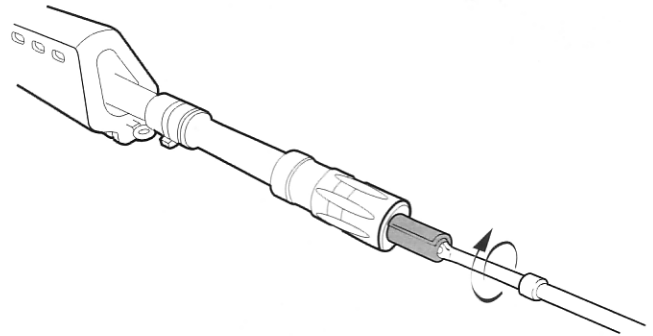
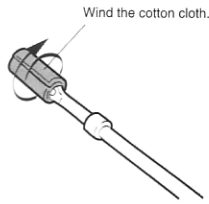
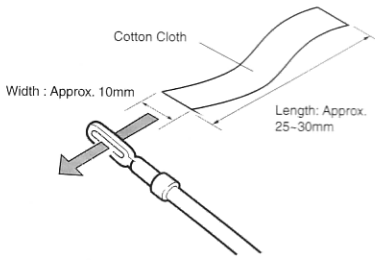

Cut a cotton cloth to the size as shown above and insert one end into the hole in the rod. (Adjust the length of cloth for smooth entry into the barrel.)

Hold the tip of the rod and insert it with turning motion.

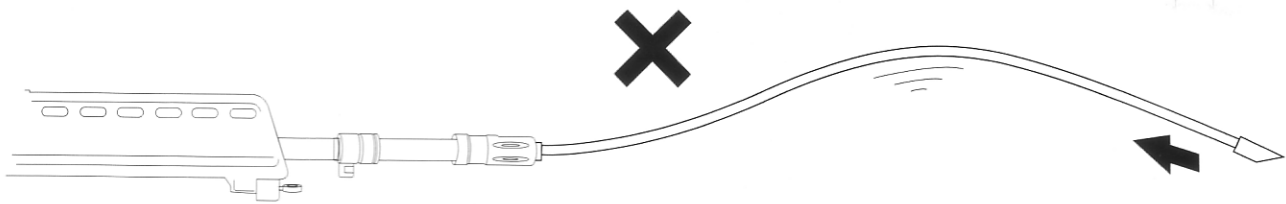

CAUTION: Always begin the maintenance by returning the hop up adjustment lever to NORMAL.



CAUTION: The chamber is a precision component. Never use any used BB pellets.

* The hop-up performance may become unstable for 60 to 70 pellets after maintenance.



Inserting the rod will be difficult if you hold the rod at the end.

- 1 Spray silicone oil for 0.5 to 1 sec in the pellet entrance, then fire 40 to 50 pellets to make the magazine stable.
- 2 Clean the oil from the chamber using the cleaning rod (with cotton) to complete the maintenance.

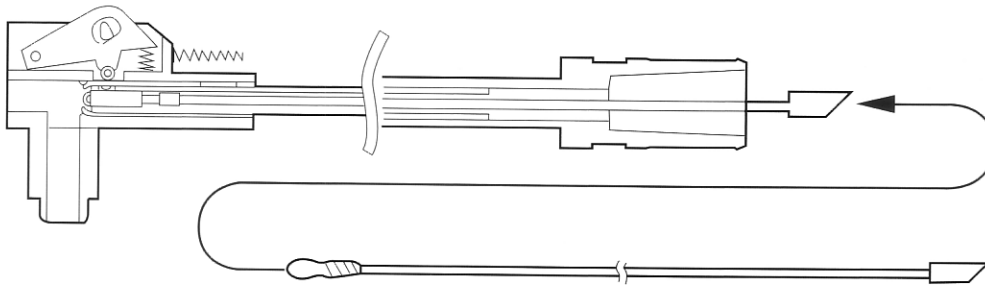

CAUTION: Always begin the maintenance by returning the hop up adjustment lever to Normal.

2 How to replace the fuse

- 1 Open the cover and pull out the fuse box

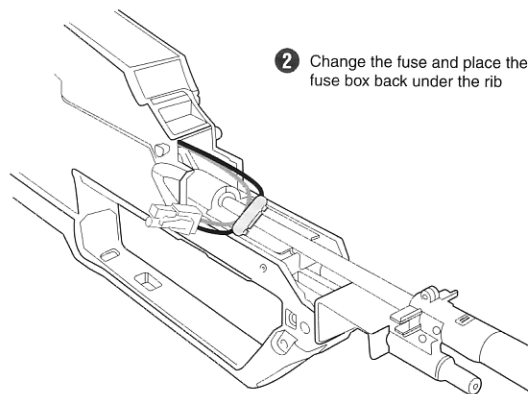

20A Glass Tube Fuse is used



Never use any used BB pellets

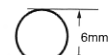

Using new 6mm BB pellet is a must



Please don't use any BB pellet which is not completed.



Please don't use any broken BB pellet.



Please don't use any BB pellet which diameter exceeds 6 mm.

5 WARNING

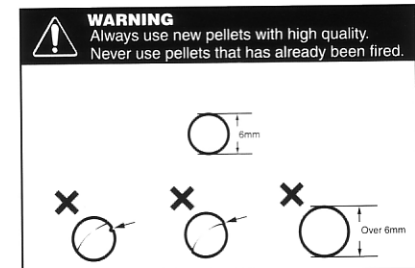
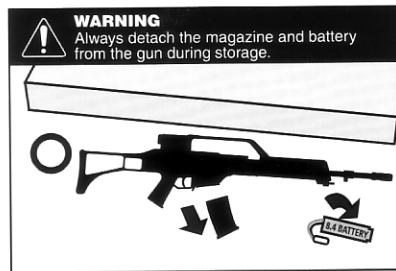
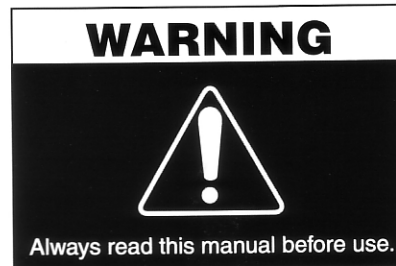
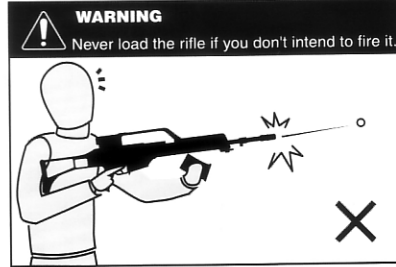

In no event shall Classic Army or any of our partners be liable for any direct or indirect, special, incidental, or consequential damages in connection with the use of our products.

6

For complete product information, dealer locations and technical support, please visit the website of Classic Army Sole Distributors.

Italy, San Marino Republic, Città del Vaticano, Spain (includes Andorra and Gibraltar) Portugal and Switzerland

Co. Name: VI.SE.LE Italiana s.r.l.
 Add.: Via Walter Tobagi n.13, 20090 - Vimodrone (Milan), Italy
 Tel: (39) 02 274 09455
 Fax: (39) 02 274 09455
 Email: visele@classicarmyitalia.com
 Website: <http://www.classicarmyitalia.com/>

Denmark, Sweden, Norway & Finland, France, Germany, Austria, United Kingdom, Poland, Baltic countries, Belgium, Luxembourg, the Czech Republic and Slovakia

Co. Name: ActionSportGames A/S
 Add.: No.: Bakkegaardsvej 304, DK-3050 Humlebaek, Denmark
 Tel: (45) 89 28 18 88
 Fax: (45) 49 19 31 60
 Email: sales@softgun.dk
 Website: <http://www.actionsportgames.com/>

The United States of America

Co. Name: Spartan Imports, Inc.
 Email: info@spartanimports.com
 Website: <http://www.spartanimports.com/>

Taiwan

Co. Name: F-Link Int'l Enterprise Co. Ltd.
 Add.: No. 283, Jo Through 2nd Road, Sun Min Dist, Kaohsiung, Taiwan, R.O.C.
 Tel: (886) 7 323 0988
 Fax: (886) 7 323 4055
 Email: kssa.kssa@msa.hinet.net
 Website: <http://www.soloman.com.tw/>

7 Exploded Diagram

