



HANDLING CAUTIONS AND INSTRUCTION MANUAL

*Airsoft Electric Gun
Metal Casting*

M0144
MATCH / SCOUT
S003M **S004M**

WARNING

- FOR AGE 18 OR ABOVE.
- PLEASE READ THE INSTRUCTIONS CAREFULLY BEFORE USE.
MISUSE OR CARELESS USE MAY CAUSE SERIOUS INJURY.
- USER SHOULD OBEY TO THE LAWS REGARDING THE USAGE AND OWNERSHIP
OF AIRSOFT ELECTRIC GUNS.
- FACIAL PROTECTION IS REQUIRED.



Produced By Classic Army, Hong Kong

1 Outlook / Structure

Always set the selector switch to the safe position when you are not firing or during storage

M14 Match

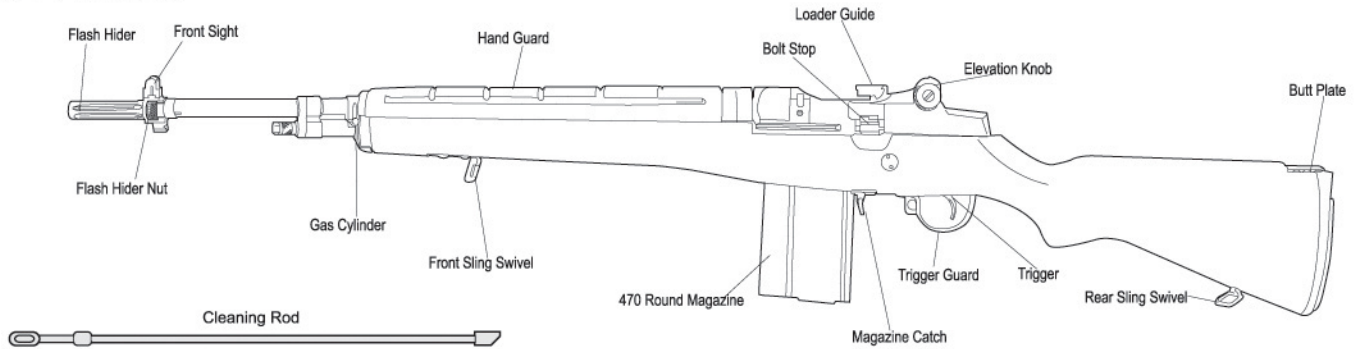

M14 Scout

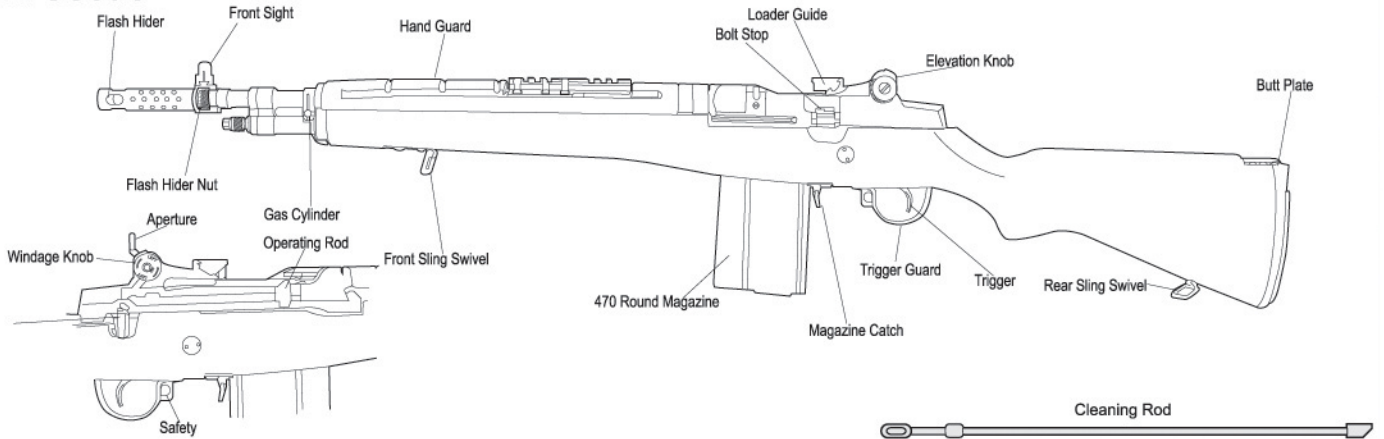

2 Specification

Data of Automatic Electric Gun

Name	M14 Match	M14 Scout
Weight	3.90kg	3.90kg
Barrel Length	510mm	463mm
Barrel Caliber	6.08mm	6.08mm
Pellet Capacity	470	470
Pellet	6mm BB	6mm BB
Initial Pellet Speed	85-105 m/s	85-105 m/s
Battery Type	Large Type (8.4v)	Large Type (8.4v)

3 Operation

1 How to use safety lock

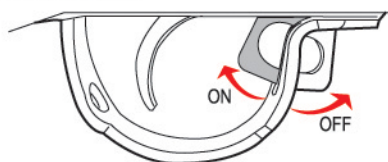

Safety Lock



Semi Auto

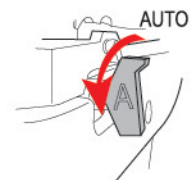

Full Auto

2 How to insert battery

1 Open the butt plate and battery cover

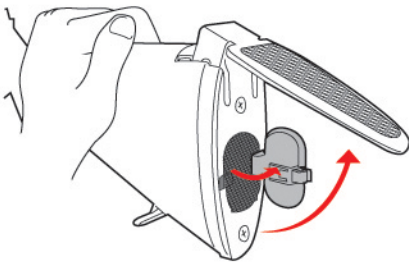

2 Pull out the connector

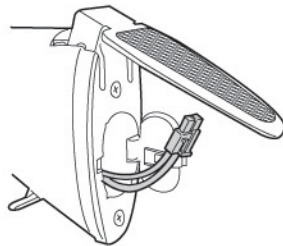

3 Insert the battery into the stock and connect the connectors

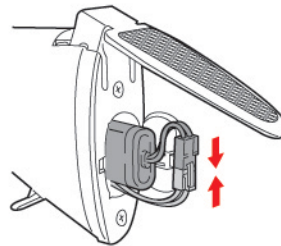

4 Close the cover and butt plate

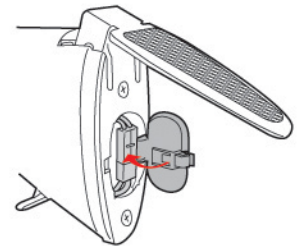

CAUTION Be careful with your fingers.

Set the battery after charging

3 Magazine Attachment / Detachment Procedure

High precision is required for the operation of this magazine. Avoid invasion of dust and dirt into the magazine to prevent malfunctions.

Action against problem

Failure in pellet feeding may occasionally occur during full auto operation. In this case, disconnect the magazine, give a slight shock or poke BB pellets using a stick and then set the magazine again.

CAUTION

About 30 pellets will remain in the duct after operation. Be careful of any pellets firing out if you hold the gun up-side-down and pull the trigger.

Ensure smooth pellet feeding

- Occasionally give slight shocks to the gun or shake vertically for ensuring smooth pellet feeding.
- Slightly turn the gear after every 50 to 60 pellets to ensure smooth pellet feeding.

1. Press the magazine catch to detach the magazine

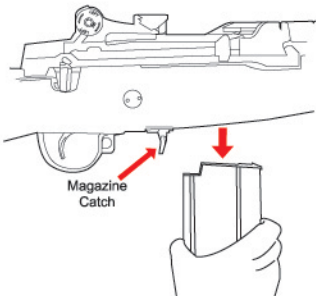

2. Open the top hatch and insert BB pellets. About 190 pellets can be loaded. (Avoid forcing BB pellets into the magazine.)

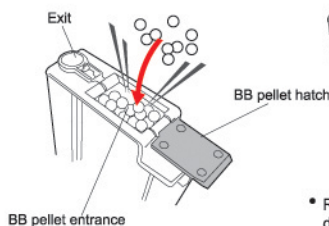

3. Close the hatch

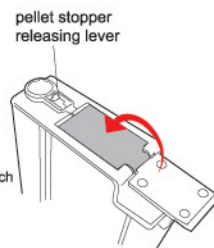

4. Hold the Magazine with BB pellet entrance facing upward. Turn the gear at the bottom all the way until the click-click sounds change. (If only a small number of BB pellets are inserted, the gear merely makes blank turning.)

Turn the gear all the way until the sound changes.

The gear will not be damaged even if you turn it excessively.

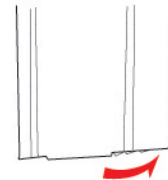

5. Check the BB pellets whether they are lifted up to the exit, and then connect the



If pellet feeding is frequently in fault, remove all pellets from the magazine and spraysilicone oil for 1 to 2 sec. Note that the hop-up operation may become unstable for a while after using silicone oil.

Remove pellets remaining in the duct by reversing the magazine and using the releasing lever as shown. This ensures smooth operation next time.

4 How to fire

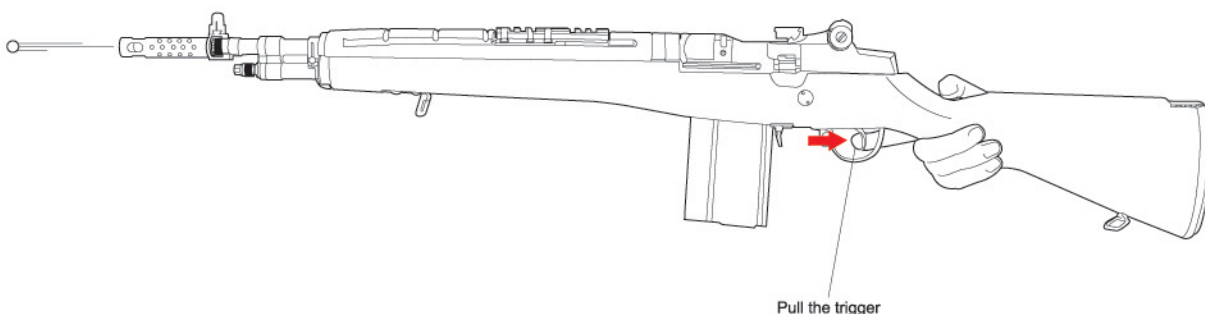

CAUTION

- There are possible cases that no firing occurs after pulling the trigger in the semi auto mode. In case, do not pull the trigger furiously. Fire 5 to 10 pellets in the full auto mode and then return to the semi auto mode.

CAUTION

- Smell may be generated from the motor for a while when a new air gun is operated, this is the normal operation of the gun.

CAUTION

- The hop up operation may be unstable for 200 to 300 pellets after using silicone oil, this is the normal operation of the gun.

* Blank firing may occur after setting the magazine, this is the normal operation of the gun.

Cautions on Motor and Battery

- Change the battery if the firing cycle becomes slow.
- Give the air gun a rest for 5 to 10 minutes after firing about 500 pellets in order to ensure high durability of the motor and battery.

When pellets are clogged

- Remove them and apply a few drops of silicone oil into chamber from the magazine entrance as shown or spray silicone oil for 0.5 to 1 sec, to obtain smooth continuous firing. (Never use CRC-556 or other mineral oil)

5 How to adjust the hop-up

1 Open the ejection port cover

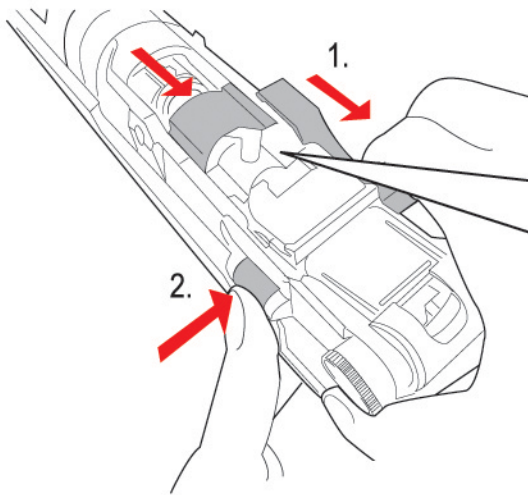

2 Adjust the Hop-up chamber

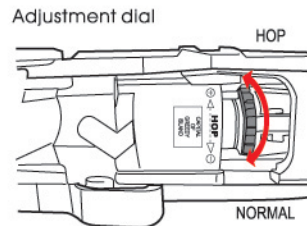

Ensure that the adjustment dial is never contaminated by dust and dirt.

- 1 Keep pulling the cocking lever while adjusting the dial
- 2 Turn the hop up adjustment dial gradually
- 3 Turning excessively will adversely affect the trajectory. Stop turning the hop up adjustment lever when pellets shoot horizontally

CAUTION Over turning towards the hop up will cause pellets clogging easily. Keep pulling the trigger with clogged pellets will damage the piston and gears.

CAUTION Be careful with your fingers.

6 Rear Sight Adjustment

1 Rear Sight: For precision targeting

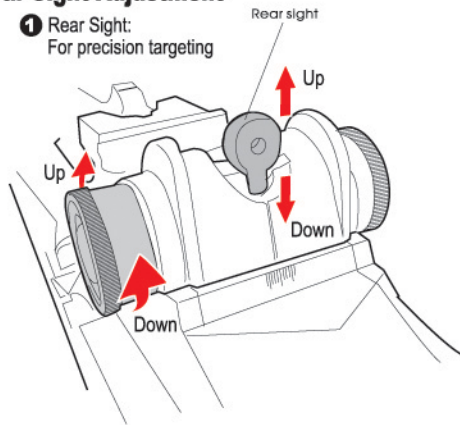

2 Rear Sight: For left or right adjustment

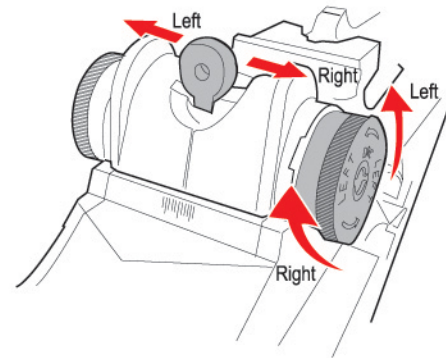

4 Proper Disassembling

1 Take off the gas cylinder

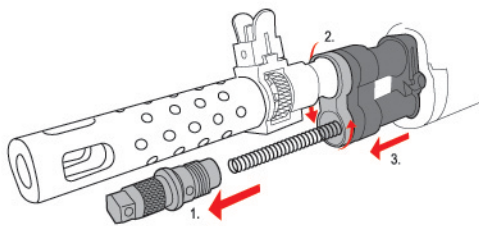

2 Pull down the trigger guard completely

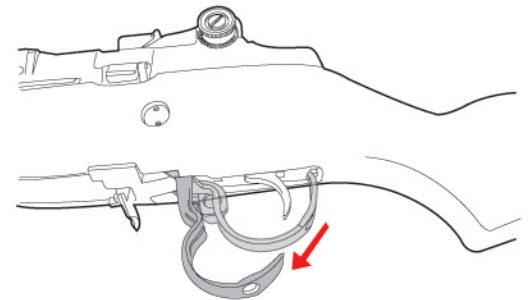

3 Take off the trigger guard set carefully

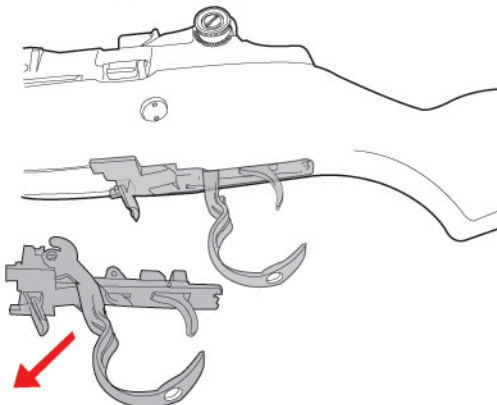

4 Disassembling the upper part forward & upward from the stock

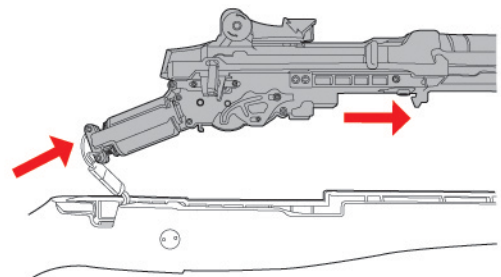

5 Maintenance

1 How to use a cleaning rod

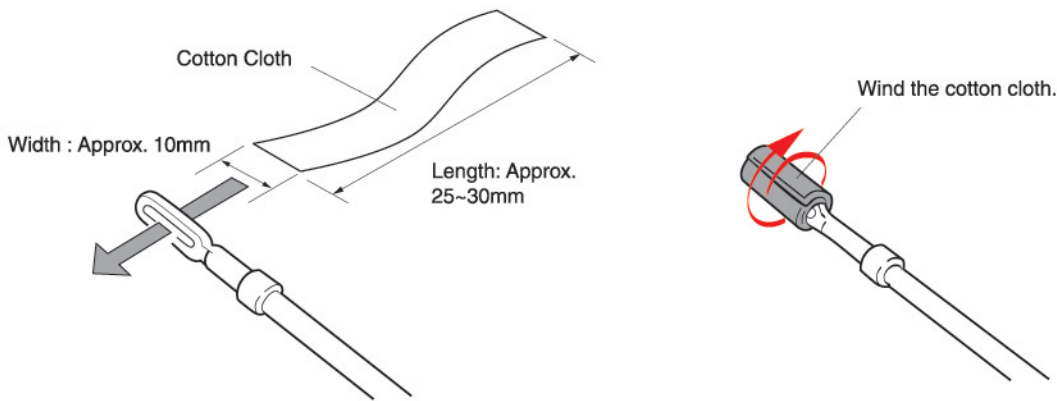

CAUTION Never use any used BB pellets

Use new 6mm BB pellet is a must

Please don't use any BB pellet which is not completed.

Please don't use any broken BB pellet.

Please don't use any BB pellet which diameter exceeded 6 mm.

Cut a cotton cloth to the size as shown above and insert one end into the hole in the rod.
(Adjust the length of cloth for smooth entry into the barrel.)



CAUTION: Always begin the maintenance by returning the hop up adjustment lever to **NORMAL**

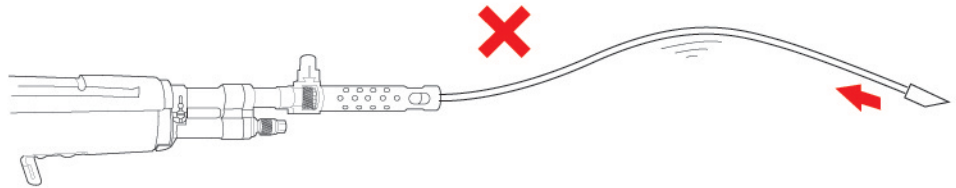

CAUTION: The chamber is a precision component.
Never use any used BB pellets.

* The hop-up performance may become unstable for 60 to 70 pellets after maintenance.



Inserting the rod will be difficult if you hold the rod at the end.

- 1 Spray silicone oil for 0.5 to 1 sec in the pellet entrance, then fire 40 to 50 pellets to make the magazine stable.
- 2 Clean the oil from the chamber using the cleaning rod (with cotton) to complete the maintenance.

2 How to replace the fuse

1. Open the cover and pull out the fuse box

2. Change the fuse and place the fuse box back under the rib

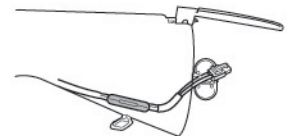
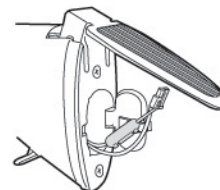
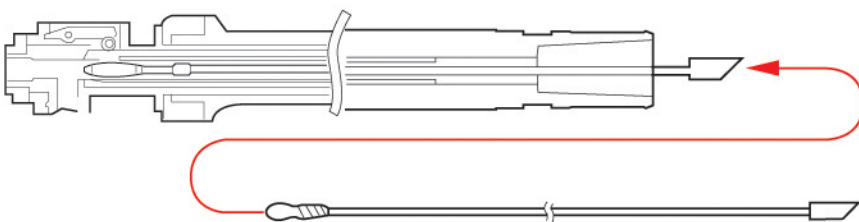

CAUTION: Always begin the maintenance by returning the hop up adjustment lever to Normal.

20A Glass Tube Fuse is used

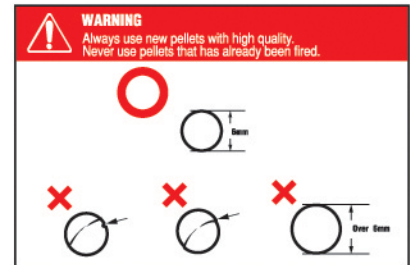
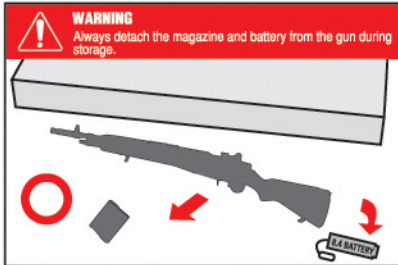

6 ! WARNING

In no event shall Classic Army or any of our partners be liable for any direct or indirect, special, incidental, or consequential damages in connection with the use of our products.

7 For complete product information, dealer locations and technical support, please visit the website of Classic Army Sole Distributors .
Denmark, Sweden, Norway & Finland, France, Germany, Austria, United Kingdom, Poland, Baltic countries, Belgium, Luxembourg, the Czech Republic and Slovakia

Co. Name: ActionSportGames A/S
 Add.: Bakkegaardsvej 304, DK-3050 Humlebaek, Denmark
 Tel: (45) 89 28 18 88
 Fax: (45) 49 19 31 60
 Email: sales@actionsportgames.com
 Website: <http://www.actionsportgames.com/>

Italy, San Marino Republic, Città del Vaticano, Spain (includes Andorra and Gibraltar) Portugal and Switzerland

Co. Name: VI.SE.IE Italiana S.r.l.
 Add.: Via Treves n.17, 20090 Vimodrone, MI Italy
 Tel: (+39)02 25459610
 Fax: (+39)02 25118560
 Email: visele@classicarmyitalia.com
 Website: <http://www.classicarmyitalia.com/>

The United States of America

Co. Name: Spartan Imports, Inc.
 Add.: 213 Lawrence Avenue, S. San Francisco, California, USA 94080
 Tel: (1) 650 589 5501
 Fax: (1) 650 589 5552
 Email: info@spartanimports.com
 Website: <http://www.spartanimports.com/>

Taiwan

Co. Name: F-Link Int'l Enterprise Co. Ltd.
 Add.: 3 Lane 62, Jianguo 1st Rd., Lingya District, Kaohsiung City 802, Taiwan, R.O.C.
 Tel : (886) 7-710 0198
 Fax : (886) 7-710 0398
 Email: kssa.kssa@msa.hinet.net
 Website: <http://www.soloman.com.tw/>

PDF por Sniper
 Matadores Airsoft Club
www.matadoresairsoft.com

Russian Federation and Belorussia

Co. Name: Uragan Limited.
 Add.: Novorogozhskaya str. 12/3 Moscow 107954 Russia
 Tel : (7) 495 323 5366
 Fax : (7) 495 323 5366
 Email: toybike@yandex.ru
 Website: <http://www.classicarmy.ru/>

