



SA58 CARBINE

HANDLING CAUTIONS AND INSTRUCTION MANUAL



CA027M

WARNING

- FOR AGE 18 OR ABOVE.
- PLEASE READ THE INSTRUCTIONS CAREFULLY BEFORE USE. MISUSE OR CARELESS USE MAY CAUSE SERIOUS INJURY.
- USER SHOULD OBEY TO THE LAWS REGARDING THE USAGE AND OWNERSHIP OF AIRSOFT ELECTRIC GUNS.
- FACIAL PROTECTION IS REQUIRED.

**HOP-UP
SYSTEM**

Produced By Classic Army, Hong Kong

1 Outlook / Structure of SA58 Carbine

Always set the selector switch to the safe position when you are not firing or during storage

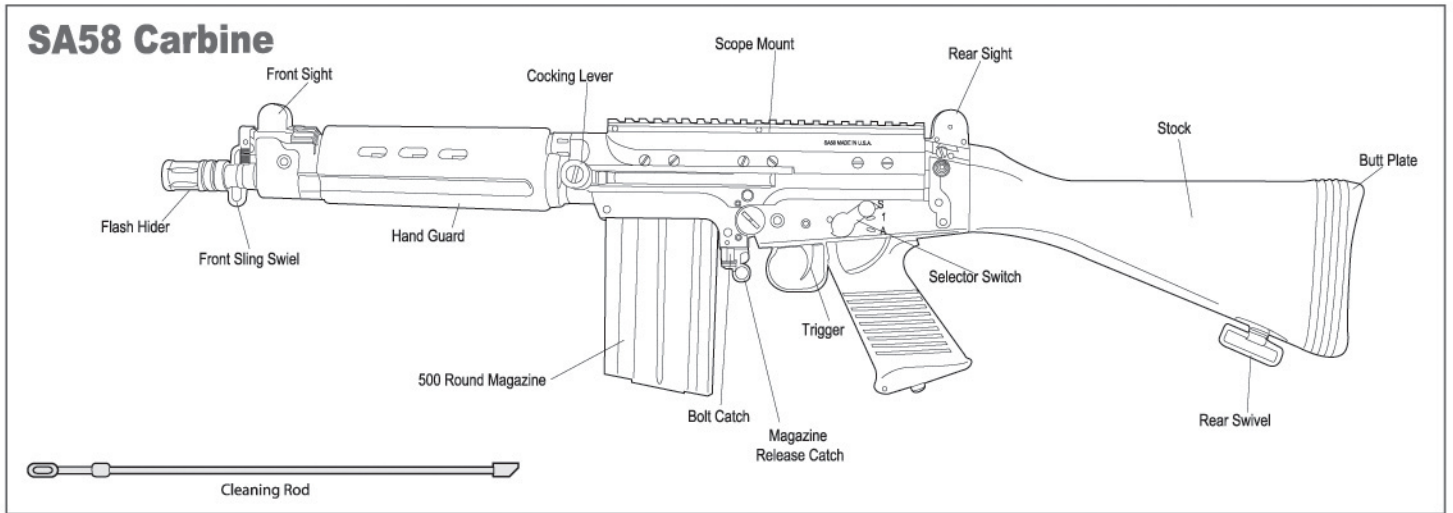

2 Specification

Data of Automatic Electric Gun	
Name	SA58 Carbine 
Weight	2.876kg
Barrel Length	335mm
Barrel Caliber	6.08mm
Pellet Capacity	500
Pellet	6mm BB
Initial Pellet Speed	85-105m/sec
Battery Type	Large Type (8.4V)

3 Operation

1 How to use safety lock

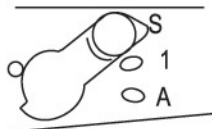

S : Safety Lock



E : Semi Auto



F : Full Auto

2 Magazine Attachment / Detachment procedure

High precision is required for the operation of this magazine. Avoid invasion by dust and dirt into the magazine to prevent malfunctions.

Action against problem
Failure in pellet feeding may occasionally occur during full auto operation. In this case, disconnect the magazine, give a slight shock or poke BB pellets using a stick and then set the magazine again.



About 30 pellets remain in the duct after operation. Be careful with the pellets which will fire out if you hold the gun up-side-down and pull the trigger.

Ensure Smooth Pellet Feeding

- Occasionally give slight shocks to the gun or shake vertically for ensuring smooth pellet feeding.
- Slightly turn the gear after every 50 to 60 pellets for ensuring smooth pellet feeding.

- 1** Press the magazine catch to detach the magazine
- 2** Open the top hatch and insert BB pellets. About 330 pellets can be loaded. (Avoid forcing BB pellets into the magazine.)

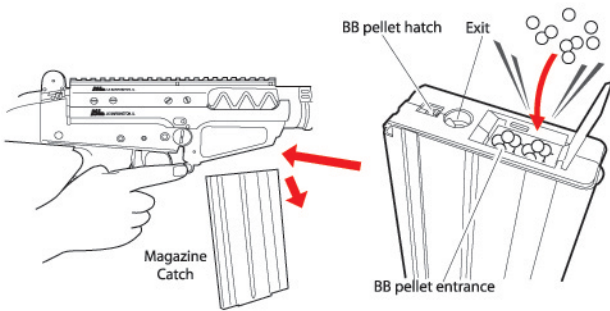

- 3** Close the hatch
- 4** Hold the Magazine with BB pellet entrance facing upward. Turn the gear at the bottom all the way until the click-click sounds change. (If only a small number of BB pellets are inserted, the gear merely makes blank turning.)
- 5** Check the BB pellets whether they are lifted up to the exit, and then connect then magazine to the gun.

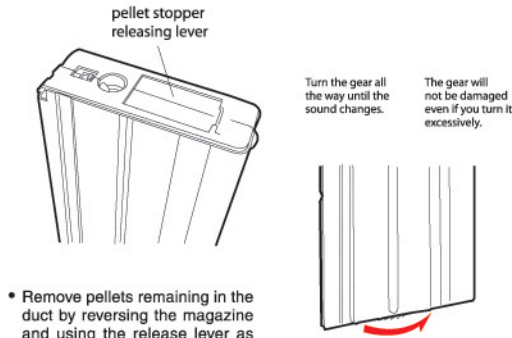

• Remove pellets remaining in the duct by reversing the magazine and using the release lever as shown. This ensures smooth operation next time.

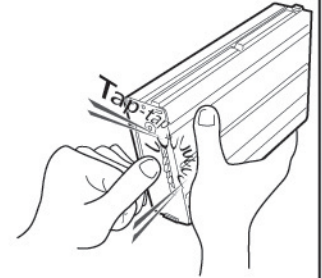

If pellet feeding is frequently in fault, remove all pellets from the magazine and spraysilicone oil for 1 to 2 sec. Note that the hop-up operation may become unstable for a while after using silicone oil.

3 How to insert battery

- 1** Lower the butt plate and open

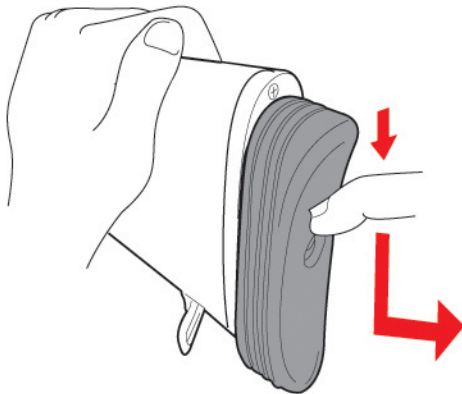

Set the battery after charging

- 2** Pull out the connector

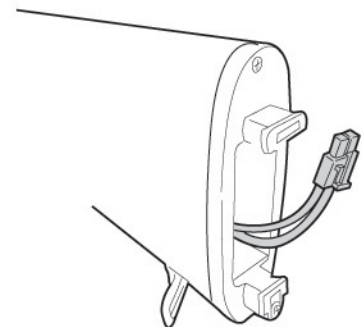

- 3** Insert the battery into the stock and connect the connectors

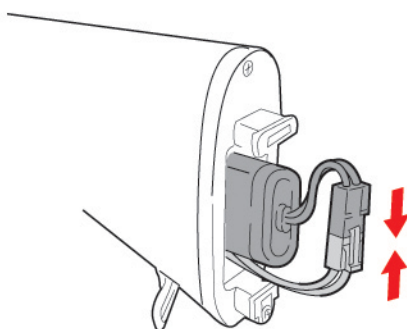

- 4** Close the butt plate

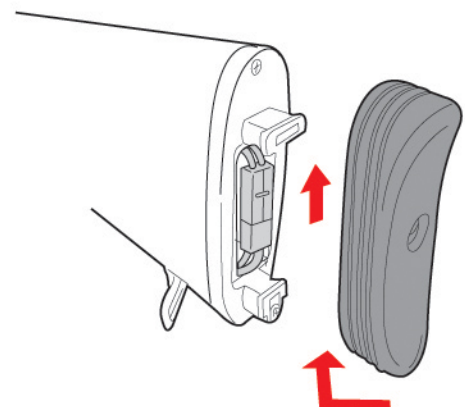

• Be careful with your fingers

4 How to fire

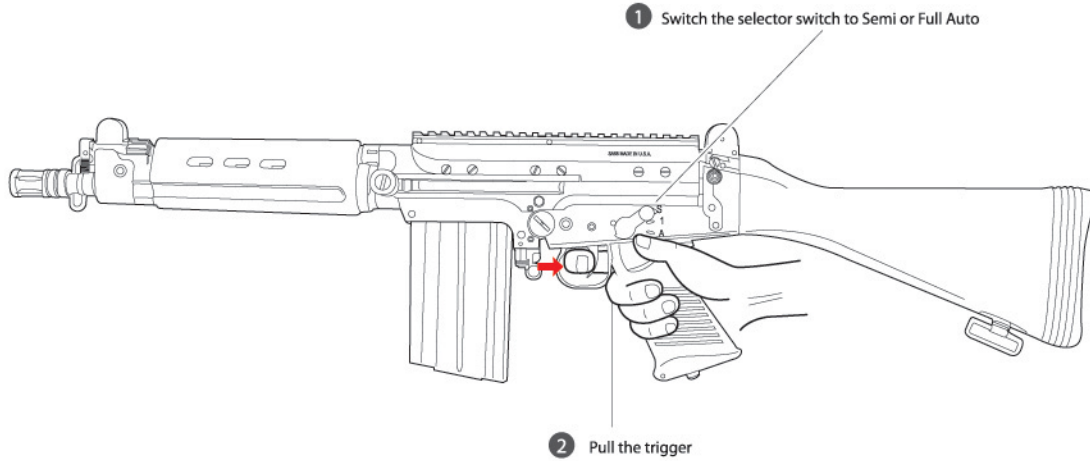

1 Switch the selector switch to Semi or Full Auto

2 Pull the trigger



• There are possible cases that no firing occurs after pulling the trigger in the semi auto mode. In case, do not pull the trigger furiously. Fire 5 to 10 pellets in the full auto mode and then return to the semi auto mode.



• Smell may be generated from the motor for a while when a new air gun is operated, this is the normal operation of the gun.



• The hop up operation may be unstable for 200 to 300 pellets after using silicone oil, this is the normal operation of the gun.

* A blank firing may occur at triggering after setting the magazine, this is the normal operation of the gun.

Cautions on Motor and Battery

- Change the battery if the firing cycle becomes slow.
- Give the air gun a rest for 5 to 10 minutes after firing about 500 pellets, in order to ensure high durability of the motor and battery.

When pellets are clogged

- If pellets are clogged, remove them and apply a few drops of silicone oil into chamber from the magazine entrance as shown or spray silicone oil for 0.5 to 1 sec to obtain smooth continuous firing. (Never use CRC-556 or other mineral oil)

5 How to adjust the hop up system

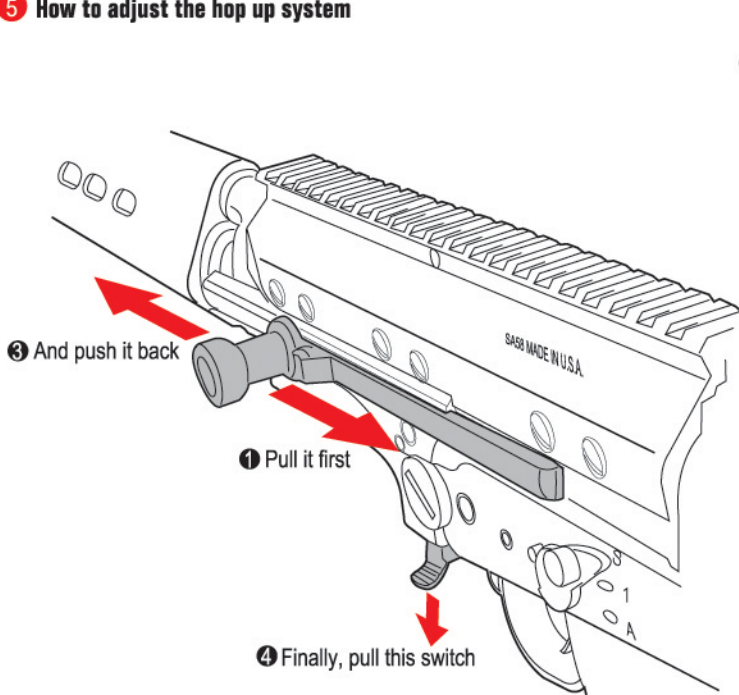

1 Pull it first

3 And push it back

4 Finally, pull this switch

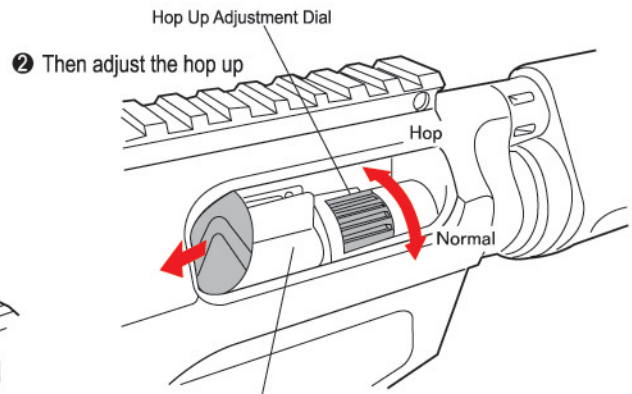

2 Then adjust the hop up

Ejection Part

- 1 Keep pulling the cocking lever while adjusting the dial
- 2 Turn the hop up adjustment dial gradually
- 3 Turning excessively will adversely affect the trajectory. Stop turning the hop up adjustment lever when pellets shoot horizontally



Over turning towards the hop up will cause pellets clogging easily. Keep pulling the trigger with clogged pellets will damage the piston and gears.



Be careful with your fingers.

6 Rear Sight Adjustment

1 Adjust the sight forward and backward

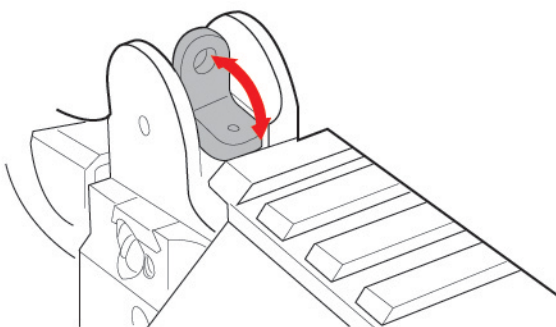

2 Turning clockwise:
Raise the hitting point

Counterclockwise:
Lower the hitting point

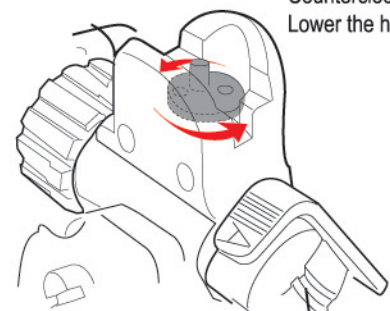

4 Maintenance

1 How to use a cleaning rod

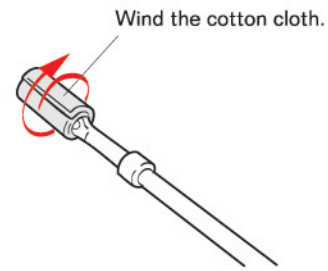
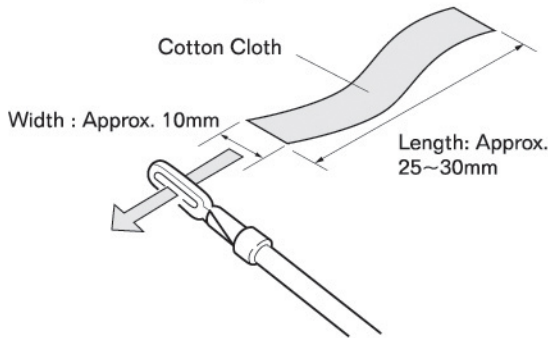

Cut a cotton cloth to the size shown above and insert one end into the hole in the rod.
(Adjust the length of cloth for smooth entry into the barrel.)



CAUTION: Always begin the maintenance by returning the Hop Up adjustment lever to NORMAL.

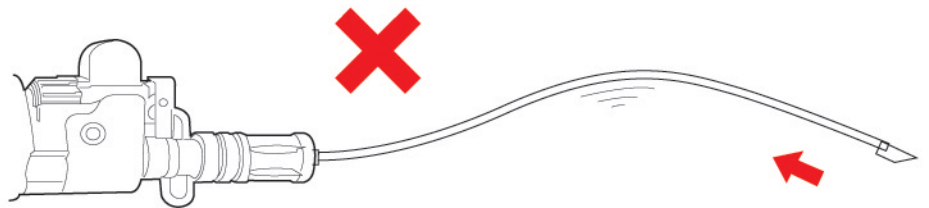

CAUTION: The chamber is a precision component. Never use any used BB pellets.



Inserting the rod will be difficult if you hold the rod at the end.

* The hop-up performance may become unstable for 60 to 70 pellets after maintenance.

- 1 Spray silicone oil for 0.5 to 1 sec in the pellet entrance, then fire 40 or 50 pellets to make the magazine more stable.
- 2 Clean up the oil from the chamber by using the cleaning rod (with cotton) to complete the maintenance.



CAUTION: Always begin the maintenance by returning the Hop Up adjustment lever to Normal.

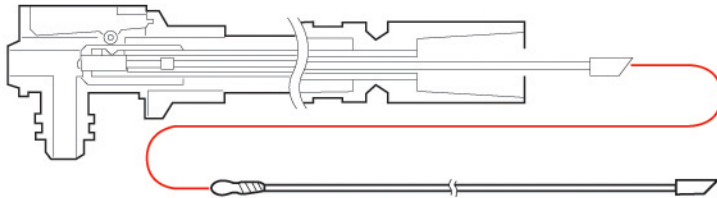

20A Glass Tube Fuse is used



Never use any used BB pellets



Using new 6mm BB pellet is a must



Please don't use the BB pellet which is not completed.



Please don't use the broken BB pellet.

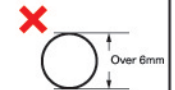

Please don't use the BB pellet which diameter is exceeded 6 mm.

5 Proper Disassembling

1 Release the screw in counterclockwise

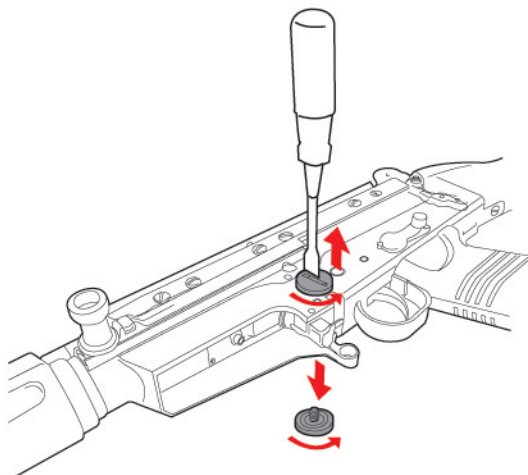

2 Pull the upper receiver forward and backward

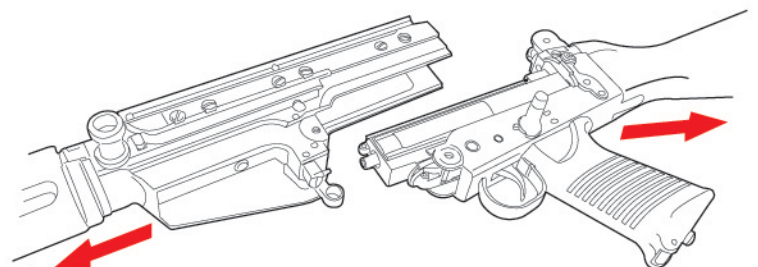

6  **WARNING**

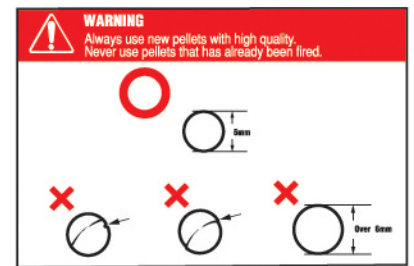
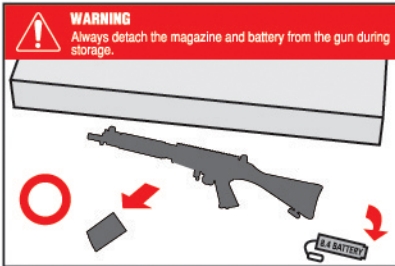

In no event shall Classic Army or any of our partners be liable for any direct or indirect, special, incidental, or consequential damages in connection with the use of our products.

7 For complete product information, dealer locations and technical support, please visit the website of Classic Army Sole Distributors .

Denmark, Sweden, Norway & Finland, France, Germany, Austria, United Kingdom, Poland, Baltic countries, Belgium, Luxembourg, the Czech Republic and Slovakia

Co. Name: ActionSportGames A/S
 Add.: Bakkegaardsvej 304, DK-3050 Humlebaek, Denmark
 Tel: (45) 89 28 18 88
 Fax: (45) 49 19 31 60
 Email: sales@actionportgames.com
 Website: http://www.actionportgames.com/

Italy, San Marino Republic, Città del Vaticano, Spain (includes Andorra and Gibraltar) Portugal and Switzerland

Co. Name: VI.SE.LE Italiana S.r.l.
 Add.: Via Treves n.17, 20090 Vimodrone, MI Italy
 Tel: (+39)02 25459610
 Fax: (+39)02 25118560
 Email: visele@classicarmyitalia.com
 Website: http://www.classicarmyitalia.com/

The United States of America

Co. Name: Spartan Imports, Inc.
 Add.: 213 Lawrence Avenue, S. San Francisco, California, USA 94080
 Tel: (1) 650 589 5501
 Fax: (1) 650 589 5552
 Email: info@spartanimports.com
 Website: http://www.spartanimports.com/

Taiwan

Co. Name: F-Link Int'l Enterprise Co. Ltd.
 Add.: 3 Lane 62, Jianguo 1st Rd., Lingya District, Kaohsiung City 802, Taiwan, R.O.C.
 Tel : (886) 7-710 0198
 Fax : (886) 7-710 0398
 Email: kssa.kssa@msa.hinet.net
 Website: http://www.soloman.com.tw/

Russian Federation and Belorussia

Co. Name: Uragan Limited.
 Add.: Novorogozhskaya str. 12/3 Moscow 107954 Russia
 Tel : (7) 495 323 5366
 Fax : (7) 495 323 5366
 Email: toybike@yandex.ru
 Website: http://www.classicarmy.ru/

8 Exploded Diagram

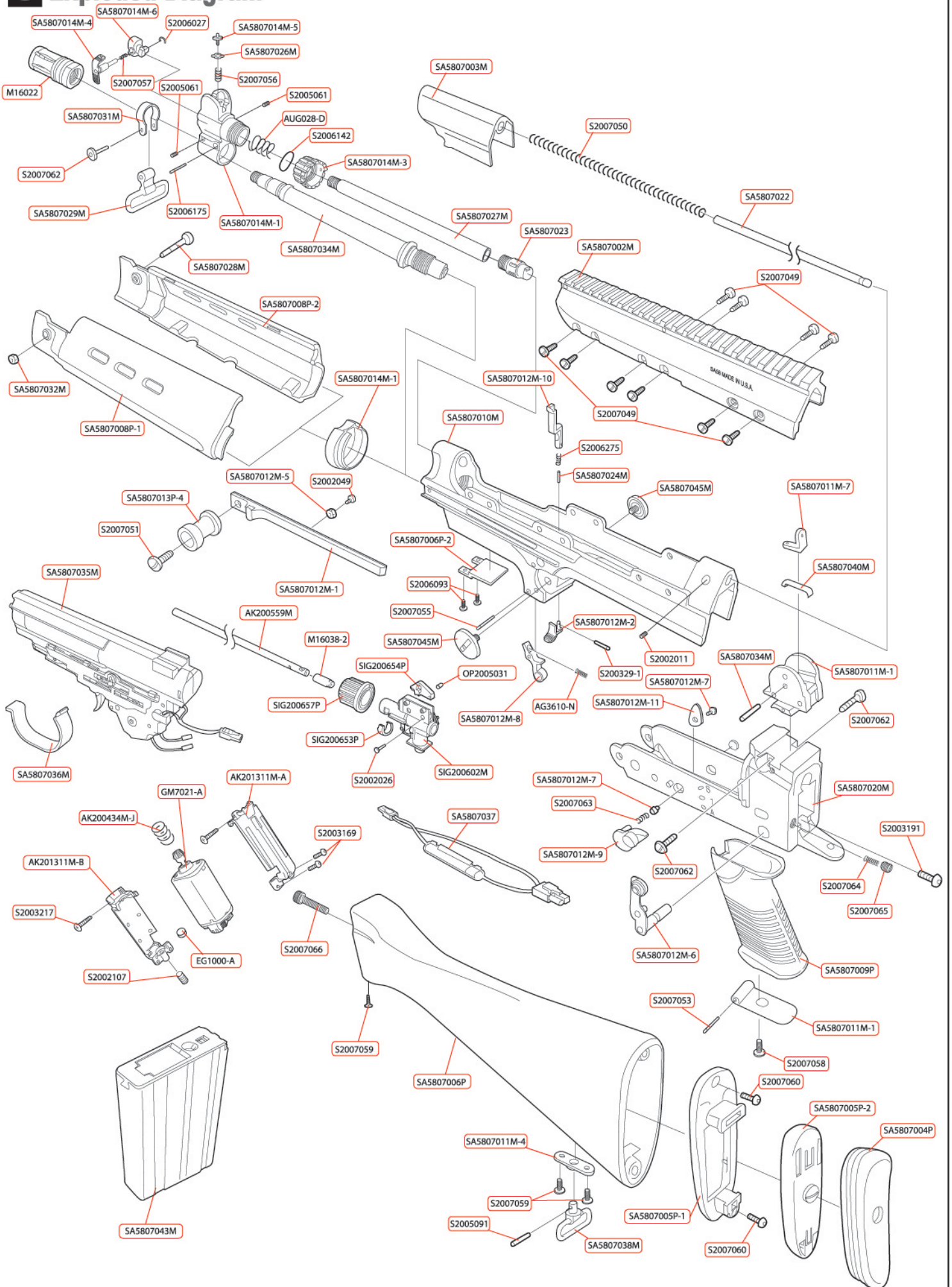



Website: www.classicarmy.com
E-mail: info@classicarmy.com

DSA Inc. LK BARRINGTON, IL

PDF por Sniper
Matadores Airsoft Club
www.matadoresairsoft.com



DSA and the DSA logo are registered trademarks of DSA inc. U.S.A., Used under exclusive worldwide license for Air Soft Guns by ASG A/S, Denmark, www.actionsportgames.com