



DRAGUNOV SVD

**AIRSOFT ELECTRIC GUN
METAL CASTING**

HANDLING CAUTIONS AND INSTRUCTION MANUAL

MODEL	WEIGHT	BARREL LENGTH	BARREL CALIBER	PELLET CAPACITY	PELLET	BATTERY TYPE
DRAGUNOV SVD	3.3kg	631mm	6.08mm	40	6mm BB	Mini Type(8.4v)

CA038M

info@classicarmy.com

www.classicarmy.com

1 Outlook / Structure of DRAGUNOV SVD

Always set the selector switch to the safe position when you are not firing or during storage

DRAGUNOV SVD

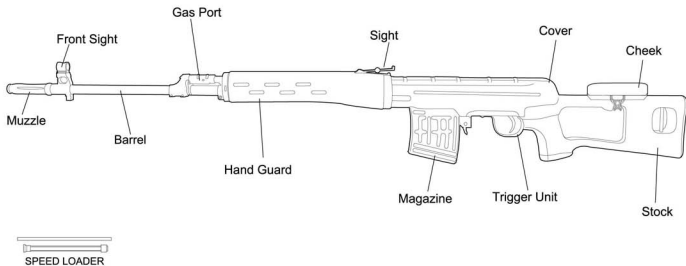

2 Specification

Data of Automatic Electric Gun

Name	DRAGUNOV SVD
Weight	3.3kg
Barrel Length	631mm
Barrel Caliber	6.08mm
Pellet Capacity	40
Pellet	6mmBB
Initial Pellet Speed	85~130m/s
Battery Type	Mini Type(8.4v)

3 Operation

1 How to use safety lock



2 How to fire

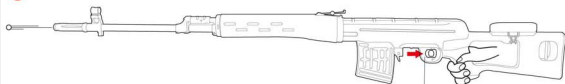

1 Switch the selector switch to Semi or Full Auto

* Blank firing may occur after setting the magazine, this is the normal operation of the gun.

Caution on Motor and Battery

Change the battery if the firing cycle becomes slow.
Give the air gun a rest for 3 to 10 minutes after firing about 500 pellets in order to ensure high durability of the motor and battery.

When pellets are clogged

If pellets are clogged, remove them and apply a few drops of silicone oil into the chamber from the magazine entrance as shown or spray silicone oil for 0.5 to 1 sec, to obtain smooth continuous firing (Never use CRC-556 or other mineral oil)



* There is possibility that no BB comes out after pulling the trigger in the semi auto mode. In that case do not pull the trigger furiously. Fire 5 to 10 pellets in the full auto mode and then return to the semi auto mode



* Small may be generated from the motor for a while when a new air gun is operated. This is the normal operation of the gun.



* The hop up operation may be unstable for 200 to 300 pellets after using silicone oil, this is the normal operation of the gun.

3 Hop up system adjustment

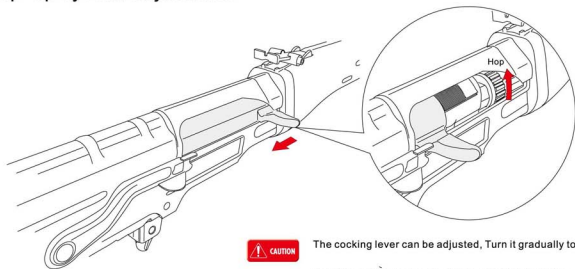

The cocking lever can be adjusted, Turn it gradually towards the hop.



Turn it excessively will adversely affect the trajectory. Stop turning it when pellets shoot horizontally.

4 Sight adjustment

Front Sight :



Counterclockwise:
Lower sight point

Clockwise:
Higher sight point



Insert the front sight adjustment tool in the front sight and turn it for adjustment.

Rear Sight :

Long distance

Short distance

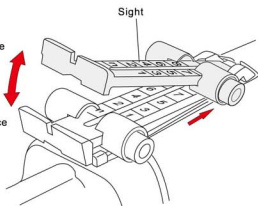

Press

Elevation (Up/Down)
adjustment button

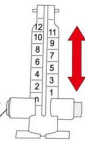

5 Magazine Attachment / Detachment Procedure

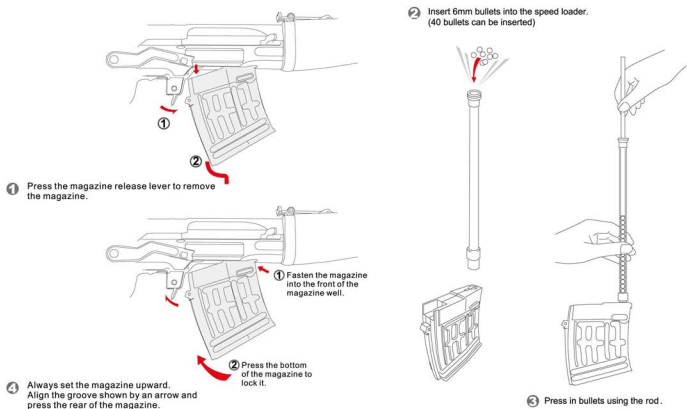

6 How to insert battery

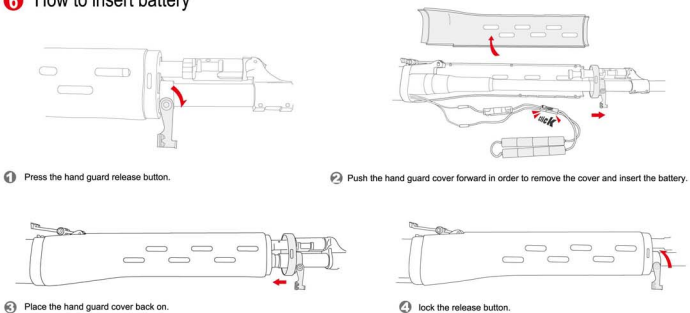

7 How to detach / attach the cheek pod.



8 How to detach / attach the top cover.

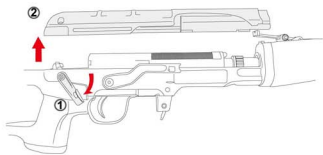

1 Press the release button to remove the cover.

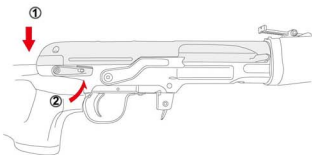

2 Place the cover back and lock the release button

9 How to use a cleaning rod

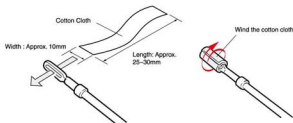

Cut a cotton cloth to the size as shown above and insert one end into the hole in the rod.
(Adjust the length of cloth for smooth entry into the barrel.)



Hold the tip of the rod and insert it with turning motion.



CAUTION: Always begin the maintenance by returning the hop up adjustment lever to NORMAL.

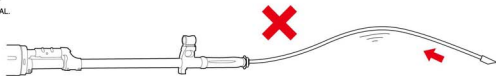

CAUTION: The chamber is a precision component.
Never use any used BB pellets.

* The hop-up performance may become unstable for 60 to 70 pellets after maintenance.



Inserting the rod will be difficult if you hold the rod at the end.

- Spray silicone oil for 0.5 to 1 sec in the pellet entrance, then fire 40 to 50 pellets to make the magazine stable.
- Clean the oil from the chamber using the cleaning rod (with cotton) to complete the maintenance.

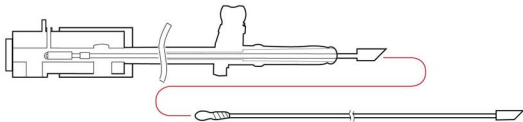

10 How to replace the fuse

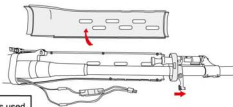

1 Open the hand guard carefully.



2 Open the fuse box and change the fuse.

30A Glass Tube Fuse is used.



CAUTION: Always begin the maintenance by returning the hop up adjustment lever to Normal.



Never use any used BB pellets

Use new 6mm BB pellet is a must



Please don't use incomplete BB.



Please don't use any broken BB pellet.



Please don't use any BB pellet which diameter exceeded 6 mm.

4 WARNING

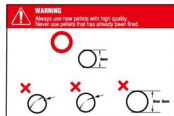

In no event shall Classic Army or any of our partners be liable for any direct or indirect, special, incidental, or consequential damages in connection with the use of our products.

5 For complete product information, dealer locations and technical support, please visit the website of Classic Army Sole Distributors.

Italy, San Marino Republic, Città del Vaticano, Spain (includes Andorra and Gibraltar) Portugal and Switzerland

Co. Name: Evolution International S.r.l.
 Add.: Via dell'Annunziata n.31, 20121 Milan, Italy
 Tel: (39) 02 25459027
 Fax: (39) 02 25118356
 Email: info@evolution-airsoft.com
 Website: www.evolution-airsoft.com

Denmark, Sweden, Norway & Finland, France, Germany, Austria, United Kingdom, Poland, Baltic countries, Belgium, Luxembourg, the Czech Republic and Slovakia

Add.: Bakkegaardvej 304, DK-3050 Humlebaek, Denmark
 Tel: (45) 89 28 18 88
 Fax: (45) 49 19 31 60
 Email: sales@actionsportgames.com
 Website: http://www.actionsportgames.com/

The United States of America

Co. Name: Spartan Imports, Inc.
 Add.: 213 Lawrence Avenue, S. San Francisco, California, USA 94080
 Tel: (1) 650 589 5501
 Fax: (1) 650 589 5552
 Email: info@spartanimports.com
 Website: http://www.spartanimports.com/

Taiwan

Co. Name: F-Links HiFi Enterprise Co. Ltd.
 Add.: No. 3 Lane 82, Jianguo 1st Rd., Lingya District, Kaohsiung City 802, Taiwan, R.O.C.
 Tel: (886) 7-710 0198
 Fax: (886) 7-710 0398
 Email: kasa.kasa@msa.hinet.net
 Website: http://www.soldan.com.tw/

Thailand

Co. Name: Vitech Co., Ltd
 Add.: 92 Kasat - Nawaenrieta Rd. Soi Ladplaoze 39 Jorakheua Ladymno Bangkok
 Tel: +662 9402629 / auto 4 lines | +668 1 8692117
 Fax: +662 9402679
 Email: polaris_adventure@yahoo.com
 Website: http://www.classicarmy-thailand.com

Japan

Co. Name: Union Fire Company (UFC)
 Add.: 5-2-087 5-10-101 - MATSUYAMACHI, CHUO-KU, OSAKA, JAPAN
 Tel: +81-6-4304-7750
 Fax: +81-6-4304-7799
 Email: ufc Trading@ufc-web.com
 Website: http://www.ufc-web.com/

Ukraine

Co. Name: Vizariya-1
 Add.: Kiev Av. A. Navoi, 7/6, Ukraine
 Tel: (380)44 4084369
 Fax: (380)44 4060633
 Email: vizariya_1@evtomline.com
 Website: http://www.milart.com.ua/

6 Exploded Diagram

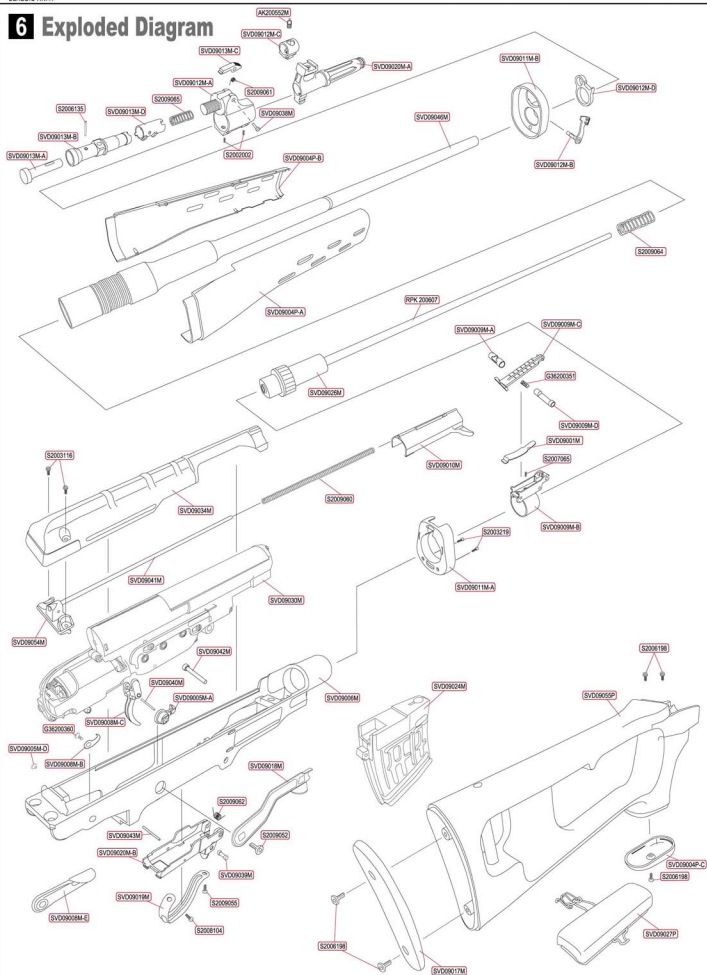



UNIVERSO SNIPER
AIRSOFT



WARNING

- FOR AGE 18 OR ABOVE.
- PLEASE READ THE INSTRUCTIONS CAREFULLY BEFORE USE.
MISUSE OR CARELESS USE MAY CAUSE SERIOUS INJURY.
- USER SHOULD OBEY TO THE LAWS REGARDING THE USAGE AND OWNERSHIP
OF AIRSOFT ELECTRIC GUNS.
- FACIAL PROTECTION IS REQUIRED.