

WARNING

- To avoid damaging the product, please release the gas from the magazines or cartridges while not operating.
- Sales and usage are restricted to 18-year-old people or older. Those below 18 years old are not allowed neither to purchase nor to operate alone.
- Never aim or shoot at people or animals. Please beware of childrens' mis-handling.
- Please read and fully understand all details listed in this instruction manual before using this air gun. You can download it from www.icsbb.com if you lose this instruction manual.

6mm BB



1 PART DESCRIPTION

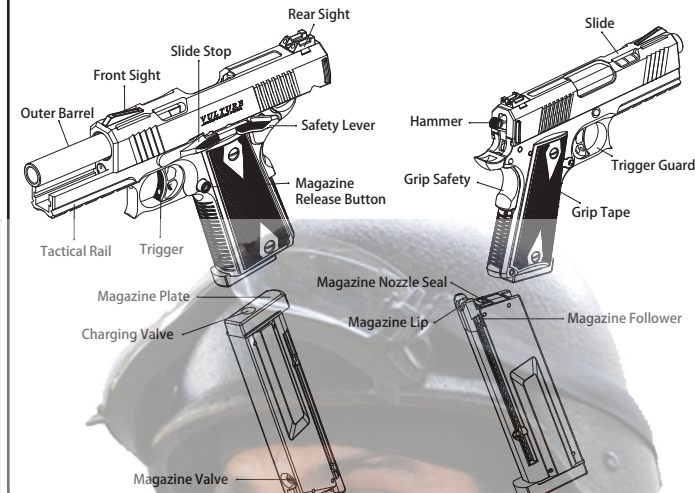

WARNING-ATTENTION



This model is featured with Gas-Blow-Back function. The slide will be pushed back and forth by the gas pressure strongly and rapidly while firing. To prevent injury, please keep your face and finger away from the slide.

The pistol could be damaged when using at temperature of 35°C (95°F) or above.

2 SAFETY DEVICE

Safety ON
Engage the safety by pressing down the hammer to locking position, then switch the Safety Lever upward.

Safety OFF
Disengage the safety when you are going to fire.

The trigger and slide are not able to pull when the safety is engaged.



The trigger cannot be pulled without holding the grip safety.



The trigger can be pulled when holding the grip safety firmly.

3 LOADING MAGAZINE

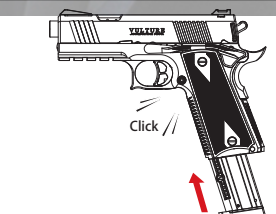

Load the magazine until it clicks into the locking position.
Do not insert the magazine by force.



Release the magazine by pressing the magazine catch button.
Hold the magazine when releasing it from the pistol grip to prevent it from dropping.

WARNING-ATTENTION

To prevent misfiring, keep your finger off the trigger and out of the trigger guard while loading the magazine.
For safety reason, please remove the magazine while not operating.

4 CHARGING GAS

For the optimum product performance, please charge your magazine with 10-12kg airsoft use green gas. If you use green gas with non-recommended number of kg, it may cause damage or malfunction to the product.

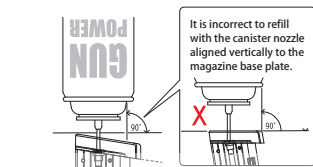

Please turn the magazine up side down to keep the injection hole side up, fill the gas only when the canister is verticalize to the injection hole.
The gas will not be filled into the magazine or will leak out if the canister is not verticalize to the injection hole.

WARNING-ATTENTION

Please avoid to touch the injection hole. It might cause frostbites or low temperature burns if the gas adheres to the skin.
To preserve the magazine. Magazines are very delicate parts, dropping them may cause damage or abnormality.
Please avoid foreign matter remains on the magazine lip and injection hole on the magazine, which may cause abnormality.
If refilling is necessary, please avoid to proceed when the magazine is loaded. Please unload the magazine before proceed.
Please do not place the magazines in wet or watery places, which may cause an abnormality.

Precautions while filling:
If you fill the magazine with a non-vertical way from up towards down, and caused the magazine is not completely filled, please deflate the gas completely, and refill the gas one more time as instructed.
Fill the gas until the gas starts to leak out. When the gas is fully filled, gas inside the gas canister and magazine are balance without refilling anymore. It is the normal condition that the gas starts to leak out because it is not able to keep filling. Please stop filling immediately.
Please use your magazine under normal temperature!
If operating in environment of 20°C or below, the gas pressure will drop and might cause abnormal functions. (The magazine will work normally again when temperature returns to normal temperature.)
If operating in environment of 35°C or above, the gas pressure will be too high and might cause abnormal functions. (The magazine will work normally again when temperature returns to normal temperature.)
If you fill the magazine with gas and fire dozens of shots even under normal temperature, the gas pressure will also drop and cause the gas temperature to drop. Preparing several spare magazines for exchange is recommended.

5 LOADING BBs

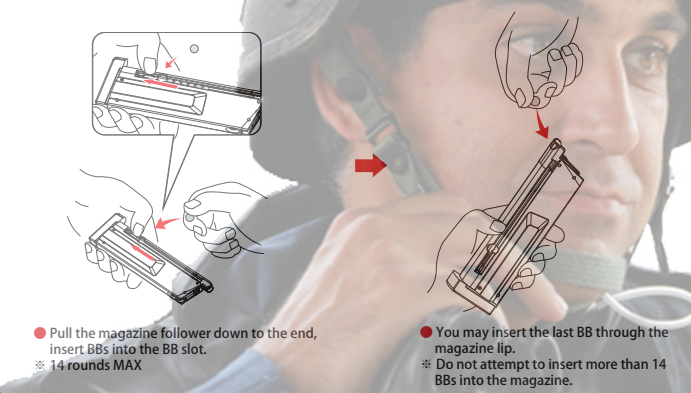

WARNING-ATTENTION

Do not release the magazine follower abruptly while pressing the follower. Releasing the follower carelessly may damage the magazine lip.

Pull the magazine follower down to the end, insert BBs into the BB slot. 14 rounds MAX.
You may insert the last BB through the magazine lip.
Do not attempt to insert more than 14 BBs into the magazine.

6 Trigger Pull Adjustment



Please use an 2mm Allen wrench to adjust the trigger pull hex screw.
Please adjust according to personal habit.
The trigger could be locked by fastening the hex screw to the end, please release the screw properly.

7 Loading

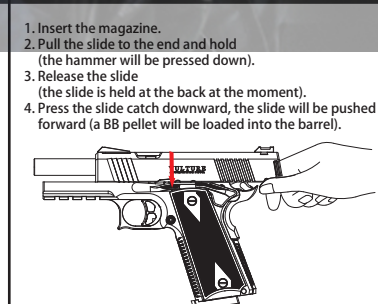

WARNING-ATTENTION

Keep your face and fingers away from the slide while the slide is operating.
When the pistol is unloaded, the slide can be pushed forward when you pull and release it from the end.
When the pistol is loaded, loading repeatedly will makes the BBs load into the barrel repeatedly, which will lead to malfunction while firing and cause danger.
When the hammer is pressed down, pulling the trigger will fire the BB. Please take extra notice.

8 SHOOTING

- Pressing the safety lever down to FIRE.
- Load the pistol according to step 6.
- Pull the trigger to fire (a BB pellet will be fired and the slide will be pushed backward).



To prevent misfiring, keep your finger off the trigger and out of the trigger guard when you are not ready to fire.

When the BB is loaded into the barrel, the following process will be proceeded and repeat automatically everytime you pull the trigger.
BB fired → slide movement (blowed backward) → Load the next BB (slide re-positioned)

ATTENTION
The rails on the slide is very sharp. Please keep your face and fingers away from the slide while the slide is operating.
Please keep your finger off the trigger and out of the trigger guard, and take extra caution to where the gun is aiming while proceeding non-firing operations.

The slide will be blown back and forth when firing.

WARNING-ATTENTION

Power Depression
When the temperature inside the magazine is too low, the gas power will be depressed.
The movement of the slide will be delayed.
The slide catch will not be bounced.
The shooting range will not be far.



Shooting posture
Please do not operate the pistol up side down for optimum performance.



9 STORAGE

- Press the magazine catch button to release the magazine.
- Make sure the inner barrel is clear. If not, pull the slide backward, and turn the pistol up side down to remove the remaining BB, make sure no BBs are left inside the barrel. (push the BB pellet out from the barrel by the clearing rod is recommended).
- Press the slide catch lever to release the slide.
- Pull the trigger and fire several times towards safety directions, and make sure no BBs are left inside the barrel.

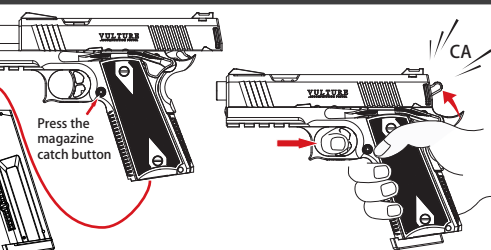

10 Disassemble the Compensator (Tactical Ver. Only)

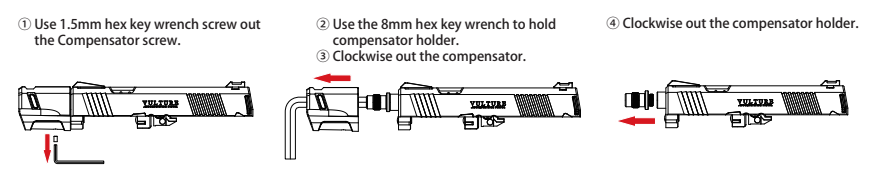

11 DISASSEMBLY (Do it when necessary)

Only disassemble your airsoft replica when adjusting the H-UP and proceeding to maintenance.

① Press the magazine catch to unload the magazine.

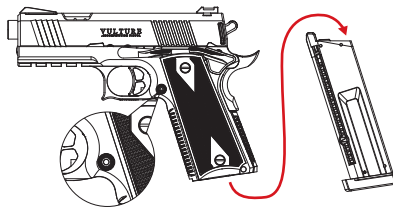

② Pull the slide backward until the slide stop is aligned to the 1st notch from the left as shown.
③ Press the slide stop button on the right to remove the slide stop.

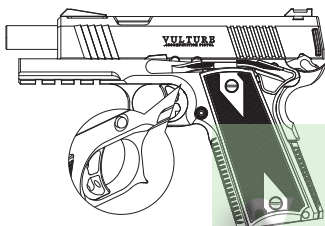

④ Push the slide forward to remove.

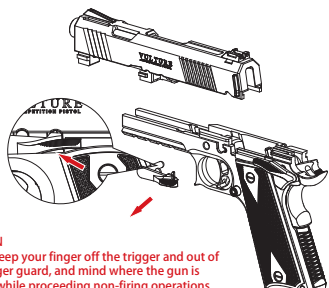

ATTENTION
△ Please keep your finger off the trigger and out of the trigger guard, and mind where the gun is aiming while proceeding non-firing operations.

⑤ Slightly push the outer barrel assembly forward, and then remove it upward.

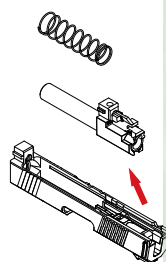

12 H-UP ADJUSTMENT

① Please disassemble and remove the slide as step 11 instructed.
② Slightly rotate the dial to adjust the H-UP.

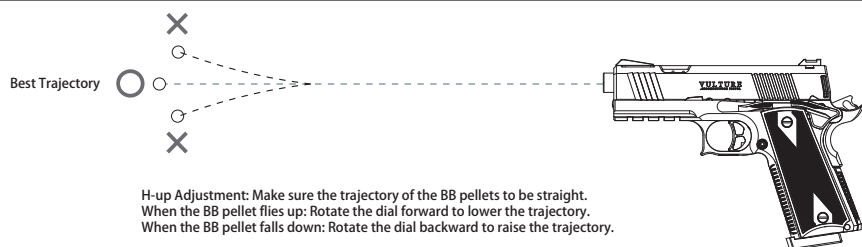
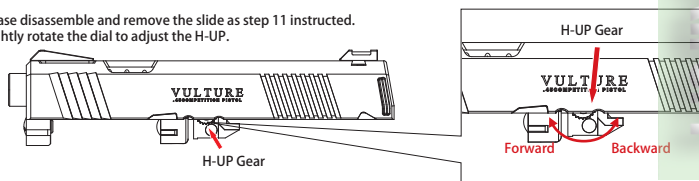

13 ASSEMBLY

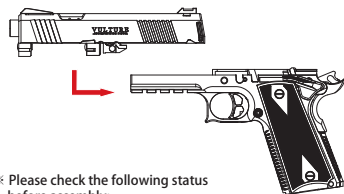

※ Please check the following status before assembly:
△ The hammer must be down pressed.

① Insert the slide back to the receiver through the rail from the front.
② Pull the slide backward until the slide stop is aligned to the 1st notch from the left as shown.
③ Insert the slide stop back to position, then release the slide.
④ Load the magazine.

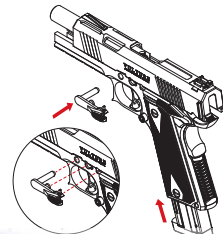

WARNING · ATTENTION

● ICS will not be responsible for any part assembling errors, missing parts, and problems such as malfunctions, accidents, injuries, caused by malfunction, and all the maintaining expenses will be borne by the customer themselves.

14 BASIC TROUBLESHOOTING GUIDE

SYMPTOMS	POSSIBLE CAUSES	SOLUTIONS
No Response	The safety is ON. (No firing)	Switch the safety to "OFF" (refer to step 2)
	Magazine overpressured.	Press the valve gently to release gas and to adjust pressure. Be careful when gas is discharged from the nozzle seal.
	Insufficient gas inside the magazine.	Charge gas into magazine (refer to step 4)
The slide blows back but no BB is fired.	BB can't be loaded into the barrel.	Load the first BB into the barrel (refer to step 7)
	BB is jammed inside the magazine.	Push out the BB by using the clearing rod, or pulling the slide backward, and turn the pistol up side down to remove.
Will not complete cycle	Magazine is too cold.	Use the magazine after it is returned to normal temperature (refer to step 4).
	Temperature is too low.	Use the magazine after it is returned to normal temperature (refer to step 4).
	Magazine is too cold.	Use the magazine after it is returned to normal temperature (refer to step 4).
Slide jammed	No gas in the magazine.	Charge gas into magazine (refer to step 4)
	Lubricant or silicon oil is not enough.	Apply lubricant to the moving aptrts.
	BBs or foreign matters jammed inside the slide or frame.	Remove the BBs or foreign matters.
Gas comes out from the barrel	Slide release button is not switched back to locking position.	Switch the slide release button to horizontal locking position (refer to step 11)
	Temperature is too low.	Use the magazine after it is returned to normal temperature (refer to step 4).
BBs fly up	Magazine is too cold.	Use the magazine after it is returned to normal temperature (refer to step 4).
	H-UP is over adjusted.	Adjust the H-UP gear forward.
Shooting range is too short	H-UP isn't adjusted enough.	Adjust the H-UP gear backward.
	Foreign matters or oil in the inner barrel.	Clean the inner barrel and H-UP bucking.
BBs roll out of barrel	H-UP isn't adjusted enough.	Adjust the H-UP gear forward.
Jammed	H-UP is over adjusted.	Adjust the H-UP gear backward.
	Bad BBs, oversize BBs	0.2g to 0.25g 6mm caliber BBs are recommended for optimum performance.
	Foreign matters or oil in the inner barrel.	Clean the inner barrel.

15 PARTS DIAGRAM

*The components/accessories for each model may have kind of differences depending on the actual goods. Images are only for reference.

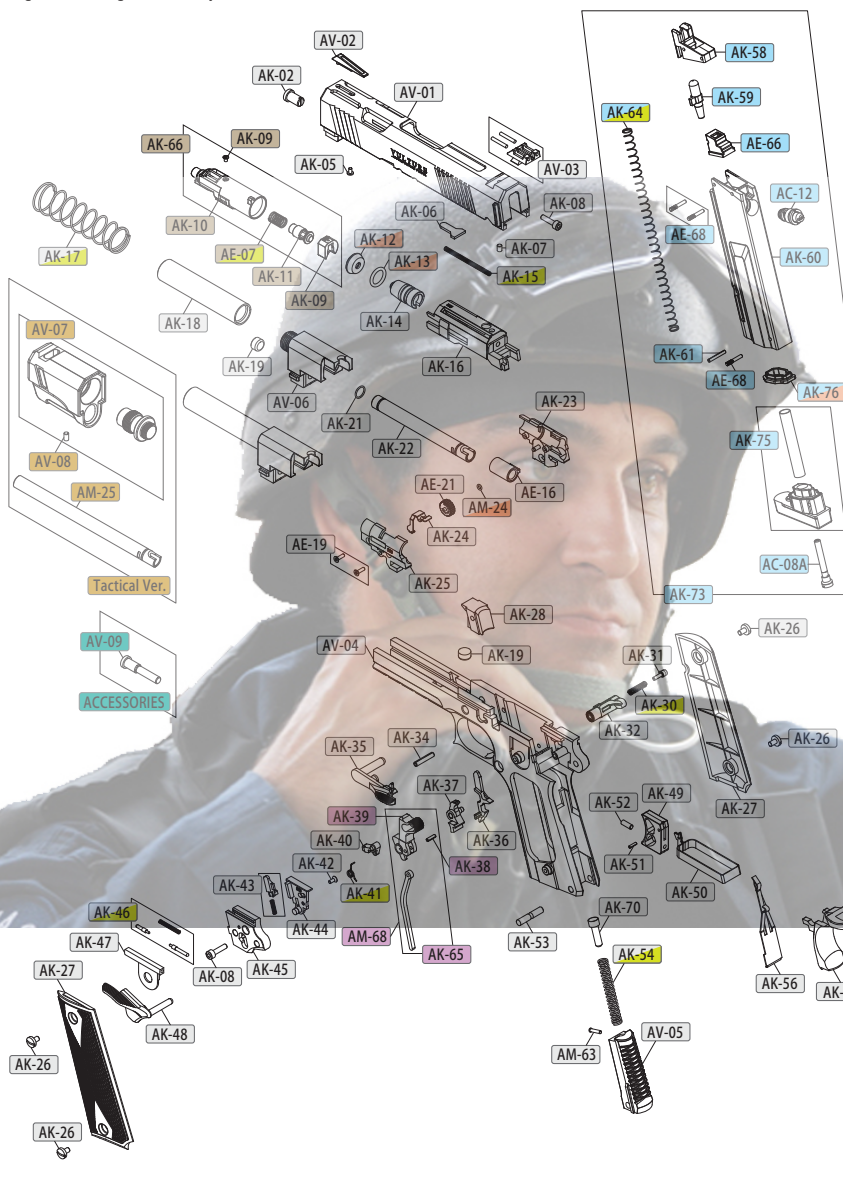

16 PARTS DESCRIPTION

ITEM#	DESCRIPTION	Q'TY	ITEM#	DESCRIPTION	Q'TY
AK-02	Slide Buffer Screw	1	AK-49	Vulture Trigger	1
AK-05	Front Sight Screw	1	AK-50	Vulture Trigger Bar	1
AK-06	Vulture Shell Hook	1	AK-51	Trigger Bar Pin	1
AK-07	Vulture Rear Sight Screw	1	AK-52	Trigger adjustment Screw	1
AK-08	Cylinder Housing and Hammer Screw	2	AK-53	Vulture Hammer Spring Housing Pin	1
AK-09	Vulture Valve Cover with Screw	1	AK-54	Hammer Spring	1
AK-10	Vulture Cylinder	1	AK-56	Vulture Sear Spring	1
AK-11	Vulture Valve	1	AK-57	Vulture Grip Safety	1
AK-12	Vulture Valve Plate	1	AK-58	Vulture Magazine Lip	1
AK-13	Cylinder Cover Housing O-Ring	1	AK-59	Vulture Magazine Follower	1
AK-14	Vulture Cylinder Cover Housing	1	AK-60	Vulture Magazine Case	1
AK-15	Vulture Cylinder Housing Spring	1	AK-61	Magazine Base Plate Stop Pin	1
AK-16	Vulture Cylinder Housing	1	AK-62	Magazine Base Plate O-Ring	1
AK-17	Vulture Recoil Spring	1	AK-64	Magazine Follower Spring	1
AK-18	4" Vulture Outer Barrel	1	AK-65	Vulture Hammer Combination	1
AK-19	Slide Buffer	2	AK-66	Vulture Cylinder Combination	1
AK-21	Inner Barrel O-Ring	1	AK-67	Vulture Spring Package	1
AK-22	Inner Barrel (85.5mm)	1	AK-69	O-Ring Parts	1
AK-23	Vulture H-UP Chamber-Right	1	AK-70	Vulture Hammer Spring Holder (5pcs)	1
AK-24	Vulture H-UP Plate	1	AK-73	Vulture Magazine (Thick Base)	1
AK-25	Vulture H-UP Chamber-Left	1	AK-75	Magazine Base-Thick	1
AK-26	Grip Tape Screw	4	AK-76	Magazine Base Plate O-Ring (10pcs)	1
AK-27	Vulture Grip Tape	2	AC-08A	Revo Energy Magazine Nozzle	1
AK-28	Vulture H-UP Chamber Holder	1	AC-12	Revo.II Efficient Gas Release Valve	1
AK-30	Vulture Magazine Catch Spring	1	AE-07	XAE Valve Spring (10pcs)	1
AK-31	Vulture Magazine Catch Lock	1	AE-16	XAE H-UP Bucking (10pcs)	1
AK-32	Vulture Magazine Catch	1	AE-19	XAE H-UP Chamber Screw (20pcs)	2
AK-33	Vulture Frame-BK	1	AE-21	H-UP Dial (2pcs)	1
AK-34	Vulture H-UP Chamber Holder Pin	1	AE-66	XAE Magazine Nozzle Seal (10pcs)	1
AK-35	Vulture Slide Catch Lever Plate	1	AE-68	XAE Magazine Lip Pin (10pcs)	3
AK-36	Vulture Hammer Disconnect Pin	1	AM-24	O-ring (20pcs)	1
AK-37	Vulture Sear with Pin	1	AM-25	Inner Barrel (115mm)	1
AK-38	Hammer Brace Rod Pin	1	AM-63	BM9 Hammer Spring Holder Pin	1
AK-39	Vulture Hammer	1	AM-68	BM9 Hammer Brace Rod (2pcs)	1
AK-40	Vulture Hammer Knocker	1	AV-01	Vulture Slide	1
AK-41	Vulture Hammer Knocker Spring	1	AV-02	Vulture Front Sight (2pcs)	1
AK-42	Hammer Housing Screw	1	AV-03	Vulture Fiber Optic Rear Sight (w/ Fiber Optic)	1
AK-43	Vulture Hammer Disconnect Pin and Spring	1	AV-04	Vulture Frame	1
AK-44	Vulture Hammer Disconnect Pin Housing	1	AV-05	Vulture Hammer Spring Housing	1
AK-45	Vulture Hammer Combination Housing	1	AV-06	Vulture Chamber	1
AK-46	Vulture Slide Catch Lever Pin and Spring	1	AV-07	Vulture Compensator & Compensator Holder (w/ Screw)	1
AK-47	Vulture Slide Catch Lever Pin Housing	1	AV-08	Vulture Compensator Screw (20 pcs)	1
AK-48	Vulture Slide Safety	1	AV-09	Vulture Slide Stop Screw (5 pcs)	1