



Please read the [ Instruction Manual ] carefully and make full understanding of the details noted in the contents before use.

**WARNING**

- To avoid damaging the product, please release the gas from the magazines or cartridges while not operating.
- Sales and usage are restricted to 18-year-old people or older. Those below 18 years old are not allowed neither to purchase nor to operate alone.
- Never aim or shoot at people or animals. Please beware of childrens' mis-handling.
- Please read and fully understand all details listed in this instruction manual before using this air gun. You can download it from [www.icsbb.com](http://www.icsbb.com) if you lose this instruction manual.

6mm BB



**1 PART DESCRIPTION**

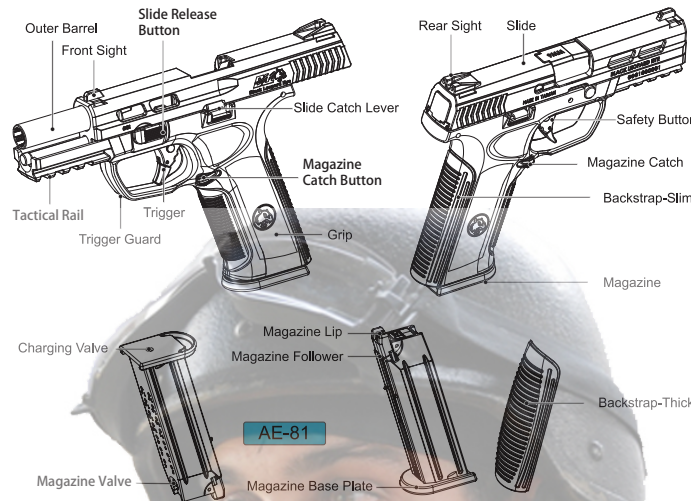

**WARNING-ATTENTION**

This model is featured with Gas-Blow-Back function. The slide will be pushed back and forth by the gas pressure strongly and rapidly while firing. To prevent injury, please keep your face and finger away from the slide.

The pistol could be damaged when using at temperature of 35°C (95°F) or above.

**2 SAFETY DEVICE**



**3 LOADING MAGAZINE**

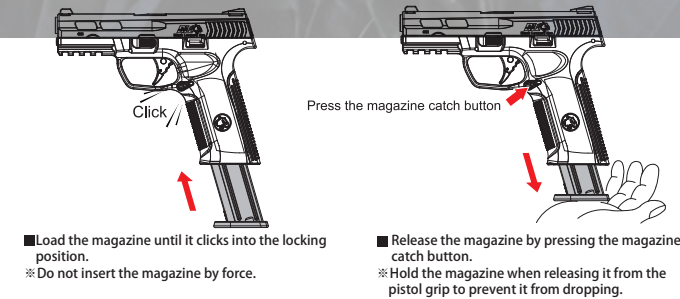

**WARNING-ATTENTION**

To prevent misfiring, keep your finger off the trigger and out of the trigger guard while loading the magazine. For safety reason, please remove the magazine while not operating.

**4 CHARGING GAS**

For the optimum product performance, please charge your magazine with 10-12kg airsoft use green gas. If you use green gas with non-recommended number of kg, it may cause damage or malfunction to the product.

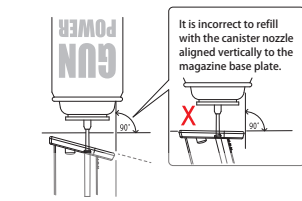

Please turn the magazine up side down to keep the injection hole side up, fill the gas only when the canister is verticalized to the injection hole. The gas will not be filled into the magazine or will leak out if the canister is not verticalized to the injection hole.

**WARNING-ATTENTION**

Please avoid to touch the injection hole. It might cause frostbites or low temperature burns if the skin is adhered by the gas. To preserve the magazine, Magazines are very delicate parts. Dropping them may cause damage or abnormality. Please avoid foreign matter remains on the magazine lip and injection hole on the magazine, which may cause abnormality. If refilling is necessary, please avoid to proceed when the magazine is loaded. Please unload the magazine before proceeding. Please do not place the magazines in wet or watery places, which may cause abnormality.

**Precautions while filling:**  
If you fill the magazine with a non-vertical way from up towards down, and caused the magazine is not completely filled, please deflate the gas completely, and refill the gas one more time as instructed.  
Fill the gas until the gas starts to leak out. When the gas is fully filled, gas inside the gas canister and magazine are balance without refilling anymore. It is the normal condition that the gas starts to leak out because it is not able to keep filling. Please stop filling immediately.  
Please use your magazine under normal temperature!  
If operating in environment of 20°C or below, the gas pressure will drop and might cause abnormal functions. (The magazine will work normally again when temperature returns to normal temperature.)  
If operating in environment of 35°C or above, the gas pressure will be too high and might cause abnormal functions. (The magazine will work normally again when temperature returns to normal temperature.)  
If you fill the magazine with gas and fire dozens of shots even under normal temperature, the gas pressure will also drop and cause the gas temperature to drop. Preparing several spare magazines for exchange is recommended.

**5 LOADING BBs**

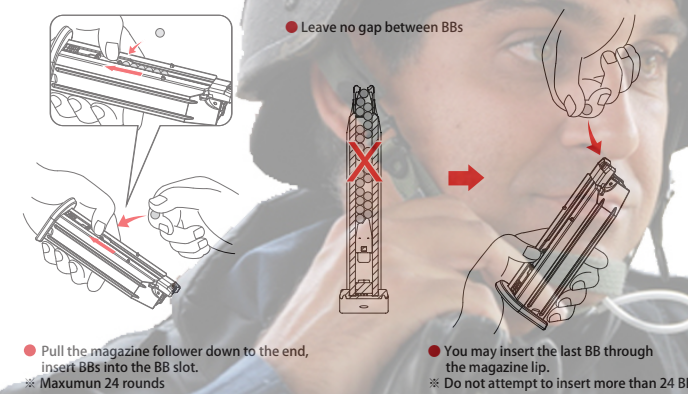

**WARNING-ATTENTION**

Do not release the magazine follower abruptly while pressing the follower. Releasing the follower carelessly may damage the magazine lip.

**6 LOADING**

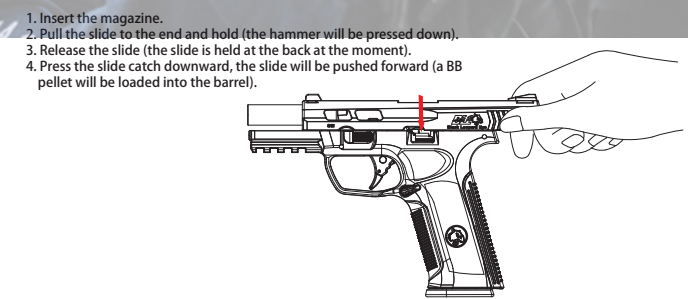

**WARNING-ATTENTION**

Keep your face and fingers away from the slide while the slide is operating. When the pistol is unloaded, the slide can be pushed forward when you pull and release it from the end. When the pistol is loaded, loading repeatedly will makes the BBs load into the barrel repeatedly, which will lead to malfunction while firing and cause danger. When the hammer is pressed down, pulling the trigger will fire the BB. Please take extra notice.

**7 SHOOTING**

1. Switch the safety to FIRE.  
2. Load the pistol according to step 6.  
3. Pull the trigger to fire (a BB pellet will be fired and the slide will be pushed backward).

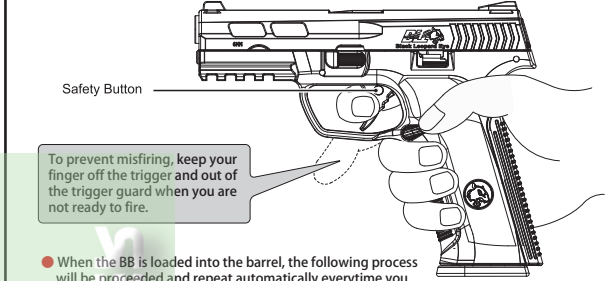

When the BB is loaded into the barrel, the following process will be proceeded and repeat automatically everytime you pull the trigger: BB fired → Slide movement (blowed backward) → Load the next BB (slide re-positioned)

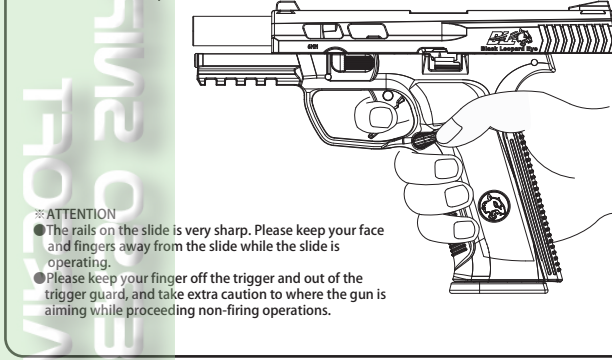

**WARNING-ATTENTION**

Power Depression: When the temperature inside the magazine is too low, the gas power will be depressed. The movement of the slide will be delayed. The slide catch will not be bounced. The shooting range will not be far.

Shooting posture: Please do not operate the pistol up side down for optium performance.

**8 STORAGE**

1. Press the magazine catch button to release the magazine.  
2. Make sure the inner barrel is clear. If not, pull the slide backward, and turn the pistol up side down to remove the remaining BB, make sure no BBs are left inside the barrel. (push the BB pellet out from the barrel by the clearing rod is recommended).  
3. Press the slide catch lever to release the slide.  
4. Pull the trigger and fire several times towards safety directions, and make sure no BBs are left inside the barrel.

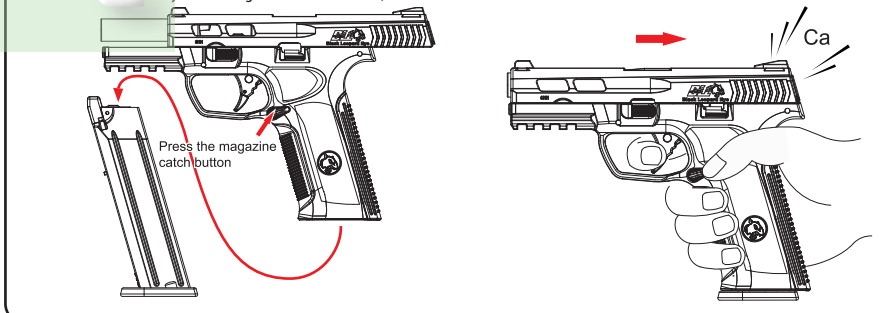

## 9 DISASSEMBLY (Do it when necessary)

Only disassemble your airsoft replica when adjusting the H-UP and proceeding to maintenance.

- Press the magazine catch button to unload the magazine.
- Pull and hold the slide to the end.

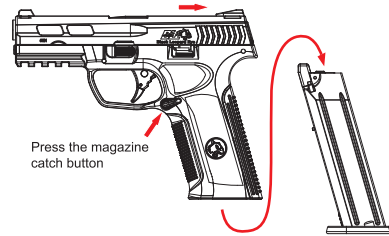

Press the magazine catch button

- Push the slide catch lever upward to hold the slide at the rear.
- Turn the slide release button downward to head 6 O'clock direction, hold your slide with your hand then press the slide catch lever.

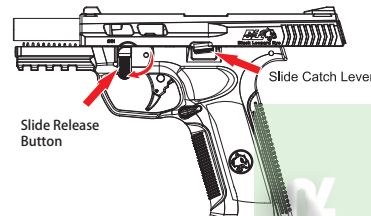

Slide Release Button

Slide Catch Lever

- Push the slide forward to remove.

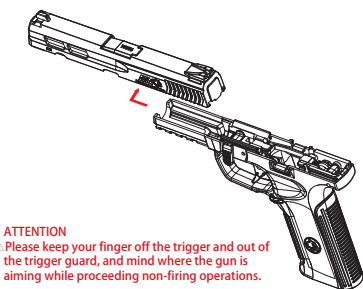

**ATTENTION**  
Please keep your finger off the trigger and out of the trigger guard, and mind where the gun is aiming while proceeding non-firing operations.

- Push the recoil spring guide forward to detach from the slide, then remove it upward.
- Slightly push the outer barrel assembly forward, and then remove it upward.

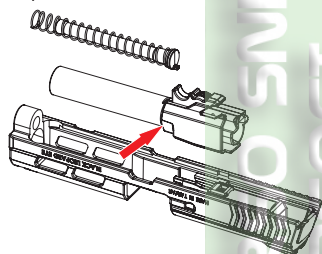

## 10 H-UP ADJUSTMENT

- Please disassemble and remove the slide as step 9 instructed.
- Slightly rotate the dial to adjust the H-UP.

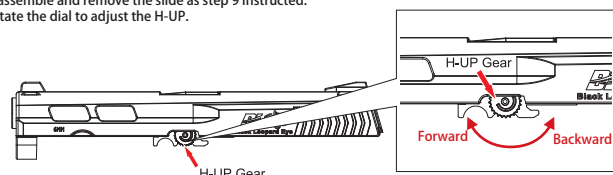

H-UP Gear

Forward Backward

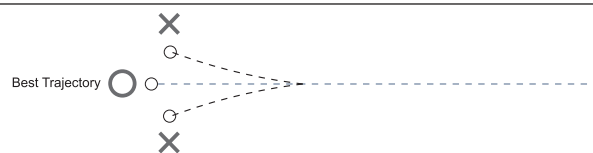

Best Trajectory

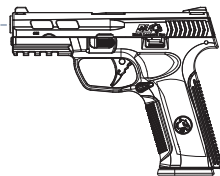

H-up Adjustment: Make sure the trajectory of the BB pellets to be straight. When the BB pellet flies up: Rotate the dial forward to lower the trajectory. When the BB pellet falls down: Rotate the dial backward to raise the trajectory.

## 11 ASSEMBLY

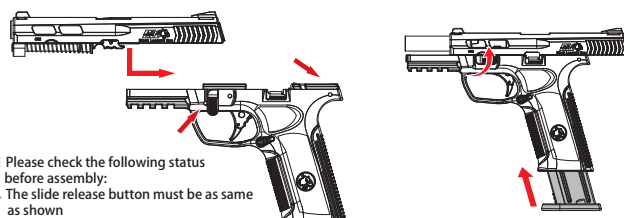

\* Please check the following status before assembly:  
△ The slide release button must be as same as shown  
△ The hammer must be down pressed.

- Insert the slide back to the receiver through the rail from the front.
- Push and hold the slide to the end.
- Turn the slide release button back to its horizontal position, then release the slide.
- Load an empty magazine.

**WARNING-ATTENTION**

ICS will not be responsible for any part assembling errors, missing parts, and problems such as malfunctions, accidents, injuries, caused by malfunction, and all the maintaining expenses will be bearred by the customer themselves.

## 12 BASIC TROUBLESHOOTING GUIDE

SYMPTOMS	POSSIBLE CAUSES	SOLUTIONS
No Response	The safety is ON. (No firing)	Switch the safety to "OFF" (refer to step 2)
	Magazine overpressured.	Press the valve gently to release gas and to adjust pressure. Be careful when gas is discharged from the nozzle seal.
	Insufficient gas inside the magazine.	Charge gas into magazine (refer to step 4)
The slide blows back but no BB is fired.	BB can't be loaded into the barrel.	Load the first BB into the barrel (refer to step 6)
	BB is jammed inside the magazine.	Push out the BB by using the clearing rod, or pulling the slide backward, and turn the pistol up side down to remove.
Will not complete cycle	Magazine is too cold.	Use the magazine after it is returned to normal temperature (refer to step 4).
	Temperature is too low.	Use the magazine after it is returned to normal temperature (refer to step 4).
	Magazine is too cold.	Use the magazine after it is returned to normal temperature (refer to step 4).
Slide jammed	No gas in the magazine.	Charge gas into magazine (refer to step 4)
	Lubricant or silicon oil is not enough.	Apply lubricant to the moving aprts.
	BBs or foreign matters jammed inside the slide or frame.	Remove the BBs or foreign matters.
Gas comes out from the barrel	Slide stop is in the locking position.	Switch the slide release button to horizontal locking position.
	Temperature is too low.	Use the magazine after it is returned to normal temperature (refer to step 4).
BBs fly up	Magazine is too cold.	Use the magazine after it is returned to normal temperature (refer to step 4).
	H-UP is over adjusted.	Adjust the H-UP gear forward.
Shooting range is too short	H-UP isn't adjusted enough.	Adjust the H-UP gear backward.
	Foreign matters or oil in the inner barrel.	Clean the inner barrel and H-UP bucking.
BBs roll out of barrel	H-UP isn't adjusted enough.	Adjust the H-UP gear forward.
	H-UP is over adjusted.	Adjust the H-UP gear backward.
Jammed	Bad BBs, oversize BBs	0.2g to 0.25g 6mm caliber BBs are recommended for optimum performance.
	Foreign matters or oil in the inner barrel.	Clean the inner barrel.

## 13 PARTS DIAGRAM

\*The components/accessories for each model may have kind of differences depending on the actual goods. Images are only for reference.

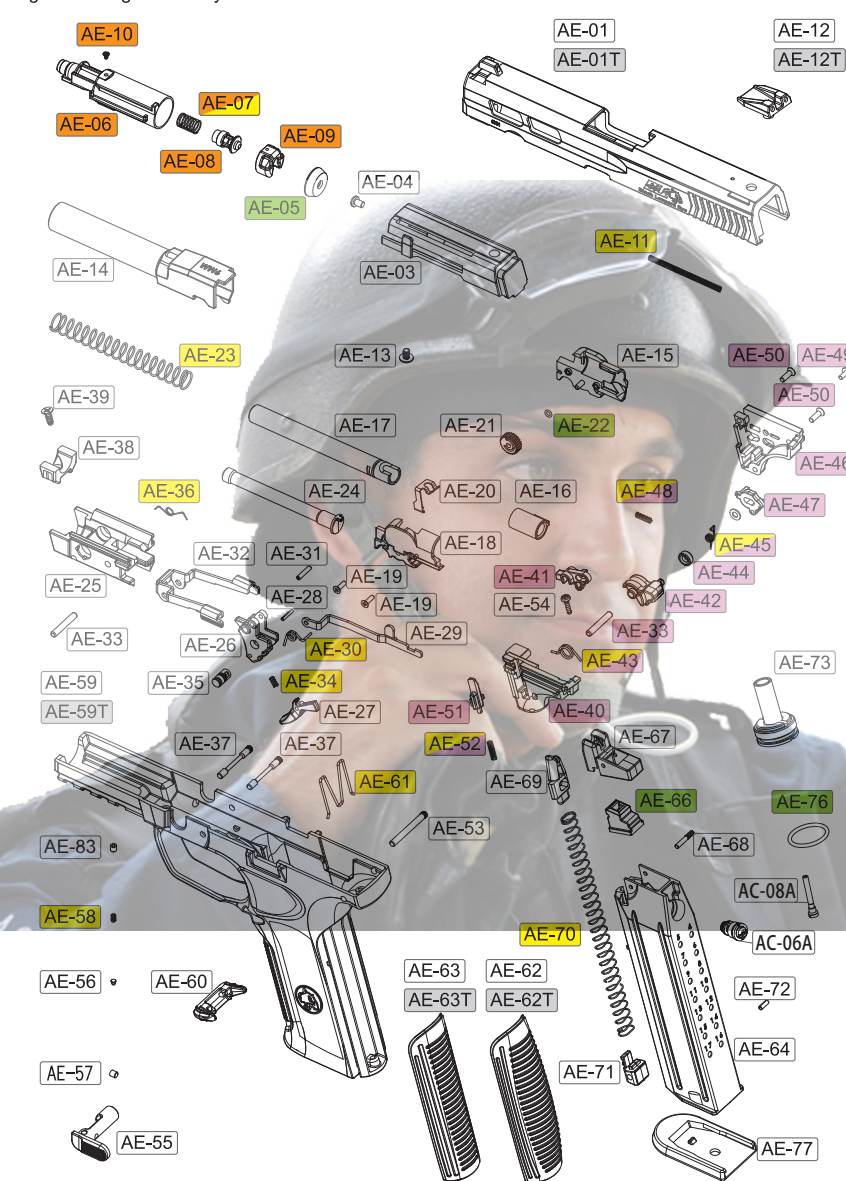

## 14 PART DESCRIPTION

ITEM#	DESCRIPTION	Q'TY	ITEM#	DESCRIPTION	Q'TY
AE-01	XAE Slide and Dummy Extractor	1	AE-43	XAE Hammer Spring	1
AE-01T	XAE Slide and Dummy Extractor-TAN	1	AE-44	XAE Hammer Guide Wheel	1
AE-03	XAE Cylinder Housing	1	AE-45	XAE Knocker Spring	1
AE-04	M1 Screw	1	AE-46	XAE Hammer Housing-Right	1
AE-05	XAE Piston Ring	1	AE-47	XAE Hammer Disconnecter	1
AE-06	XAE Cylinder	1	AE-48	XAE Hammer Disconnecter Spring	1
AE-07	XAE Valve Spring	1	AE-49	Round Head Hammer Housing Screw	1
AE-08	XAE Valve	1	AE-50	Flat Head Hammer Housing Screw	2
AE-09	XAE Cylinder Cover	1	AE-51	XAE Hammer Disconnect Pin	1
AE-10	XAE Cylinder Housing Screw	1	AE-52	XAE Hammer Disconnect Pin Spring	1
AE-11	Cylinder Housing Spring	2	AE-53	XAE Hammer Housing Pin	1
AE-12	XAE Rear Sight	1	AE-54	Hammer Housing Screw	1
AE-12T	XAE Rear Sight-TAN	1	AE-55	XAE Slide Takedown Lever	1
AE-13	Rear Sight Screw	1	AE-56	XAE Slide Takedown Lever Button	1
AE-14	XAE Outer Barrel	1	AE-57	Slide Takedown Lever Screw	2
AE-15	XAE H-UP Chamber-Right	1	AE-58	XAE Slide Takedown Lever Spring	1
AE-16	XAE H-UP Bucking	1	AE-59	XAE Frame	1
AE-17	XAE Inner Barrel	1	AE-59T	XAE Frame-TAN	1
AE-18	XAE H-UP Chamber-Left	2	AE-60	XAE Magazine Catch	1
AE-19	XAE H-UP Chamber Screw	1	AE-61	XAE Magazine Catch Spring	1
AE-20	XAE H-UP Plate	1	AE-62	XAE Backstrap-Thick	1
AE-21	H-UP Dial	1	AE-62T	XAE Backstrap-Thick-TAN	1
AE-22	O-ring	1	AE-63	XAE Backstrap-Thin	1
AE-23	XAE Recoil Spring	1	AE-63T	XAE Backstrap-Thin-TAN	1
AE-24	XAE Recoil Spring Guide	1	AE-64	XAE Magazine Nose	1
AE-25	XAE Trigger Housing	1	AE-66	XAE Magazine Nozzle Seal	1
AE-26	XAE Trigger	1	AE-67	XAE Magazine Lip	1
AE-27	XAE Trigger safety	1	AE-68	XAE Magazine Lip Pin	1
AE-28	Trigger Safety Pin	1	AE-69	XAE Magazine Follower	1
AE-29	XAE Trigger Bar	1	AE-70	XAE Magazine Follower Spring	1
AE-30	XAE Trigger Bar Spring	1	AE-71	XAE Magazine Base Plate Stop	1
AE-31	Trigger Bar Spring Pin	1	AE-72	Magazine Base Plate Stop Pin	1
AE-32	XAE Slide Catch Lever Plate	1	AE-73	XAE Magazine Gas Tube and Base	1
AE-33	Slide Catch Lever Plate Pin	2	AE-76	O-ring	1
AE-34	XAE Trigger Spring	1	AE-77	XAE Magazine Base	1
AE-35	XAE Trigger Safety Button	1	AE-78	XAE O-ring Pack	5
AE-36	XAE Slide Locking Plate Pin	1	AE-79	XAE Spring Pack	13
AE-37	V Trigger Housing Pin-Short	1	AE-80	XAE Cylinder Assembly	5
AE-38	XAE Slide Positioning Block	1	AE-81	XAE Magazine	1
AE-39	Slide Positioning Block Screw	1	AE-82	XAE Hammer Assembly	15
AE-40	XAE Hammer Housing-Left	1	AE-83	XAE Slide Disassemble Lever Screw-2	1
AE-41	XAE Knocker	1	AC-06A	REVO Energy Valve	1
AE-42	XAE Hammer	1	AC-08A	REVO Energy Nozzle	1