

## 1 APE 系列各部名稱 APE Series components



### ICS-231 Proline



### ICS-230 Proline



### IMT-230-1 Proline



### IMT-231-1 Proline



### IMD-230-1 Proline



### IMD-231-1 Proline



## 2 彈匣使用方式 Magazine attachment

### 2-1 裝BB彈方式 Load BBs

將彈匣上蓋依箭頭方向推開再倒入BB彈。  
Open the cover to load BBs.

建議使用 ICS 6mm BB彈  
ICS 6mm caliber BBs are recommended for optimum performance.



依箭頭方向旋緊彈匣底下旋鈕，即可將BB彈順利送出。  
To charge BB feed spring, please rotate the gear under the magazine.

### 2-2 裝卸彈匣 Magazine Loading and Unloading

直接將彈匣插入槍身彈匣插槽；推動彈匣釋放鈕以卸除彈匣。  
Directly insert magazine into magazine slot; unload the magazine by pressing the magazine catch button.



# 3

## 可動部的說明 Movable Parts

### 3-1 扳機護弓 Trigger Guard

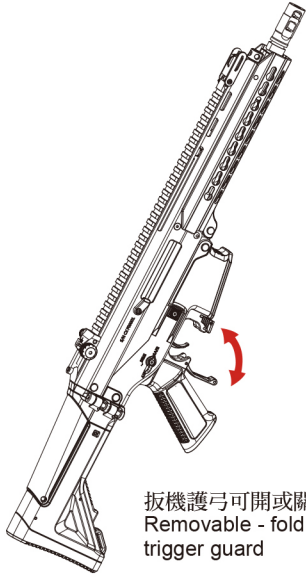

### 3-2 調整伸縮托長度及貼腮板高度 Adjust Retractable Stock Length

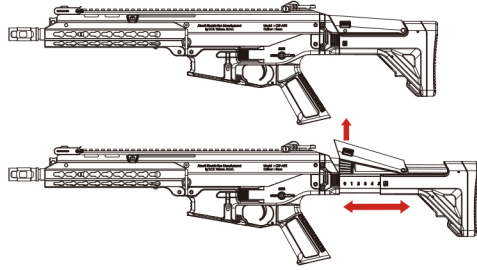

伸縮托可直接後拉作七段長度調整，要縮短時需按壓槍托套壓鈕進行調整。貼腮板可直接上拉作六段高度調整，要降低時需按壓貼腮板壓鈕進行調整。  
The retractable stock can be adjusted to 7 positions by pressing the stock button. The cheek rest can be adjusted to 6 positions by pressing the cheek rest button.

### 3-3 槍身結合 3 號齒正確位置圖 The correct position of sector gear before reassembling

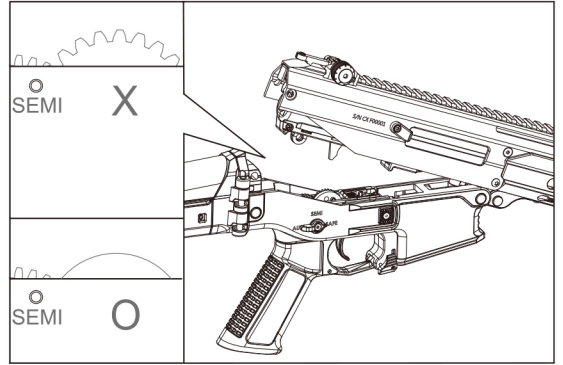

3號齒在槍身結合時，必須轉到正確位置，才可將上槍身蓋下。  
Make sure sector gear is turned to the correct position before reassembling the receiver/gearbox.

### 3-4 馬達間隙調整 Motor Gap Adjustment

使用4mm六角扳手來進行馬達傘齒間隙調整(出廠前已調整好)。  
Use the Allen key to make the fine-tune adjustment when needed.  
(Adjust when needed. Already made before out of factory)

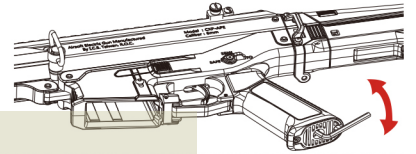

# 4

## 精確射擊調整動作 Precision Targeting Adjustment

### 4-1 準星高度調整 Front Sight Adjustment

使用準星板手順時針旋轉可降低準星高度  
使用準星板手逆時針旋轉可升高準星高度  
Rotate clockwise to lower the front sight  
by sight tool.  
Rotate counter-clockwise to raise the  
front sight by sight tool.

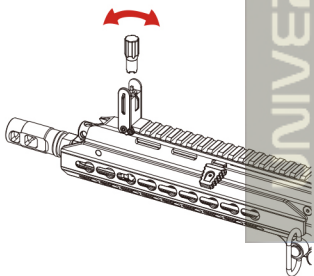

### 4-2 覘孔風偏調整 Rear Sight Adjustment

依旋鈕方向旋轉，  
則可將覘孔左、右調整  
Rotate clockwise to aim right  
Rotate counter-clockwise to aim left

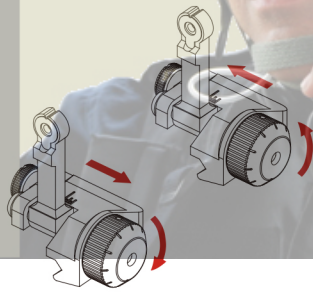

### 4-3 彈跳式準星/覘孔 Back-up Front Sight / Rear Sight

按壓準星壓鈕即可彈起準星座  
向前按壓準星座即可收合準星座  
Press the button to flip-up front sight.  
Push forward front sight to store.

向上推覘孔桿即可豎直覘孔  
向後推覘孔桿即可收合覘孔  
Pull up the stick to flip up rear sight.  
Push backward rear sight to store.

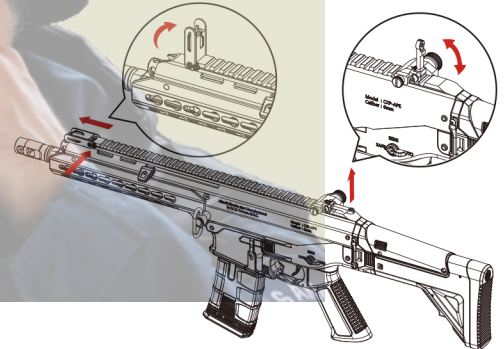

### 4-4 選擇射擊模式 Shooting Mode Setting

保險 Safety

單發 Semi Automatic

連發 Full Automatic

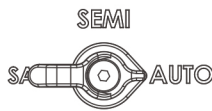
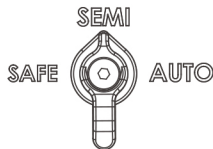
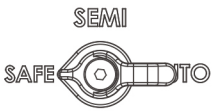

保險與止逆轉釋放同步

Switch the selector lever to safety position (aim forward) can release the spring and cease fire synchronously.

1. 槍枝使用完畢轉至單發狀態下發射2~3下後再關保險，可將活塞彈簧回覆至原處。
2. 槍身做分解時，必須先釋放活塞彈簧，才可做分解動作。
1. After playing, fire 2-3 by using semi automatic, then switch the selector lever to safety position to release the spring tension before storage.
2. Before disassembling the gear box, always release the spring by turning selector lever to safety position.

# 5

## 槍機飾片開合 Hop-up adjustment

1. 將槍機拉柄向後拉，槍機飾片即可固定在開啟狀態。
2. 將槍機釋放鈕向下壓，槍機飾片即可關閉。
1. Pull the charging handle backward to the end.  
The ejection cover can be locked to the rear.
2. Press the bolt catch to release charging handle.

Note: Do not put your finger or any foreign matter in the chamber when releasing charging handle.

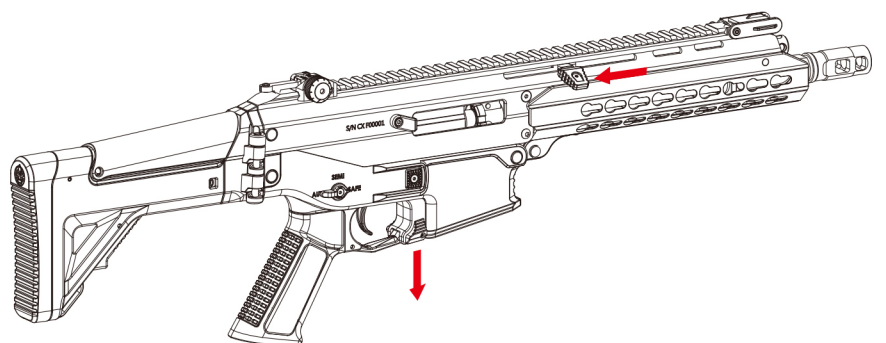

# 6

## H-UP彈道調整 H-UP adjustment

1. 調整撥盤向上使子彈下降  
1. Rotate the dial counter-clockwise to make the pellet go down.
2. 調整撥盤向下使子彈上升  
2. Rotate the dial clockwise to make the pellet go up.

防塵蓋  
Ejection Cover

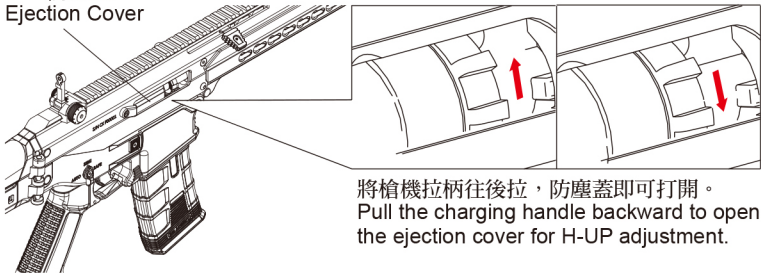

將槍機拉柄往後拉，防塵蓋即可打開。  
Pull the charging handle backward to open the ejection cover for H-UP adjustment.

H-UP調整：

子彈過於上飄，請調整撥盤向上旋轉。子彈過於下墜，請調整撥盤向下旋轉。BB彈呈現一直線的彈道才是正確射法。

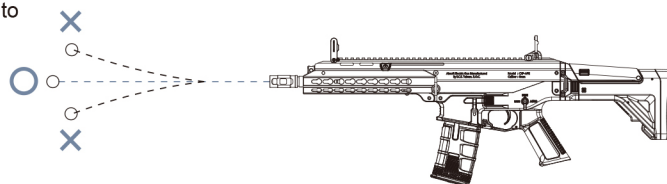

H-UP Adjustment:

When the BB pellet rises up, rotate the dial counter-clockwise to lower trajectory down. When the BB pellet falls down, rotate the dial clockwise to raise the trajectory up. Make sure the trajectory of BB pellet to be straight.

# 7

## 電池及護木的拆裝方法 Batteries and handguard installation

**注意** ※重新組裝時，必須依反向動作組合

Reassembling is the reverse of disassembling procedures.

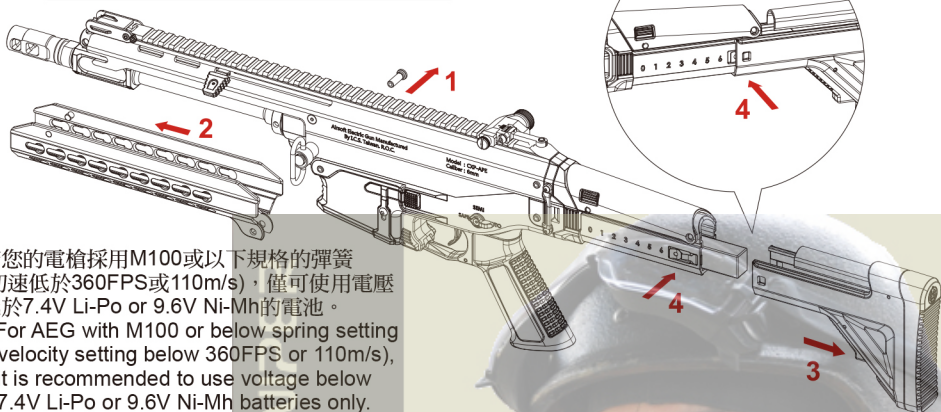

註：若您的電槍採用M100或以下規格的彈簧（初速低於360FPS或110m/s），僅可使用電壓低於7.4V Li-Po 或 9.6V Ni-Mh的電池。  
Note: For AEG with M100 or below spring setting (velocity setting below 360FPS or 110m/s), it is recommended to use voltage below 7.4V Li-Po or 9.6V Ni-Mh batteries only.

1. 取下護木插銷
  2. 將護木向前推即可拆下護木
  3. 按壓槍托套壓鈕向後拉
  4. 將槍托套固定鈕向內壓，即可將槍托套取下，進行電池拆裝
1. Remove the handguard pin
  2. Pull out the handguard
  3. Press the stock button and then pull the stock
  4. Press the stock spring to release the stock. Pull out the stock to install batteries.

# 8

## 齒輪箱拆解 Disassemble gearbox

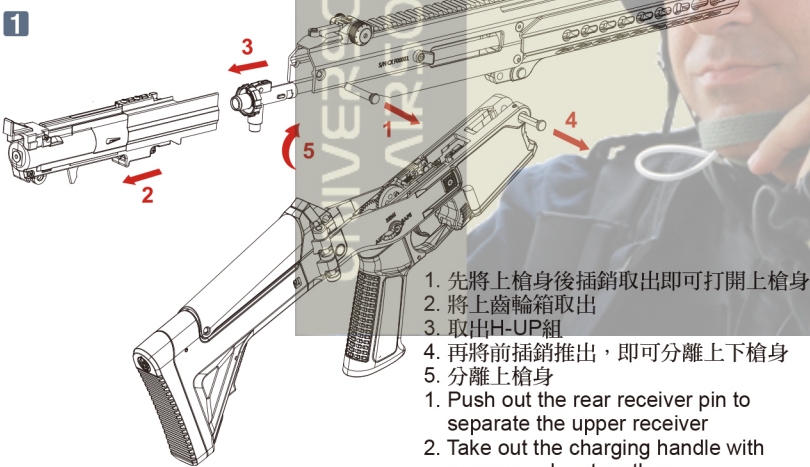

1. 先將上槍身後插銷取出即可打開上槍身
  2. 將上齒輪箱取出
  3. 取出H-UP組
  4. 再將前插銷推出，即可分離上下槍身
  5. 分離上槍身
1. Push out the rear receiver pin to separate the upper receiver
  2. Take out the charging handle with upper gearbox together
  3. Remove the H-UP set.
  4. Push out the front receiver pin
  5. Remove the upper receiver.

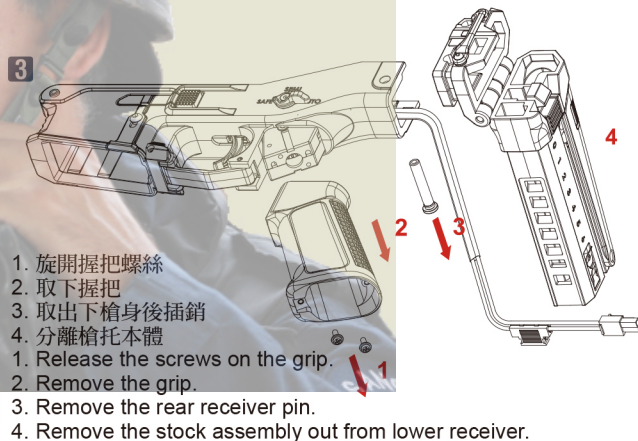

1. 旋開握把螺絲
  2. 取下握把
  3. 取出下槍身後插銷
  4. 分離槍托本體
1. Release the screws on the grip.
  2. Remove the grip.
  3. Remove the rear receiver pin.
  4. Remove the stock assembly out from lower receiver.

註：組回下槍身插銷時，需將電線下壓，再插入插銷，防止線材破損。  
Note: Before inserting back the rear receiver pin, please press down the wire gently and then insert the rear receiver pin to prevent damage to the wire.

# 2

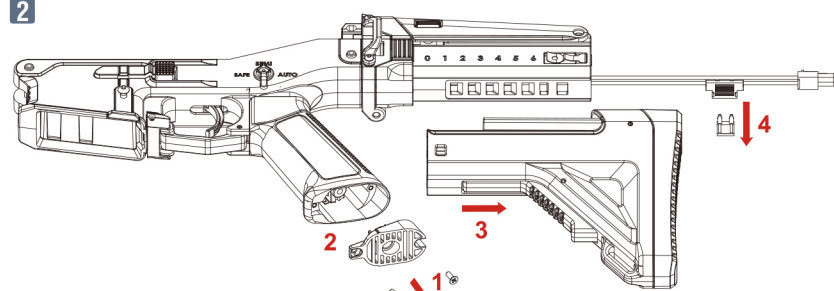

1. 旋開馬達底蓋螺絲
  2. 將馬達拆下
1. Release the screws on the motor plate
  2. Take the motor out
3. 取下槍托（參考步驟7）
  4. 取下保險絲
3. Remove the rubber butt plate (refer to step.7)
  4. Remove the fuse

# 4

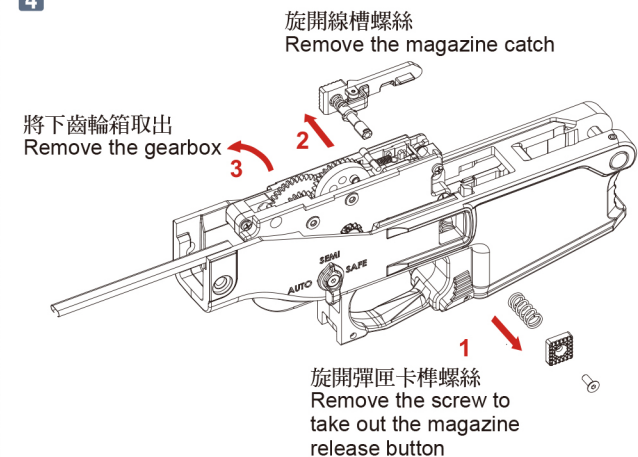

4. 旋開線槽螺絲  
Remove the magazine catch
- 將下齒輪箱取出  
Remove the gearbox
- 旋開彈匣卡榫螺絲  
Remove the screw to take out the magazine release button

## 9

## 各部零件說明 Description

\*每一款槍型基本配備不同依實際出貨為主。圖片僅供參考。  
The components/accessories for each model may have kind of differences depending on the actual goods. Images are only for reference.

### ICS-230 Proline



Patents acquired: US 7,077,117 B1 / US D706,880 S / RCD 002509737-0001 / R.O.C. M244431 / R.O.C. M320468 / R.O.C. D159178 / US D733,233S / EM002246579-0001

### WARNING 警告 電槍使用之注意事項 Maintenance

- 請勿使用回收及劣質的 BB 彈，以減少槍管損耗與避免卡彈的情形發生。
  - 如發現有卡彈的情形，應立即停止射擊，如卡彈後再勉強射擊，則會增加齒輪損耗。請使用內附通槍條，將卡彈清除後才可繼續使用。若完成通槍基本故障排除後仍無法使用時，請回原採購店家或專業經銷商尋求維修服務。
  - 使用前請先確定您的電池已充滿電，當使用中發覺電池即將用盡或射擊速度降低時，應立即更換電池。
  - 請定期使用通槍條清潔槍管，以保持槍支射擊時的準確性及減少卡彈的情形發生。
  - 請勿經常空槍射擊，以減少BOX及齒輪不必要的損耗。
- 使用前請務必詳閱此說明書限18歲以上使用  
Always read through this manual before operation.  
User restricted to 18 years of age or older.
- Do not use recycle or low quality BB pellets to reduce the barrel damage and prevent from jams.
  - When a BB pellet is jammed, cease fire immediately. Firing under jam may cause damage on gears. Please use the cleaning rod that came with your airsoft gun to push it into the barrel by moving down gently until the jammed BB pellet comes out. If the jam still cannot be solved, please contact your original purchase retailer or ask for professional agent for repair service.  
Note: No need to remove the barrel when eliminating jam.
  - Please make sure the battery is fully charged before using. When the battery is run out or firing speed is decreasing, new battery has to be replaced immediately.
  - Please use cleaning rod periodically to clean the barrel to ensure the firing precision and reduce jam.
  - Do not dry fire the airsoft gun at any time to reduce damage to the gearbox.



WWW.ICSBBS.COM