

8 各部零件說明 Description

ICS-271 Proline

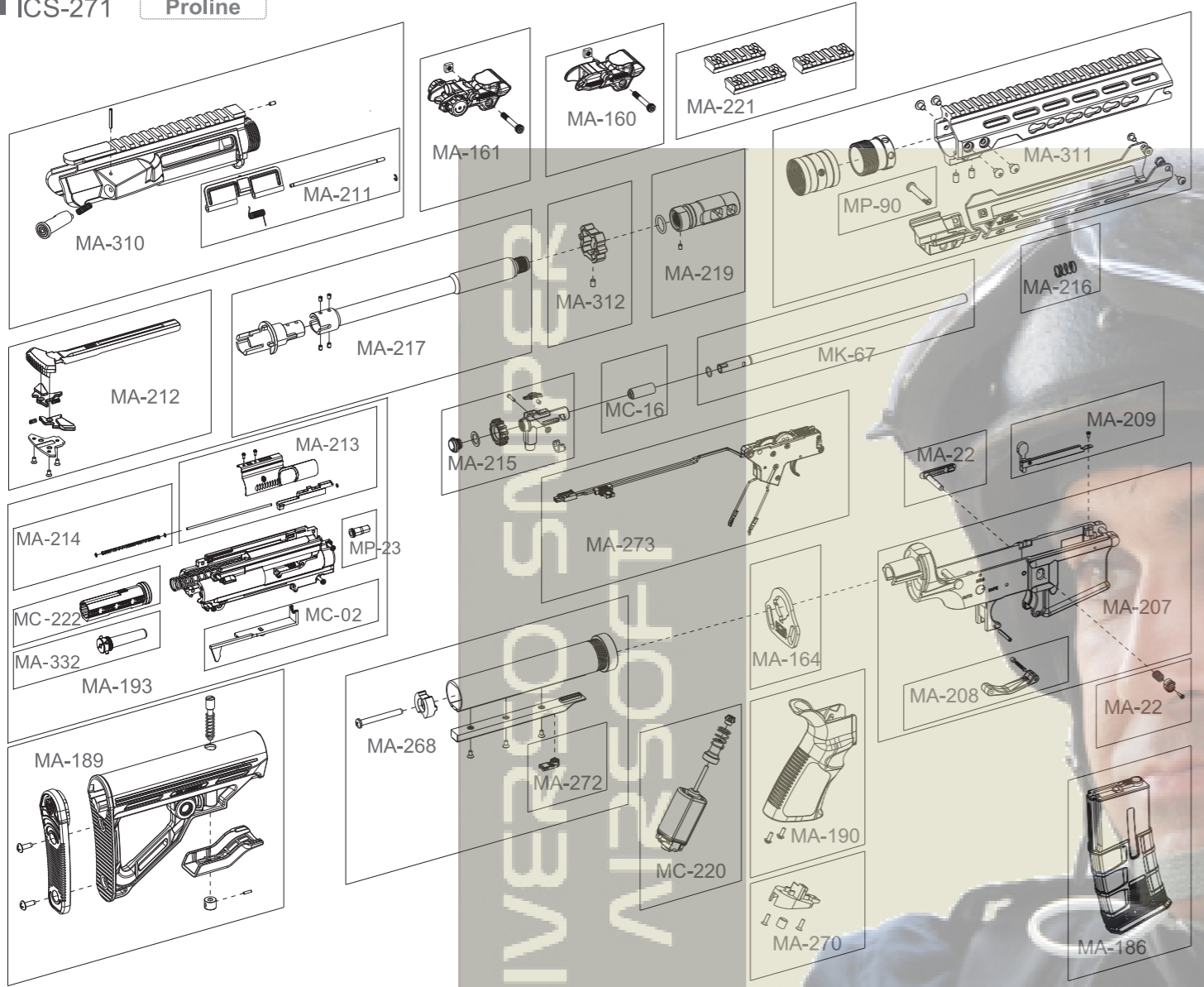

Patents acquired: US 7,077,117 B1 / US D706,879 S / US D706,880 S / R.O.C. M244431 / R.O.C. M320468 / R.O.C. D160112 / R.O.C. D159178 / EM002246579-0001

WARNING 警告 電槍使用之注意事項 Maintenance

- 請勿使用回收及劣質的 BB 彈，以減少槍管損耗與避免卡彈的情形發生。
- 如發現有卡彈的情形，應立即停止射擊，如卡彈後再勉強射擊，則會增加齒輪損耗。請使用內附通槍條，將卡彈清除後才可繼續使用。若完成通槍基本故障排除後仍無法使用時，請回原採購店家或專業經銷商尋求維修服務。
- 使用前請先確定您的電池已充滿電，當使用中發覺電池即將用盡或射擊速度降低時，應立即更換電池。
- 請定期使用通槍條清潔槍管，以保持槍管射擊時的準確性及減少卡彈的情形發生。
- 請勿經常空槍射擊，以減少BOX及齒輪不必要的損耗。
- 不使用本產品時請移除電池，以避免誤觸擊發。
- 請依原廠附贈之保險絲規格使用，不當配置可能導致零件故障，槍內配置M100彈簧時請使用20A保險絲，M120彈簧時請使用25A保險絲。使用前請務必詳閱此說明書限18歲以上使用。Always read through this manual before operation. User restricted to 18 years of age or older.



www.icsbb.com

1 HOG系列各部名稱 HOG Series components

ICS-271 Proline

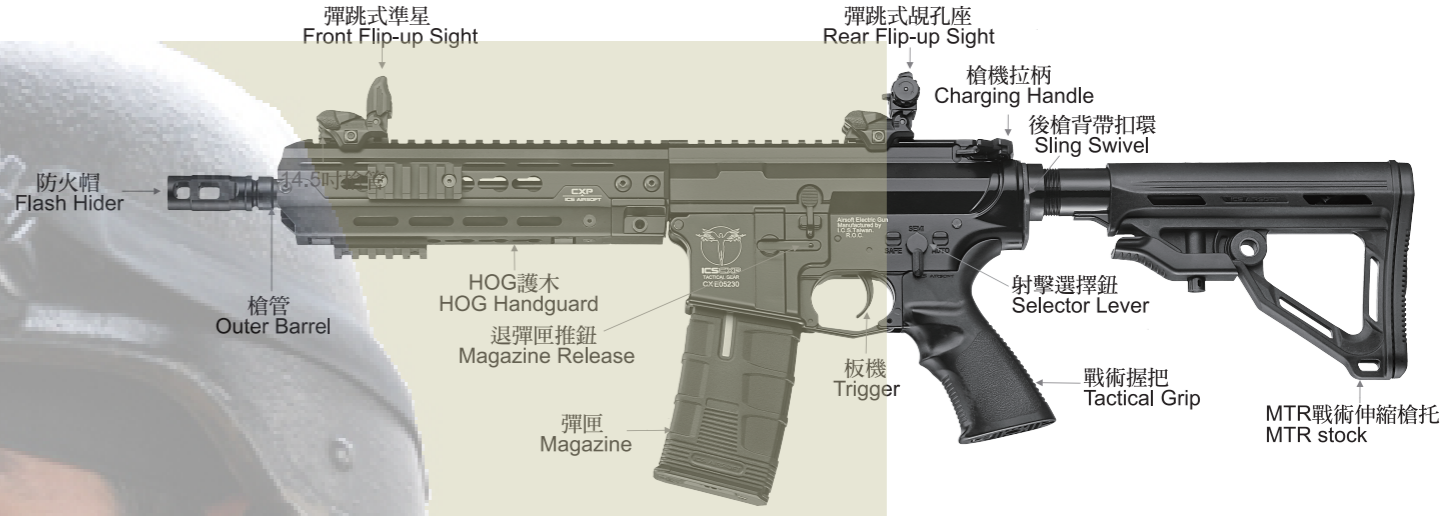

IMT-271-1 Proline

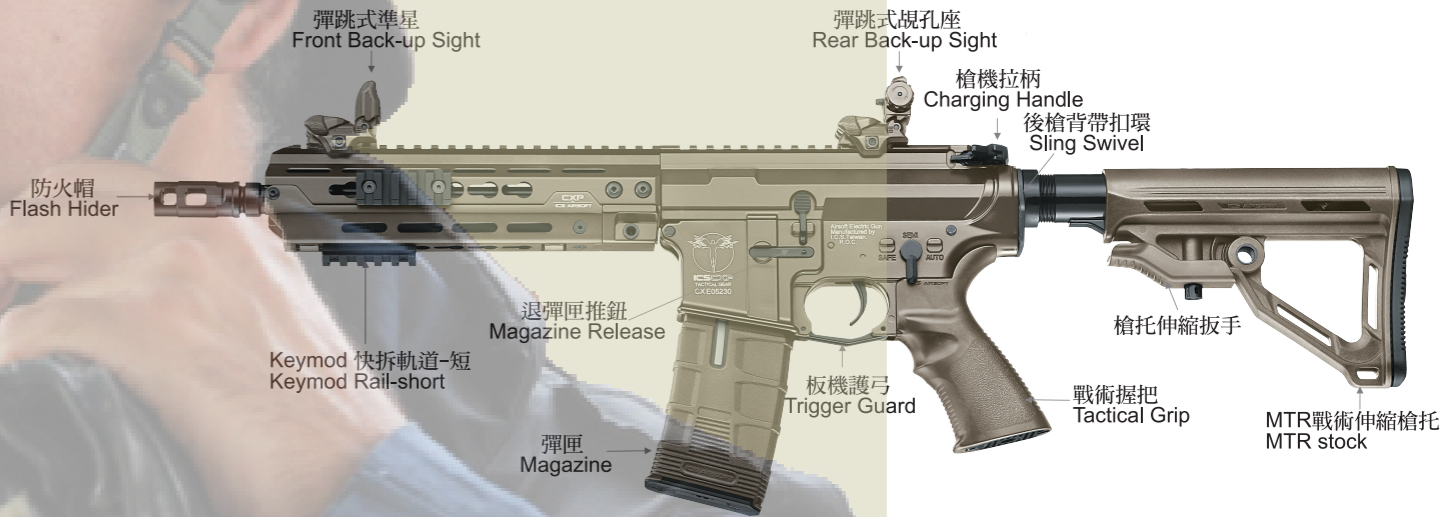

2 彈匣使用方式 Magazine attachment

2-1 裝BB彈方式 Load BBs

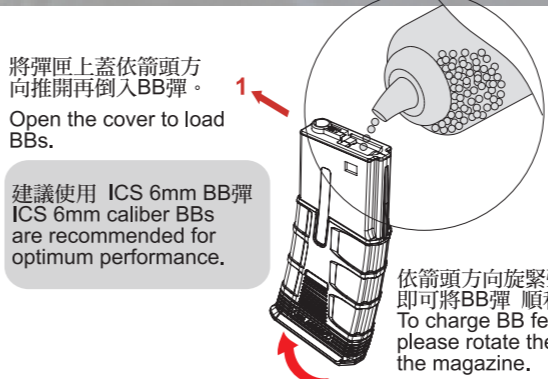

2-2 裝卸彈匣 Magazine Loading and Unloading



3 可動部的說明 Movable parts

3-1 扳機護弓 Trigger Guard

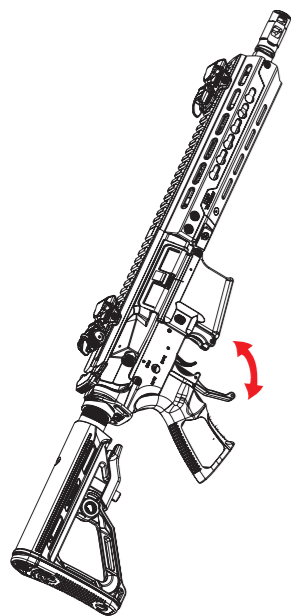

扳機護弓可開或關
Removable - folding
trigger guard

3-2 槍身結合 3 號齒正確位置圖 The correct position of sector gear before reassembling

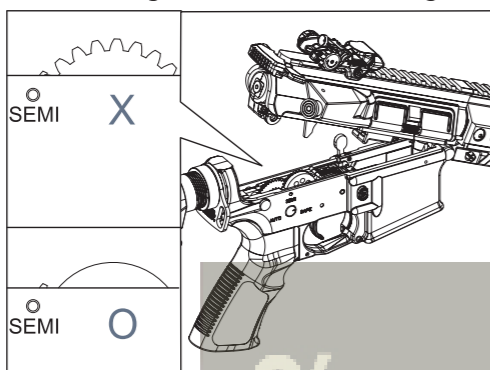

3號齒在槍身結合時，必須轉到正確位置，才可將上槍身蓋下。
Make sure sector gear is turned to the correct position before reassembling the receiver/gearbox.

3-4 馬達間隙調整 Motor Gap Adjustment

使用4mm六角扳手來進行馬達傘齒間隙調整(出廠前已調整好)。
Use the Allen key to make the fine-tune adjustment when needed. (Adjust when needed. Already made before out of factory)

3-3 調整伸縮托長度 Adjust Retractable Stock Length

注意：依所選購的 Li-Po 電池大小，將托桿膠塊安裝於A或B，以免托桿作動時損傷電池。

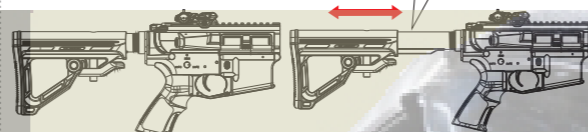
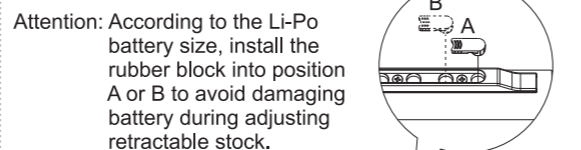

按下卡榫，即可將伸縮托向後拉或向前推，共有4~5段可供調整長度。
Press and hold the stock release lever to unlock. Adjust the 4~5 position retractable stock to the most comfortable position.

5 H-UP彈道調整 H-UP Adjustment

- 調整撥盤向上使子彈下降
1. Rotate the dial counter-clockwise to make the pellet go down.
- 調整撥盤向下使子彈上升
2. Rotate the dial clockwise to make the pellet go up.

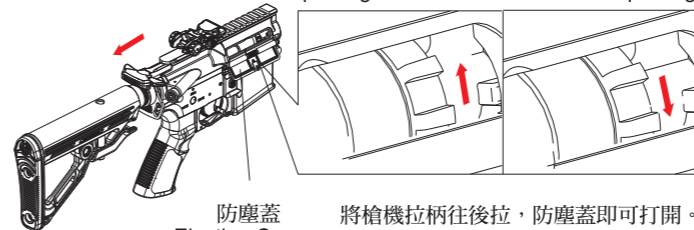

防塵蓋 將槍機拉柄往後拉，防塵蓋即可打開。
Ejection Cover Pull the charging handle backward to open the ejection cover for H-UP adjustment.

H-UP調整：
子彈過於上飄，請調整撥盤向上旋轉。子彈過於下墜，請調整撥盤向下旋轉。BB彈呈現一直線的彈道才是正確射法。

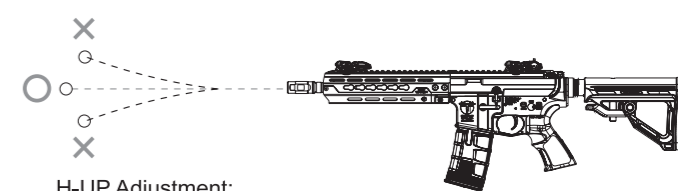

H-UP Adjustment:
When the BB pellet rises up, rotate the dial counter-clockwise to lower trajectory down. When the BB pellet falls down, rotate the dial clockwise to raise the trajectory up. Make sure the trajectory of BB pellet to be straight.

6 電池及護木的拆裝方法 Batteries and handguard installation

注意 重新組裝時，必須依反向動作組合
Reassembling is the reverse of disassembling procedures.

註：若您的電槍採用M100或以下規格的彈簧(初速低於360FPS或110m/s)，僅可使用電壓低於7.4V Li-Po 或 9.6V Ni-Mh的電池。
Note: For AEG with M100 or below spring setting (velocity setting below 360FPS or 110m/s), it is recommended to use voltage below 7.4V Li-Po or 9.6V Ni-Mh batteries only.

- 取出槍托即可安裝電池
- 取出護木插銷
- 下護木向下旋開取出
- 將六顆螺絲拆下
- 上護木往前取出

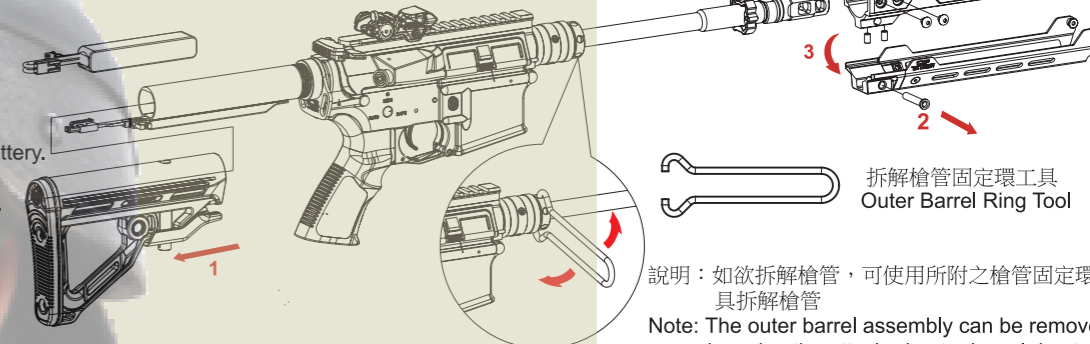

拆解槍管固定環工具
Outer Barrel Ring Tool

說明：如欲拆解槍管，可使用所附之槍管固定環工具拆解槍管
Note: The outer barrel assembly can be removed by using the attached outer barrel ring tool.

4 調整規孔準星 Sights adjustment

4-1 規孔調整方式 Rear Sight Adjustment

A: 精密射擊調整 Precision Targeting Adjustment

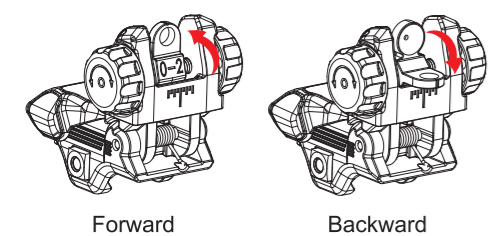

Forward Backward

近距將規孔往前推/遠距將規孔往後推
Common/close-range low-light shooting
Push forward to engage battle sight
Precision daylight shooting
Push backward to engage peep hole

B: 規孔調整方式 Rear Sight Adjustment

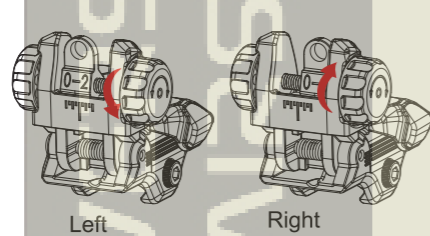

Left Right

依旋鈕方向旋轉即可將規孔組左右調整
Rotate clockwise to aim right
Rotate counter clockwise to aim left

4-2 前準星調整 Front Sight Adjustment

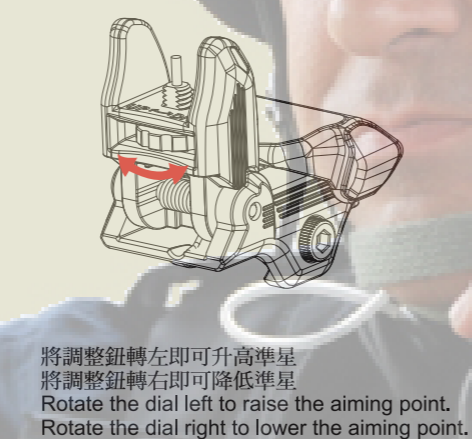

將調整鈕轉左即可升高準星
將調整鈕轉右即可降低準星
Rotate the dial left to raise the aiming point.
Rotate the dial right to lower the aiming point.

7 齒輪箱拆解 Disassemble gearbox

- 先將槍身後結合銷推出即可打開上槍身
- 拉柄連同上BOX一同取出
- 取出H-UP組
- 再將槍身前結合銷推出
- 取出上槍身
- 將槍托調整桿向下拉開後取出槍托

1. Push out the rear receiver pin to separate the upper receiver
2. Take out the charging handle with upper gearbox together
3. Remove the H-UP set
4. Push out the front receiver pin
5. Remove the upper receiver
6. Pull the stock release lever then pull out the stock

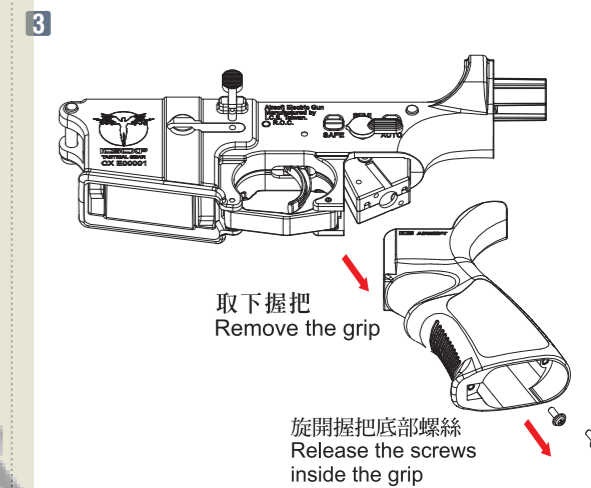

取下握把
Remove the grip

旋開握把底部螺絲
Release the screws inside the grip

4-3 選擇射擊模式 Shooting Mode Setting

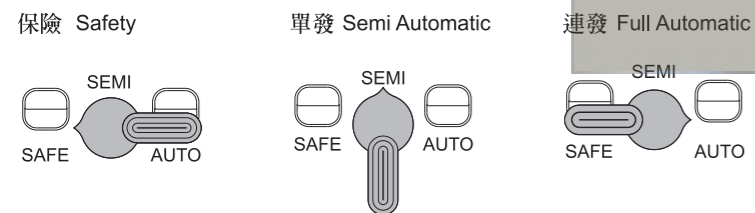

Switch the selector lever to safety position (aim forward) can release the spring and cease fire synchronously.

1. 槍枝使用完畢轉至單發狀態下發射2~3下後再關保險，可將活塞彈簧回覆至原處。
2. 槍身做分解時，必須先釋放活塞彈簧，才可做分解動作。

1. After playing, fire 2-3 by using semi automatic, then switch the selector lever to safety position to release the spring tension before storage.
2. Before disassembling the gearbox, always release the spring by turning selector lever to safety position.

4-4 彈跳式準星/規孔 Back-up Front Sight / Rear Sight

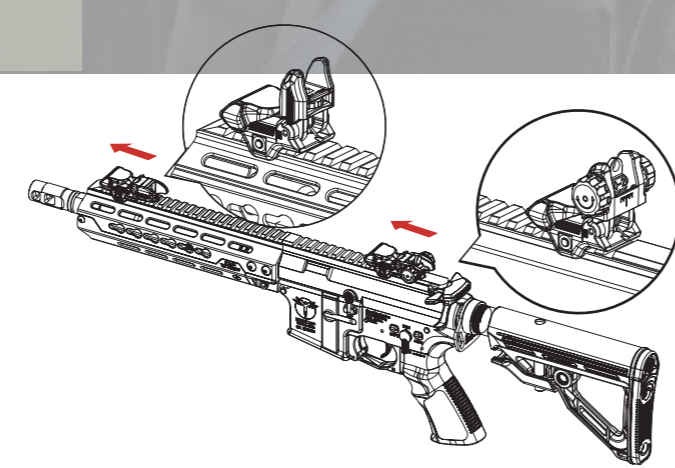

1. 旋開馬達底蓋螺絲
2. 將馬達拆下
3. 取下保險絲
4. 取下托桿膠塊
5. 拆解托桿上蓋螺絲
6. 拆解槍托固定桿螺絲取下托桿

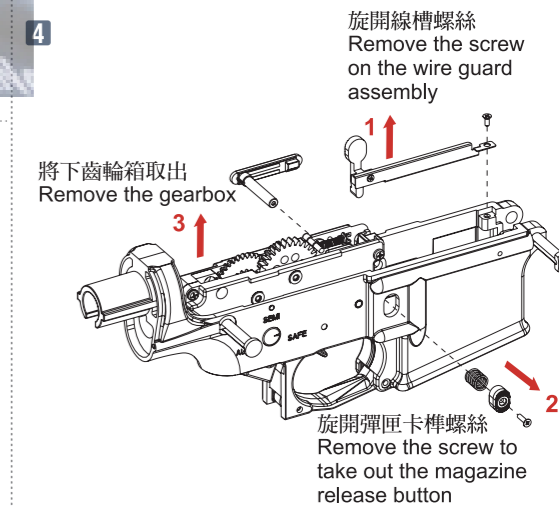

將下齒輪箱取出
Remove the gearbox

旋開線槽螺絲
Remove the screw on the wire guard assembly

旋開彈匣卡榫螺絲
Remove the screw to take out the magazine release button