

*每一款槍型基本配備不同依實際出貨為主。圖片僅供參考。
The components/accessories for each model may have kind of differences depending on the actual goods. Images are only for reference.

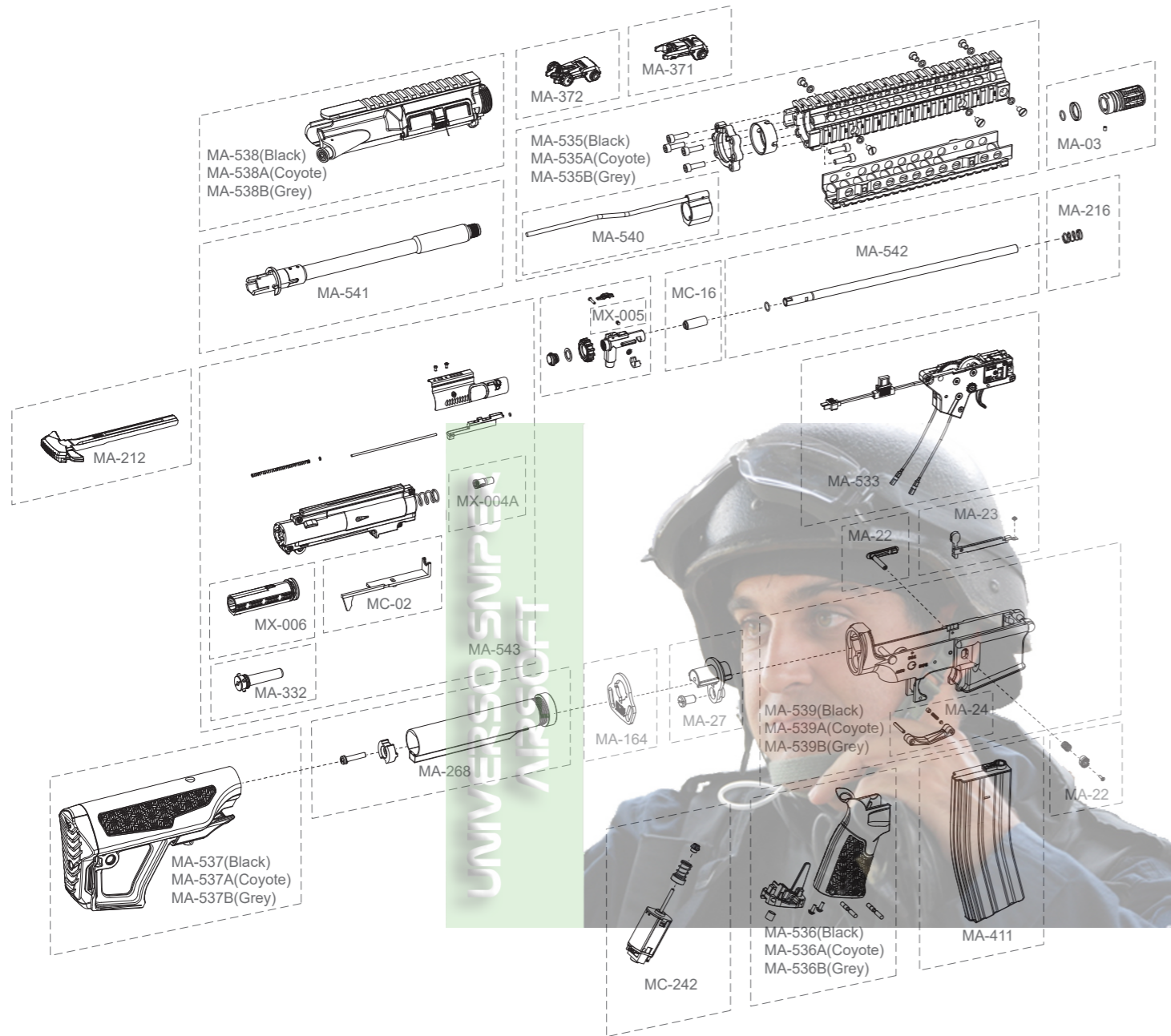

1 各部名稱 Series Component

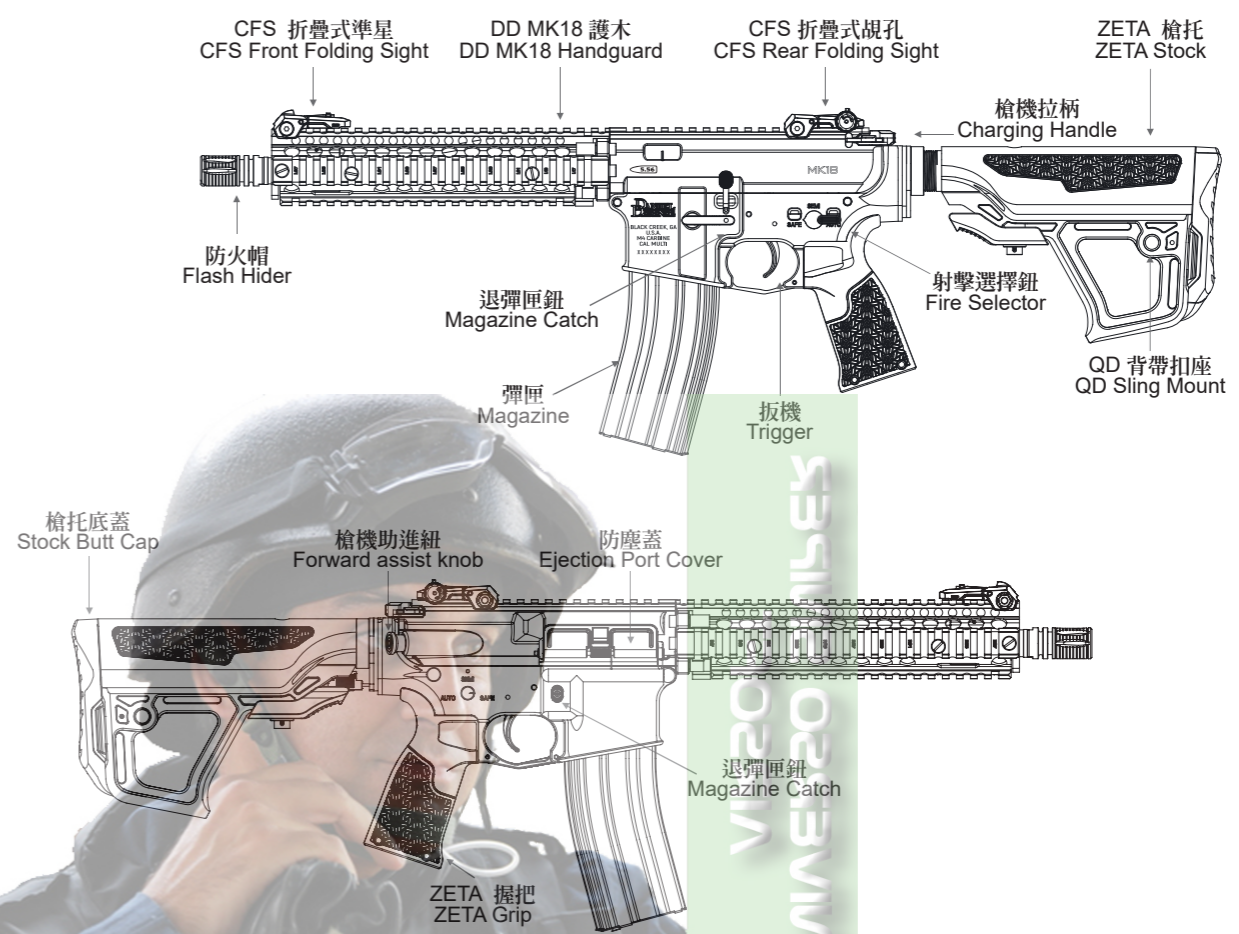

相關系列產品型號與詳細規格，請以官方網站公布為主。
For related series product models and detailed specifications, please refer to the official website.

2 彈匣使用方式 Magazine Attachment

2-1 裝BB彈方式 Load BBs

將BB彈填入彈匣。
Load BBs.

建議使用 6mm BB彈。
6mm caliber BBs are recommended for optimum performance.

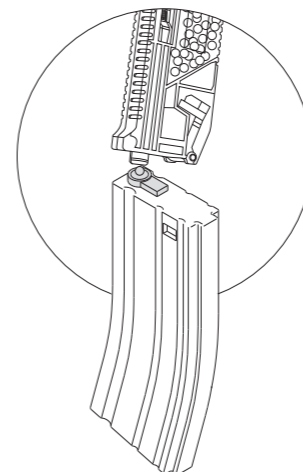

2-2 裝卸彈匣 Magazine Loading and Unloading

1. 直接將彈匣插入彈匣插槽。
2. 按壓退彈匣鈕即可將彈匣卸下。



WARNING 警告 電槍使用之注意事項 Maintenance

1. 請勿使用劣質或回收BB彈，以減少槍管損耗及避免卡彈。
2. 一旦發生卡彈或射擊速度降低時，應立即停止射擊，以避免齒輪過度耗損。請使用通槍條將殘彈清除，或被測電池電量後方可繼續使用。
3. 不使用本產品時，請務必將射擊選擇鈕置於保險(S)的位置上，將電池移除並定期使用通槍條清潔槍管。
4. 請依照原廠附贈之保險絲規格使用。不當配置可能導致零件故障，槍內配置M100彈簧請用20A保險絲，M120彈簧請用25A保險絲。
5. 彈頭直徑6mm。其槍口動能為二焦耳以下、射程範圍為50公尺以內。
6. 適用年齡為18歲以上。
7. 使用本商品不得改造或變造，並不得使用金屬彈頭。
8. 「此槍非玩具」，濫用可能導致嚴重傷害，尤其是眼睛。使用時應確保本身及射程範圍內所有人員均已確實穿戴護目鏡。
9. 使用方法及注意事項請詳閱說明書內容。
10. 建議使用以下電池以達到最大效益：
SSS系統建議使用7.4v & 11.1v Li-Po電池。
傳統電閘與FET電閘系統11.1v Li-Po電池Ready。
※使用非建議電池可能會造成產品效能低落、功能異常甚至損毀。
(原產地：台灣 / 製造商：一芝軒企業有限公司 / 地址：台中市神岡區東洲路79巷67號 / 電話：04-25256461)

1. To reduce the abrasion of inner barrel and to avoid BB jam, please do not use inferior or reused BB pellets.
2. If your gun is jammed or the muzzle velocity has decreased, please stop shooting immediately in case the gear abrades excessively. Use the clearing rod to clear out the remaining pellets, or check your battery power before continue using your gun.
3. Please engage the safety, dismount the battery and clear the inner barrel with the clearing rod periodically when not using this product.
4. Please use the same fuse specification as the original one. Equipping improper fuse might cause malfunction to the components. Apply 20A fuse if the gun using a M100 spring; apply 25A fuse if using M120 spring.
5. The diameter of the BB pellet is 6mm. The muzzle energy is less than two joules, and the shooting range is within 50 meters.
6. The recommended age to operate this product is 18 years old and above.
7. Modify, reform, and using metal bullets on this product are strictly forbidden.
8. This is NOT a toy. Abusing might cause severe injuries, especially to the eyes. Before operating, please make sure that every personnel in the shooting range have worn eye protections properly, including the operator.
9. Please read the manual for instruction and precaution.
10. In order to achieve the maximum performance, the following batteries are recommended:
SSS system: 7.4v or 11.1v Li-Po batteries.
Traditional switch and FET switch system: 11.1v Li-Po battery Ready.
※Using non-recommended batteries may cause poor performance, abnormal functions or even damage to the product.
Origin: Taiwan/ Manufacturer: ICS enterprise Co., Ltd / Address: No.67, Ln. 79, Dongzhou Rd., Shengang Dist., Taichung City 429, Taiwan / TEL : (+886) 4-2525-6461



3 可動部的說明 Movable Parts

3-1 槍身結合3號齒正確位置圖 The correct position of sector gear before reassembling

注意 未進行歸位校正，會損壞活塞及齒輪
*The piston and gear may be damaged without correcting the position in advance.

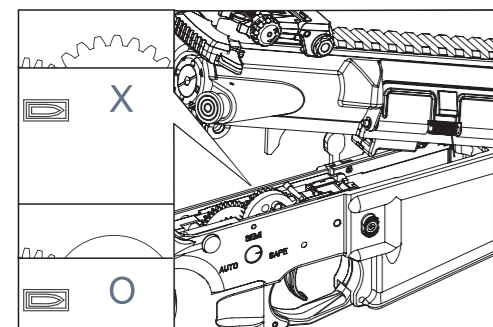

3號齒在槍身結合時，必須轉到正確位置，才可將上槍身蓋下。
Make sure the sector gear is turned to the correct position before reassembling the receiver/gearbox.

4 精確射擊調整動作 Precision Targeting Adjustment

4-1 準星規孔調整方式 Front and Rear Sight Adjustment

A: 開合準星規孔 Rear and Front sights usage

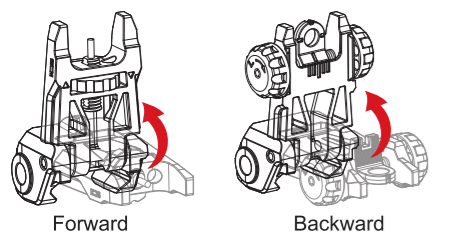

準星規孔立起或收合皆可瞄準
You can aim with the Front and Rear sight either raised or folded.

B: 規孔調整方式 Rear sight adjustment

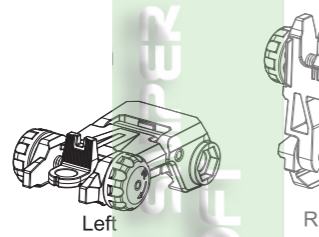

依旋轉方向旋轉即可將規孔組左右調整
Rotate clockwise to aim right.
Rotate counter clockwise to aim left.

C: 準星高度調整 Front sight adjustment



將調整扭轉左即可升高準星；
將調整扭轉右即可降低準星。
Rotate the dial counterclockwise to raise the aiming point.
Rotate clockwise to lower the aiming point.

4-2 選擇射擊模式 Shooting Mode Setting

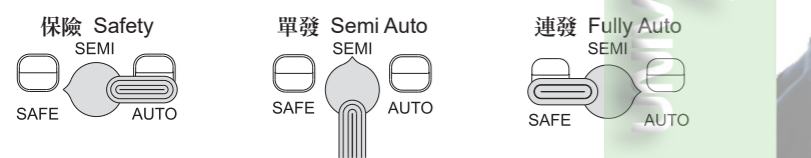

*此系列產品具備「關保險自動釋放彈簧功能」。
1. 槍上有彈匣的情況下，關保險會自動釋放彈簧，有機率造成第一發雙彈射出或者小硬彈，屬正常情況。
2. 槍枝使用完畢，請轉至單發模式下，擊發2-3下後做清槍動作，再關保險確保槍管內已無殘彈。
3. 上下槍身分解前，務必先關保險釋放彈簧，避免造成齒輪倒轉損壞活塞。
*關保險自動釋放，可延長彈簧壽命，避免長期擠壓造成疲乏

5 H-UP 彈道調整 H-UP Adjustment

注意 非必要時，手指請勿放置於H-UP調整處，避免受傷
*To avoid injuries, only put your finger on the H-up adjustment when necessary.

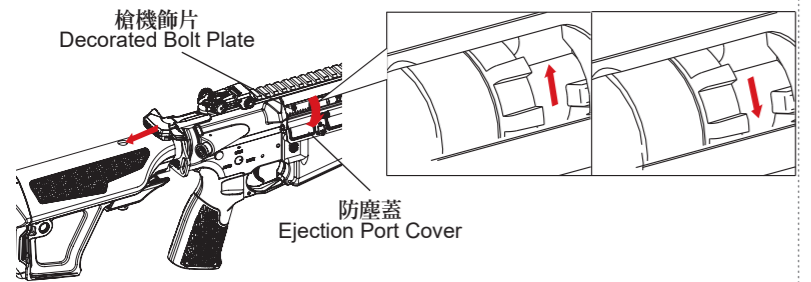

1. 將槍機拉柄往後拉(不可放開)，防塵蓋下翻、槍機飾片向後打開，即可進行彈道調整。
2. 視彈道進行撥盤調整，調整完即可放開槍機拉柄。
1. To adjust the trajectory, pull and hold the charging handle to the end (do not release) to open the ejection port cover downward, and open the decorated bolt plate backward.
2. Rotate the dial to adjust the trajectory. Release the charging handle once you finished the adjustment.

3-2 快拆尾頂桿 QD Spring Guide

1. 使用4mm六角板手，對準尾頂桿往內推入後旋轉45度
2. 將尾頂桿與彈簧抽出
*安裝彈簧後依照步驟1倒序組裝

1. Use 4mm Allen key, insert it to the spring guide and then press down to turn 45 degrees.
2. Take out the spring guide and spring.
* Reverse the above steps to install spring.

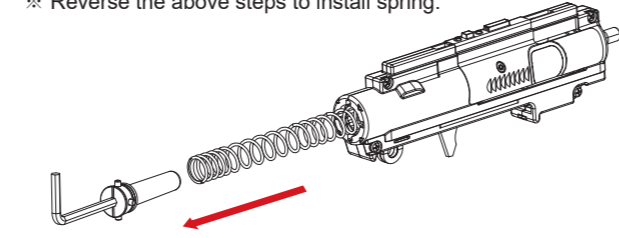

6 電池及護木的拆裝方法 Disassembling for Battery and Handguard

注意 重新組裝時，必須依反向動做組合。
* Reassembling is the reverse of disassembling procedures.

6-1 護木拆裝方式 Disassembling the handguard

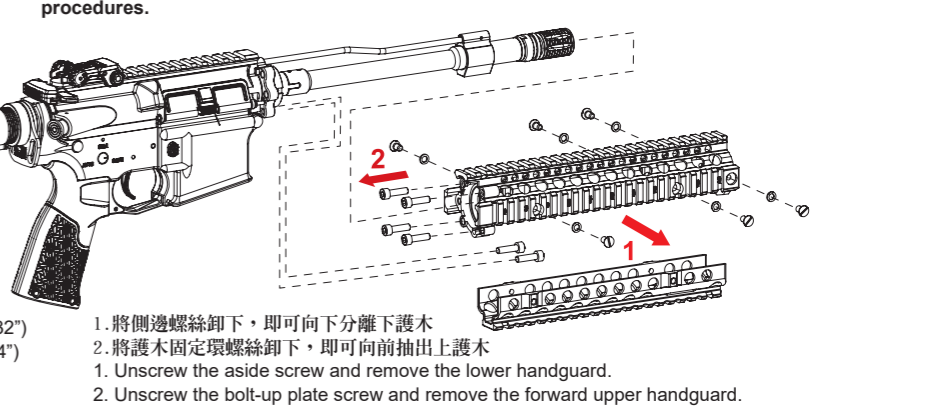
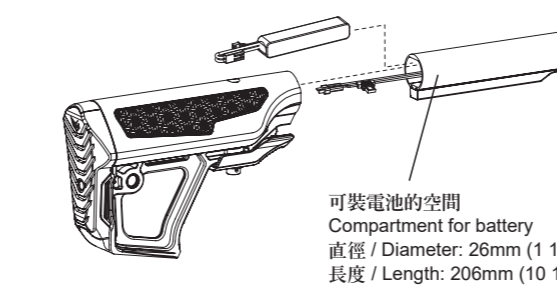

可裝電池的空間
Compartment for battery
直徑 / Diameter: 26mm (1 1/32")
長度 / Length: 206mm (10 1/4")
1. 將側邊螺絲卸下，即可向下分離下護木
2. 將護木固定環螺絲卸下，即可向前抽出上護木
1. Unscrew the aside screw and remove the lower handguard.
2. Unscrew the bolt-up plate screw and remove the forward upper handguard.

6-2 電池裝卸方式 Loading the battery

1. 抓持於槍托底板的兩側，先向後拉動將底板與槍托本體脫離。
2. 將槍托底蓋旋轉左或右45度後放開，即可安裝電池。
Pull the butt-stock aside backward and turn it to 45 degrees. The battery can be loaded.

將槍托調整桿往下拉並轉向側邊，即可向後取下槍托。
Pull the stock adjustment lever downward and turn it aside. After you can remove the stock backward.

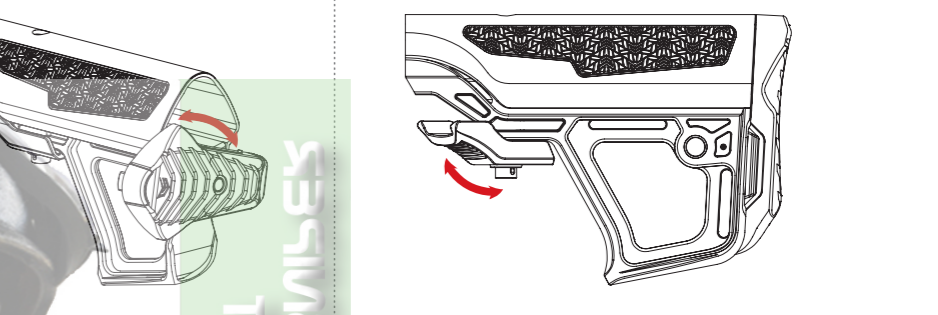
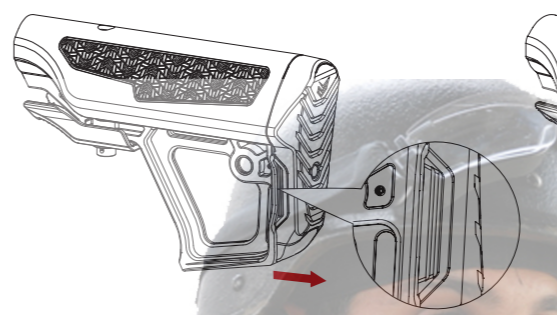

7 齒輪箱拆解 Disassemble Gearbox

注意 先卸彈匣跟電池，再進行拆解
*Unload the magazine and battery before you proceed to disassemble.

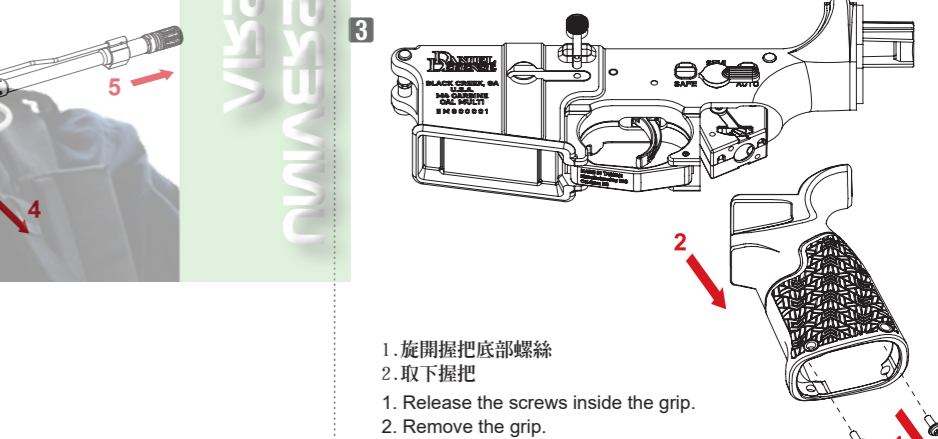
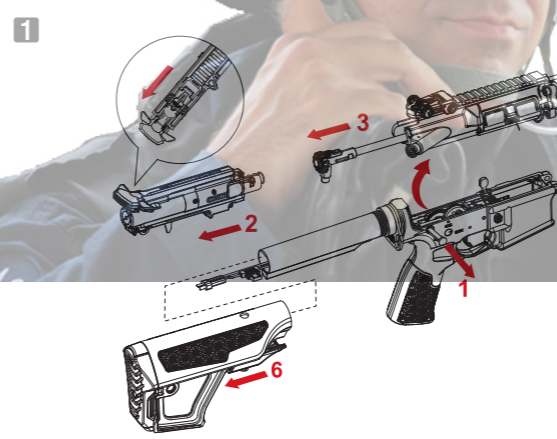

1. 先將槍身後結合銷推出即可打開上槍身
2. 拉柄連同齒輪箱一同取出
3. 取出H-UP組
4. 再將槍身前結合銷推出
5. 取出上槍身
6. 將槍托調整桿往下拉並轉向側邊，向後取下槍托

1. 旋開握把底部螺絲
2. 取下握把
1. Release the screws inside the grip.
2. Remove the grip.
1. Push out the rear receiver pin to open the upper receiver.
2. Take out the charging handle with upper gearbox together.
3. Take out the H-UP set.
4. Push out the front receiver pin.
5. Separate the upper receiver.
6. Pull the stock adjustment lever downward and turn it aside. Remove backward the stock.

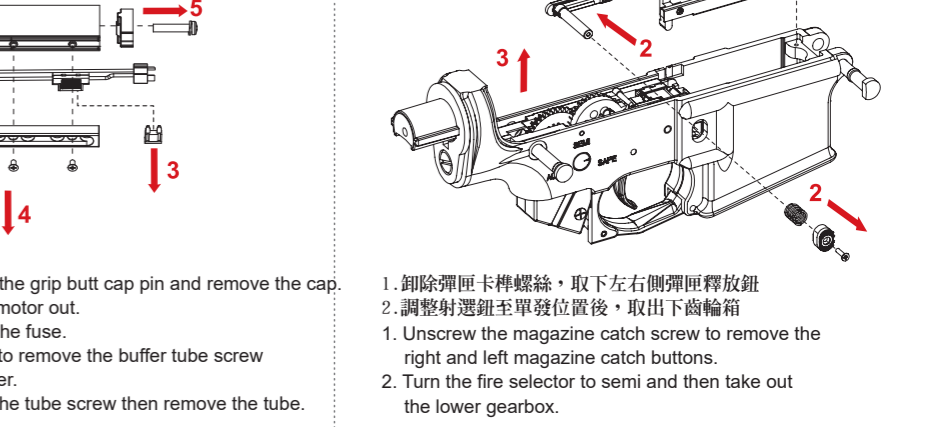
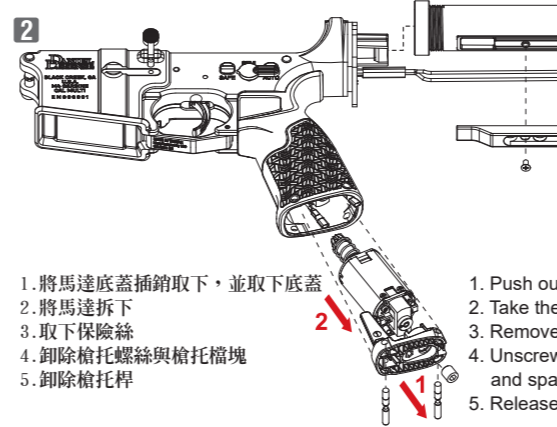

1. 將馬達底蓋插銷取下，並取下底蓋
2. 將馬達拆下
3. 取下保險絲
4. 卸除槍托螺絲與槍托檔塊
5. 卸除槍托桿

1. 卸除彈匣卡榫螺絲，取下左右側彈匣釋放鈕
2. 調整射選鈕至單發位置後，取出下齒輪箱
1. Unscrew the magazine catch screw to remove the right and left magazine catch buttons.
2. Turn the fire selector to semi and then take out the lower gearbox.
1. Push out the grip butt cap pin and remove the cap.
2. Take the motor out.
3. Remove the fuse.
4. Unscrew to remove the buffer tube screw and spacer.
5. Release the tube screw then remove the tube.

H-UP調整：BB彈呈現一直線的彈道才是正確射法。
過於上飄：將撥盤向上旋轉。
過於下墜：將撥盤向下旋轉。
H-up Adjustment: Make sure the trajectory of the BB pellets to be straight.
When the BB pellet flies up: Rotate the dial counter-clockwise to lower the trajectory.
When the BB pellet falls down: Rotate the dial clockwise to raise the trajectory.