

KJWORKS
M200 SERIES
MANUAL

UNIVERSAL SNIPER
AIRSOFT

WARNING: BEFORE USAGE, THE INSTRUCTION MUST BE READ.

THANK YOU FOR PURCHASING. THE FOLLOWING ATTENTION POINTS AND INSTRUCTIONS MUST BE READ. SHOOTING WITHOUT CAUTION OR USED IMPROPERLY, BLINDNESS OR INJURIES COULD BE LEAD.

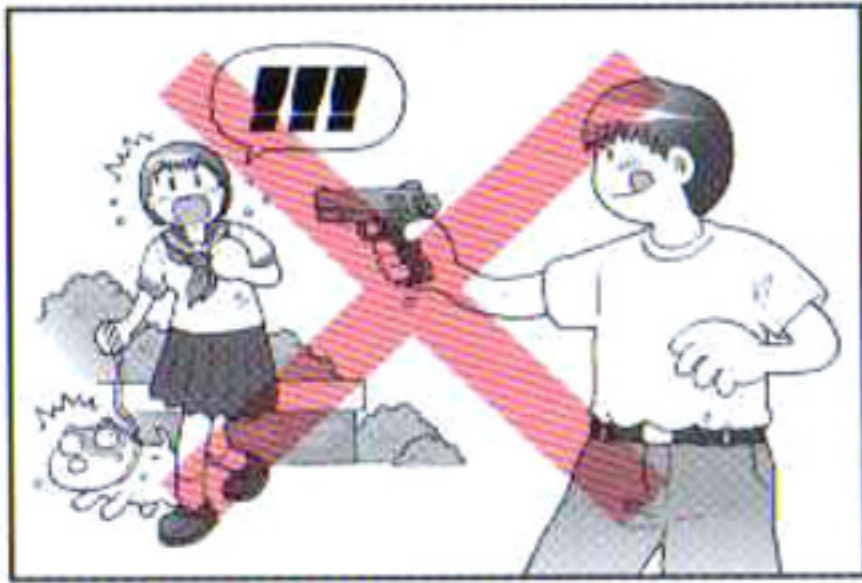

DO NOT POINT AT PEOPLE OR ANIMAL.



BE CAREFULL WHAT TARGET YOU SHOOT

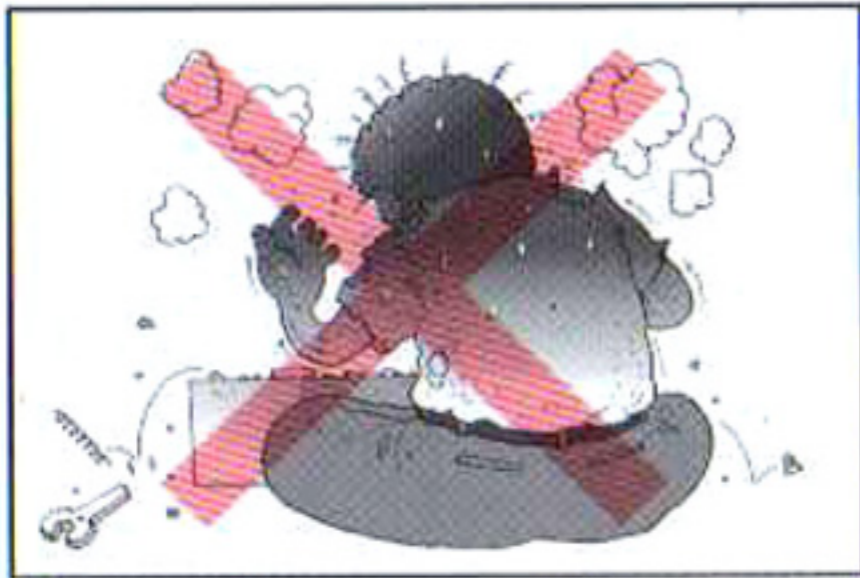

UNAUTHORIZED RECONSTRUCTION OF AIR SOFT GUN TO STRENGTHEN FIRING FUNCTION IS STRICTLY PROHIBITED.



DO NOT LOAD ANYTHING BUT BB BULLETS.

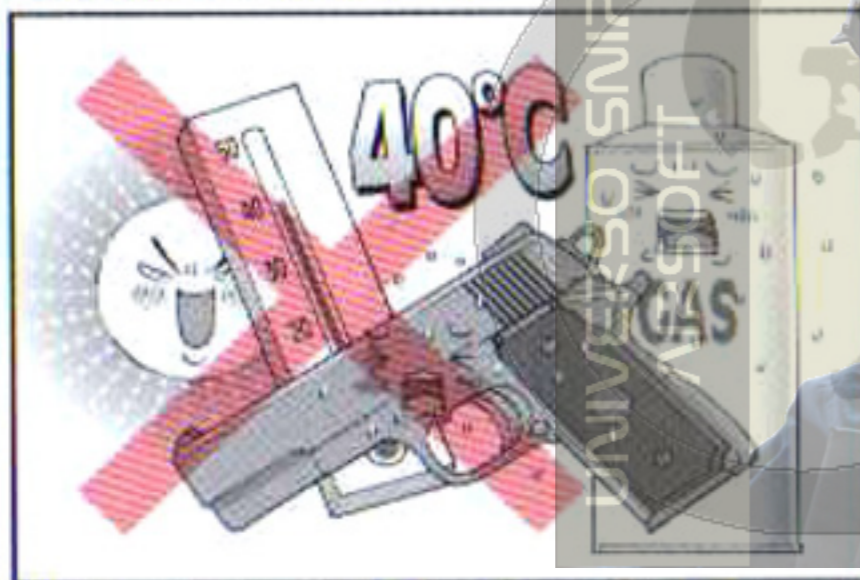

GUN AND GAS MUST BE PLACED IN AREA WHERE TEMPERATURE IS OVER 40 °C



PLEASE SHOOT IN SAFE PLACE

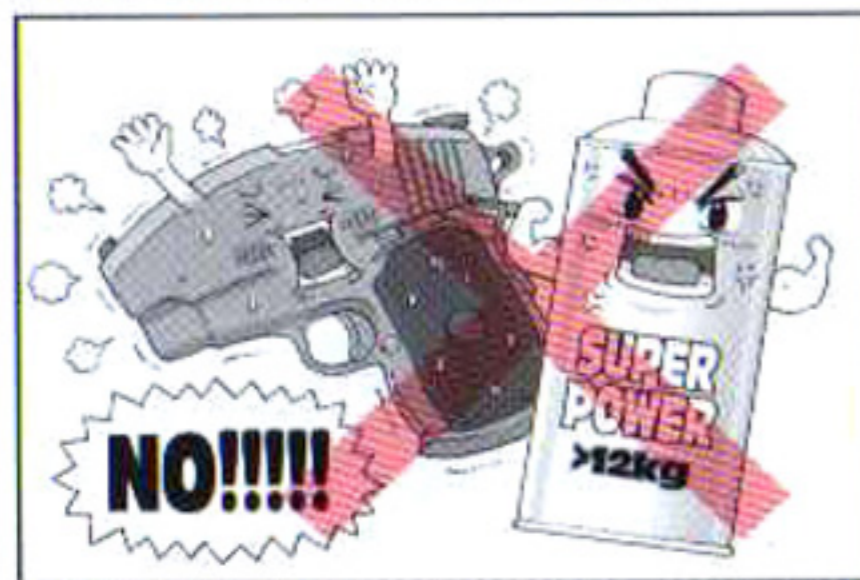

DO NOT USE GAS WHICH PRESSURE OVER 12 Kgs/cm²



EYE PROTECTION DEVICE MUST BE EQUIPPED

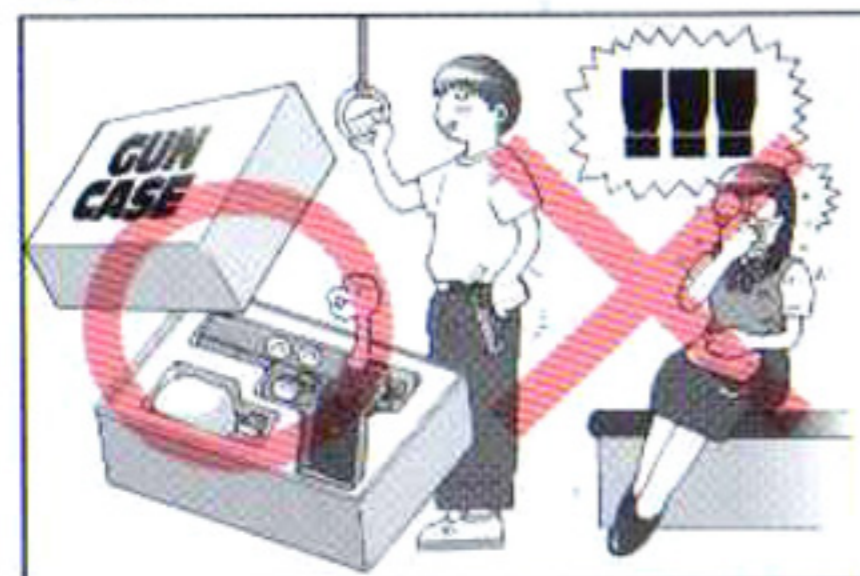

PLACE IN GUN CASE WHEN NOT IN USING OR TRANSPORTING



DO NOT LOOK THROUGH THE BARREL

OPERATING

1. RAISE THE BOLT HANDLE AND PULL IT ALL THE WAY BACK.



2. PRESS MAGAZINE CATCH AND PULL THE MAGAZINE OUT.

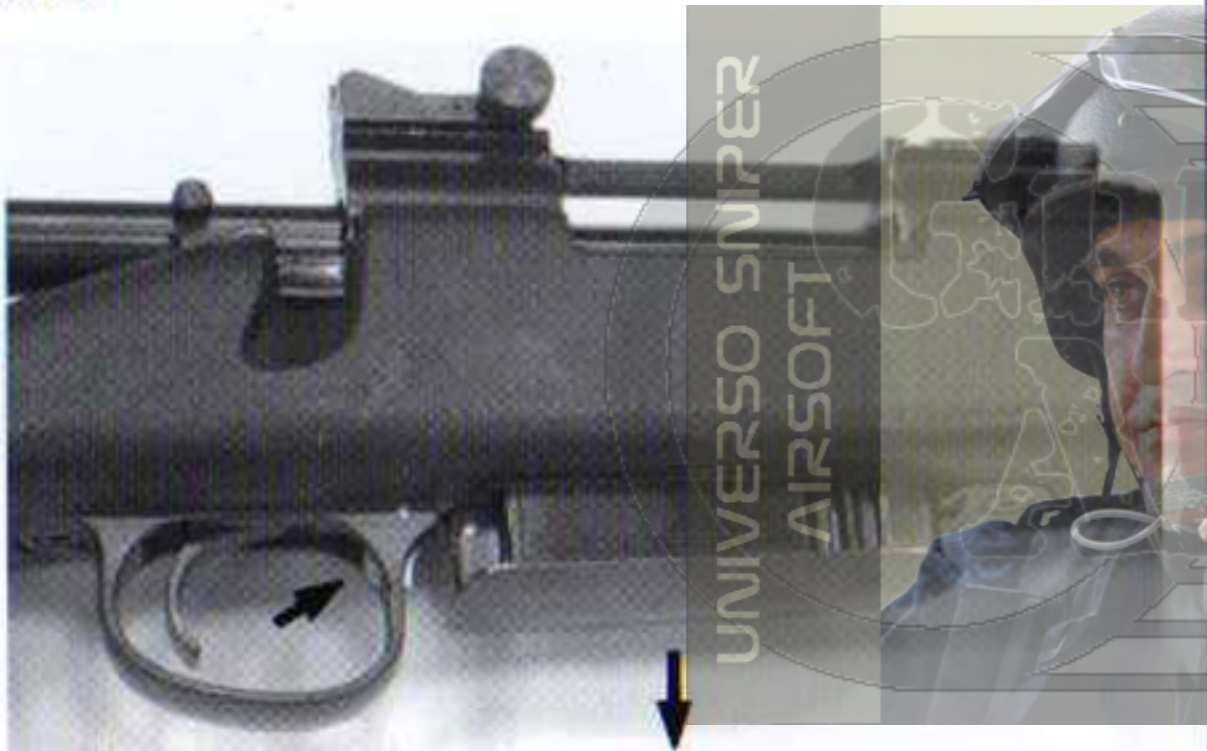

3. FILLING GAS.



4. LOAD THE BB BULLET AND INSERT THE MAGAZINE.

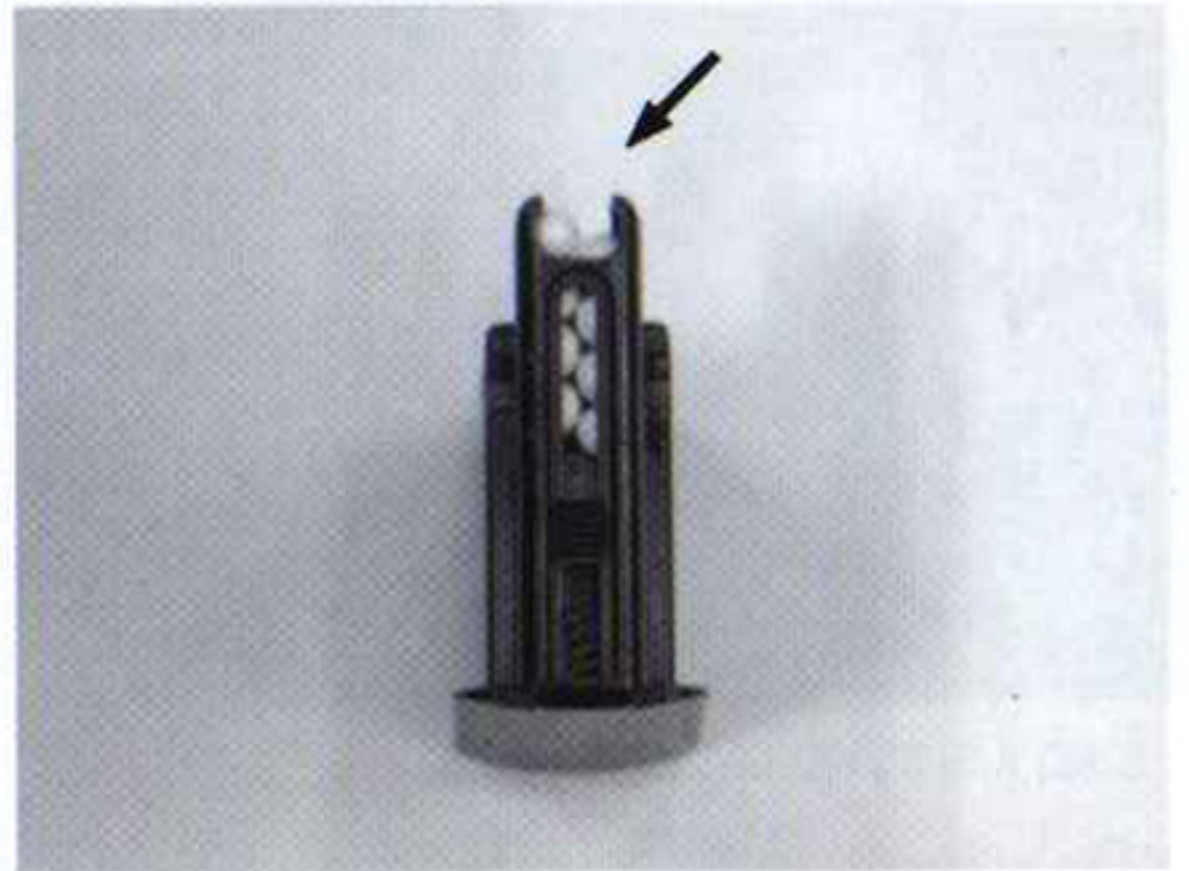

5. SLOWLY SLIDE THE BOLT FORWARD AND PUSH THE BOLT HANDLE DOWN.



6. SAFETY



TO ENGAGE THE SAFETY, PULL THE SAFETY FULLY TO THE REAR. WHEN YOU ARE READY TO FIRE, PUSH THE SAFETY FORWARD.

7.FIRE



8.ADJUST THE REAR SIGHT

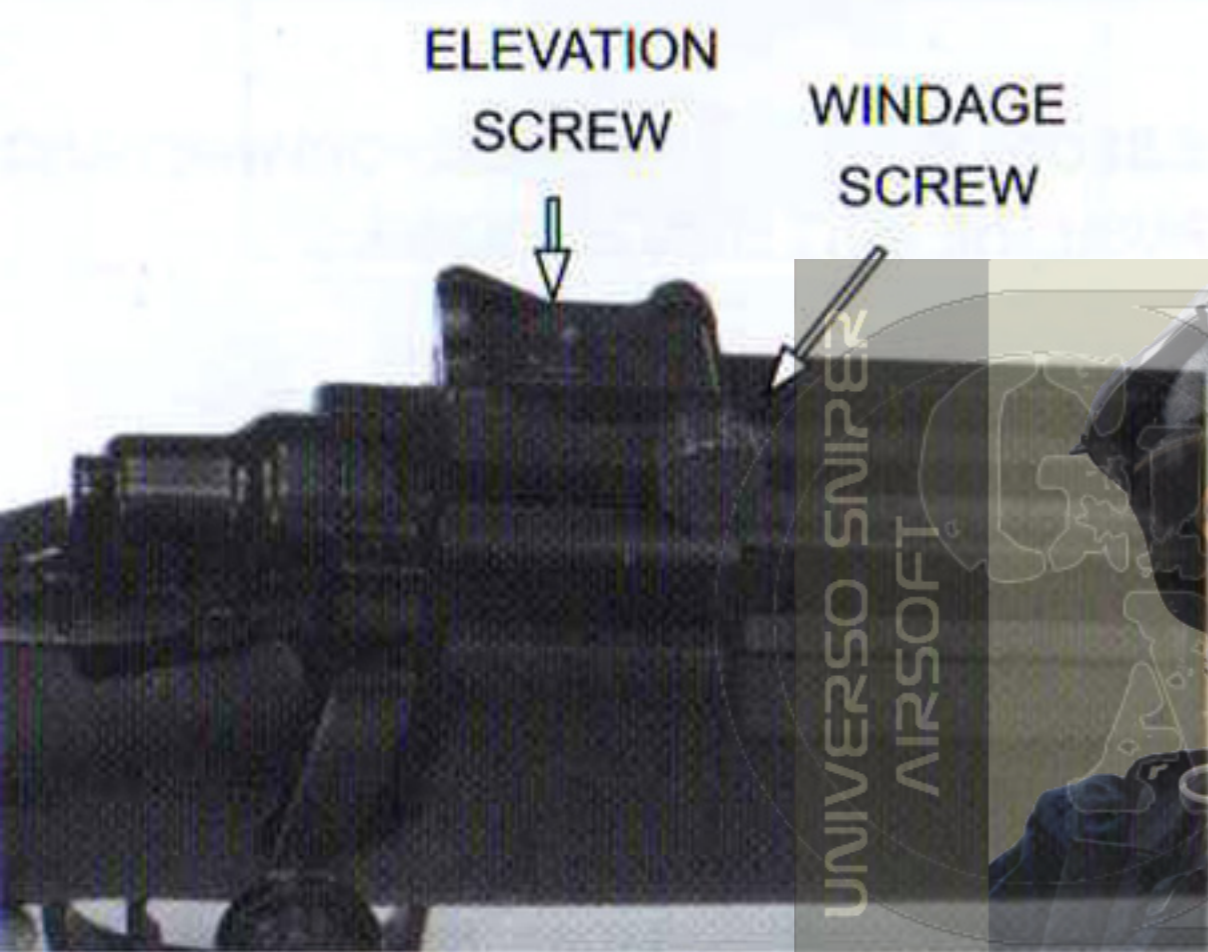

9.ADJUST THE TRAJECTORY.



TURN THE ADJUST KNOB TO ADJUST THE TRAJECTORY. IF THE BULLET FLIES TOO LOW, TURN THE KNOB CLOCKWISE. IF BULLET FLIES TOO HIGH, TURN THE KNOB ANTICLOCKWISE. UNTIL BULLET CAN REACH LONGEST DISTANCE.

10.ADJUST TRIGGER

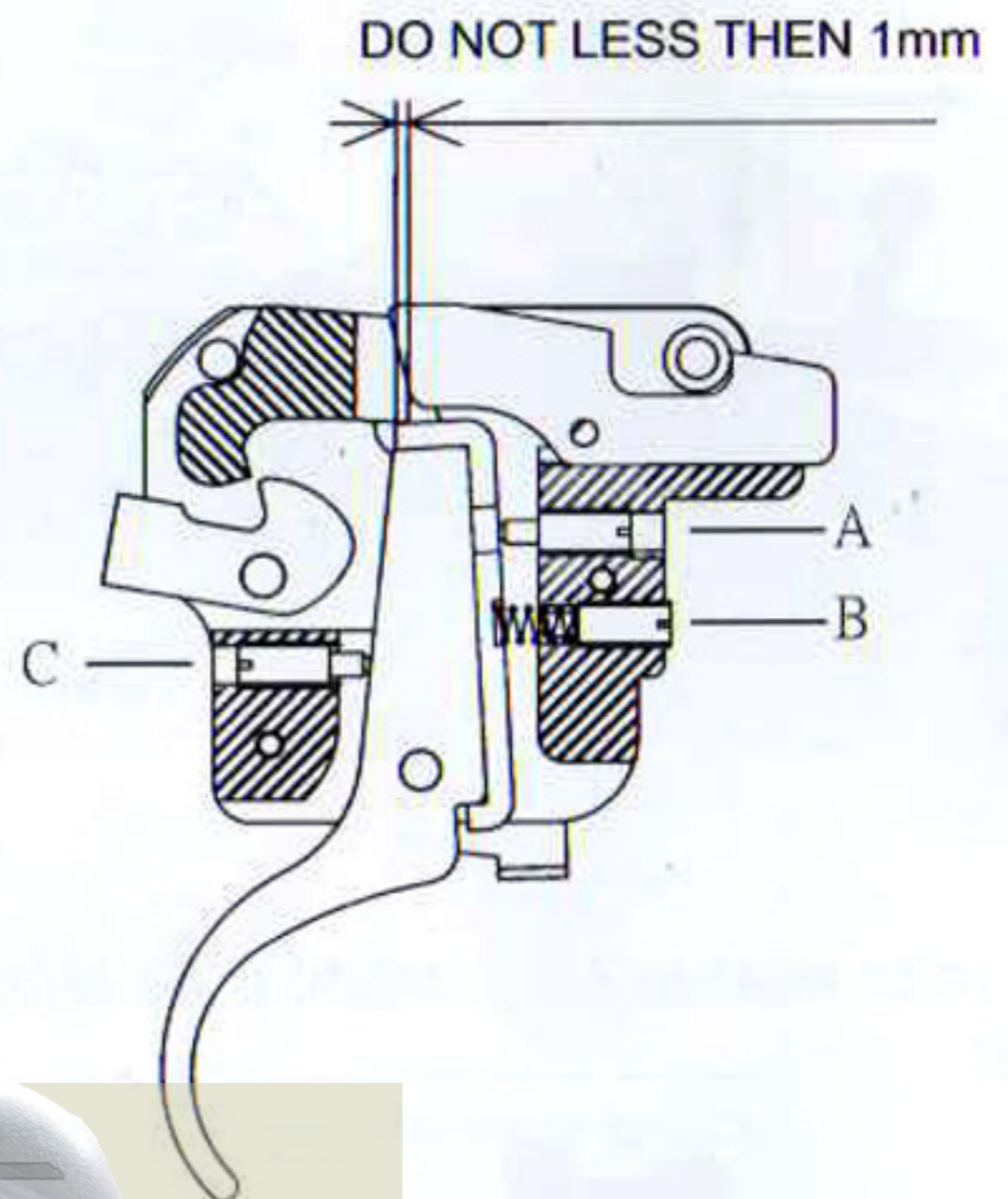

A.OVER TRAVEL SCREW

ADJUST THE SCREW TO EXTEND (ANTICLOCKWISE) OR SHORTEN (CLOCKWISE) TRIGGER OVER TRAVEL.

B.TRIGGER PULL SCREW

ADJUST THE SCREW TO INCREASE (CLOCKWISE) OR DECREASE (ANTICLOCKWISE) TRIGGER PRESSURE.

C.SEAR ENGAGEMENT SCREW

ADJUST THE SCREW TO SHORTEN (CLOCKWISE) OR EXTEND (ANTICLOCKWISE) SEAR ENGAGEMENT.

WARNING:SEAR ENGAGEMENT MUST NOT LESS THAN 1mm.

7.FIRE



8.ADJUST THE REAR SIGHT

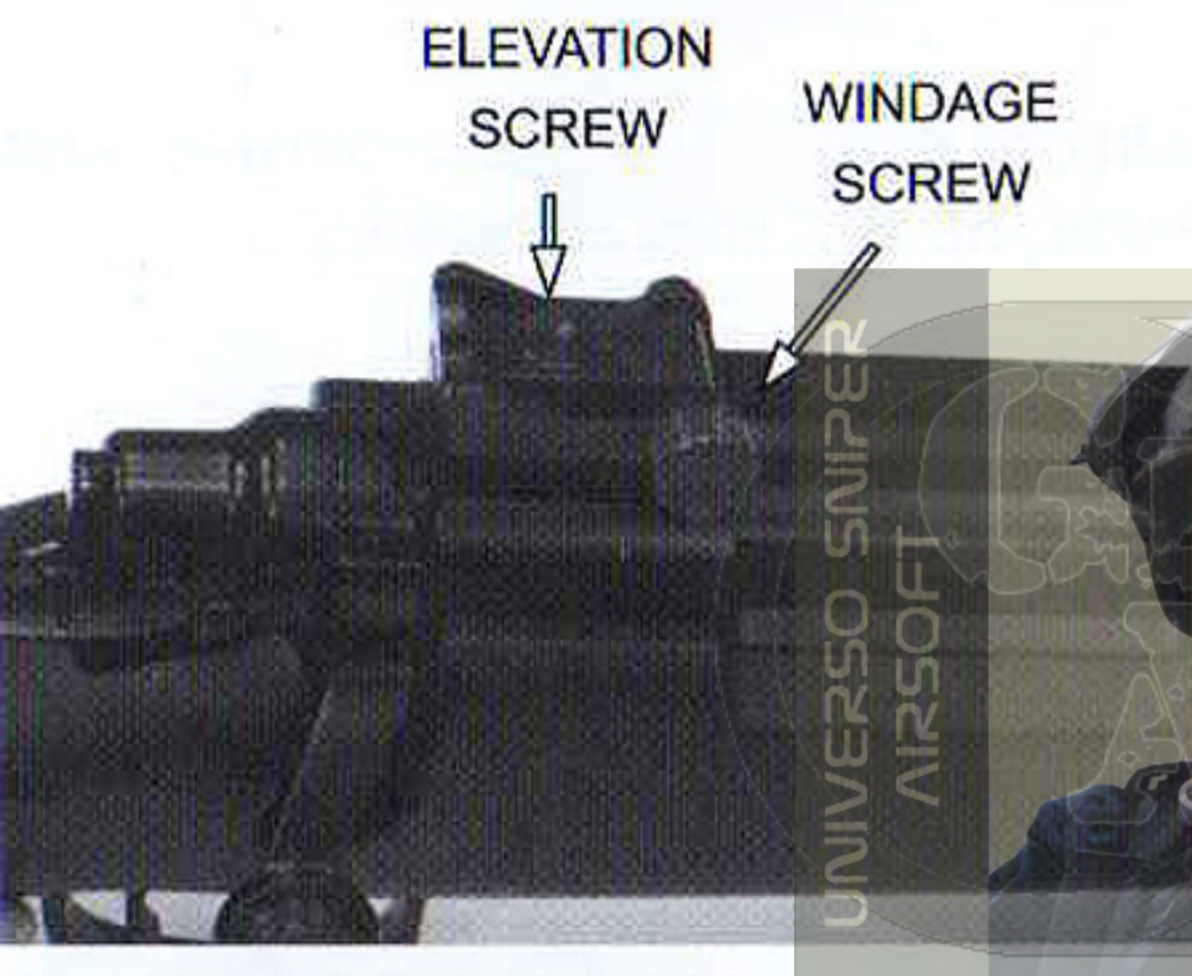

9.ADJUST THE TRAJECTORY.



TURN THE ADJUST KNOB TO ADJUST THE TRAJECTORY. IF THE BULLET FLIES TOO LOW, TURN THE KNOB CLOCKWISE. IF BULLET FLIES TOO HIGH, TURN THE KNOB ANTICLOCKWISE. UNTIL BULLET CAN REACH LONGEST DISTANCE.

10.ADJUST TRIGGER

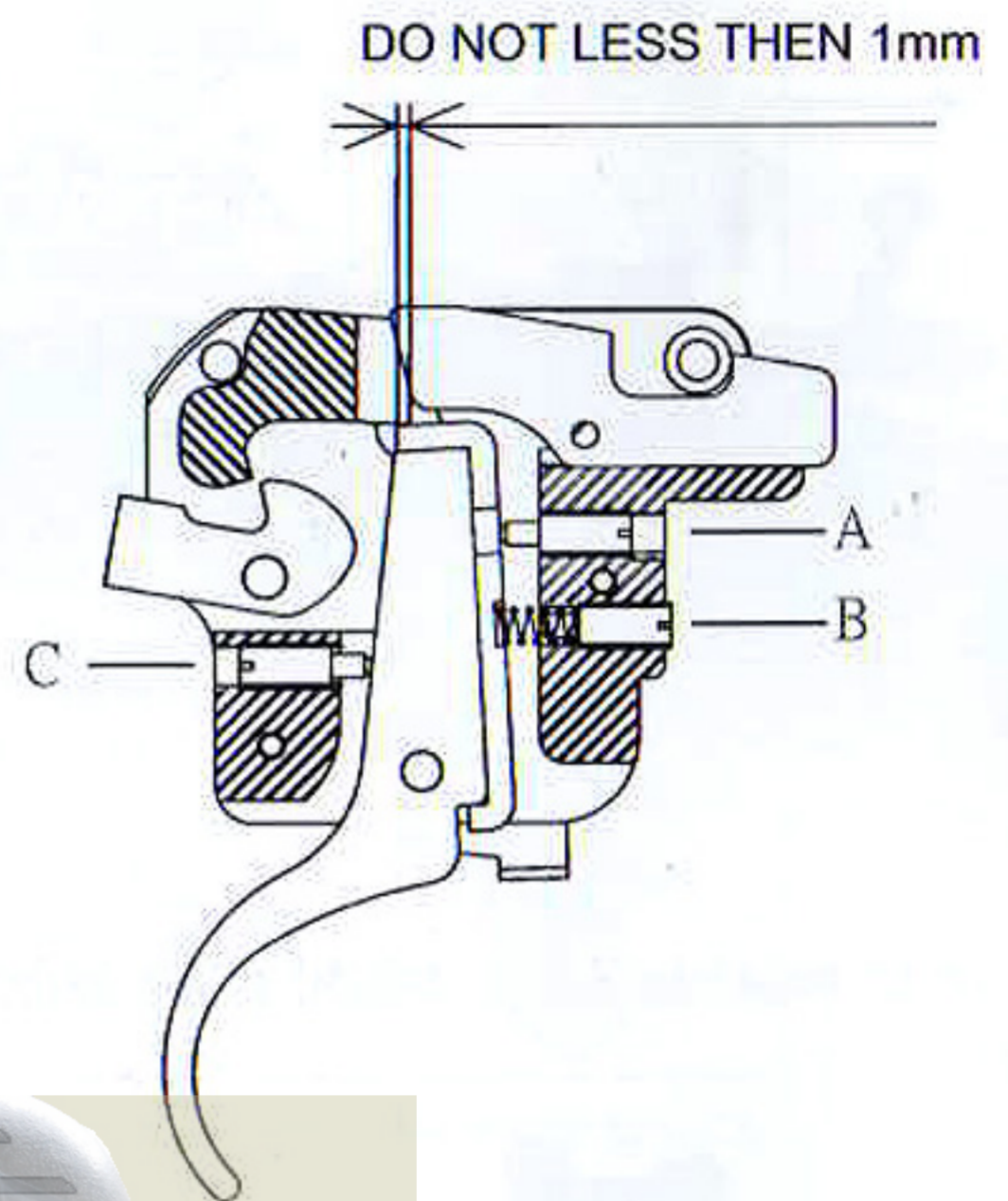

A.OVER TRAVEL SCREW

ADJUST THE SCREW TO EXTEND (ANTICLOCKWISE) OR SHORTEN (CLOCKWISE) TRIGGER OVER TRAVEL.

B.TRIGGER PULL SCREW

ADJUST THE SCREW TO INCREASE (CLOCKWISE) OR DECREASE (ANTICLOCKWISE) TRIGGER PRESSURE.

C.SEAR ENGAGEMENT SCREW

ADJUST THE SCREW TO SHORTEN (CLOCKWISE) OR EXTEND (ANTICLOCKWISE) SEAR ENGAGEMENT.

WARNING:SEAR ENGAGEMENT MUST NOT LESS THAN 1mm.

EXPLODED DRAWING

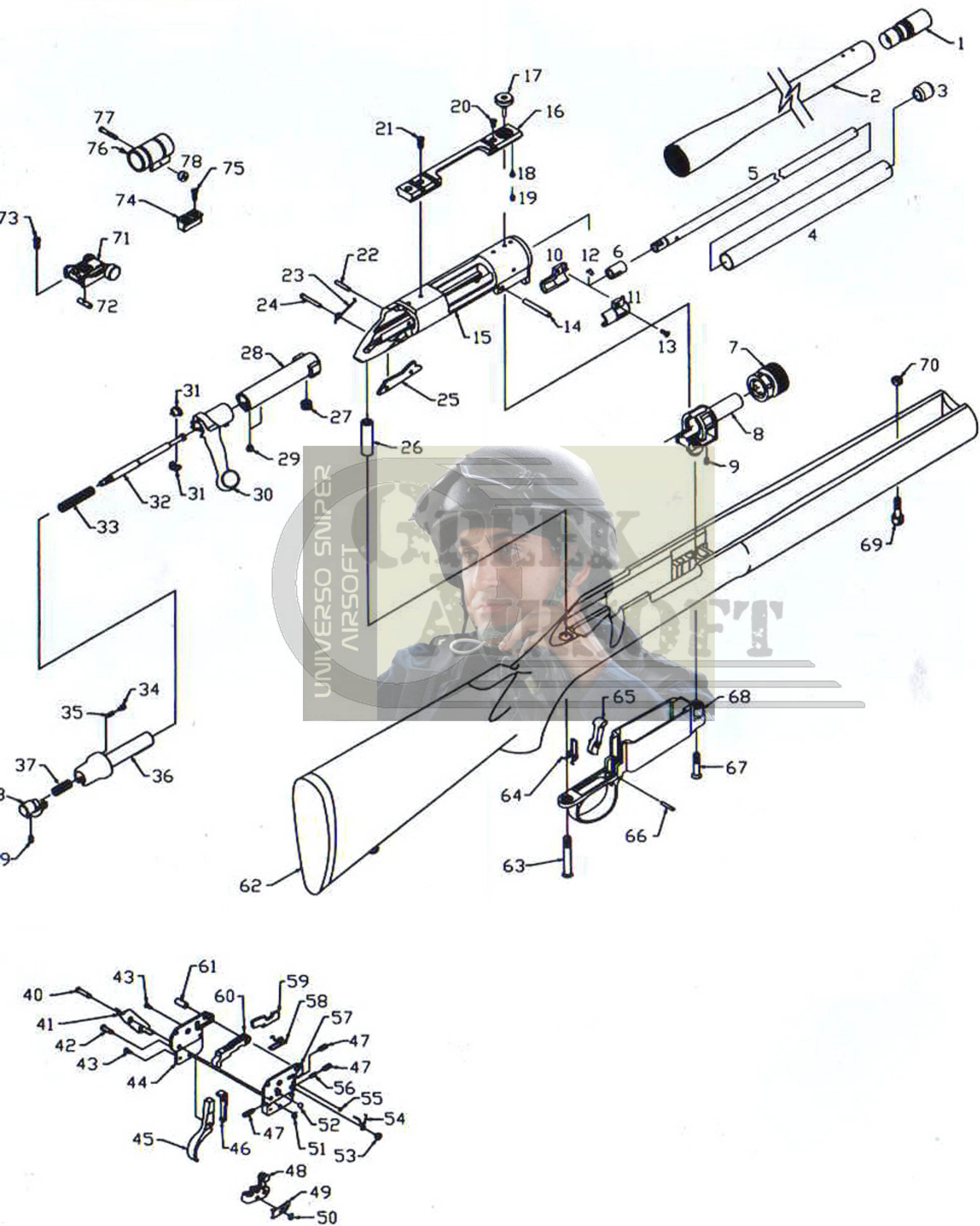

NO.	NAME	PRICE	NO.	NAME	PRICE
1	MUZZLE	200	40	SAFETY PIN	30
2	OUTTER BARREL	960	41	BOLT STOP RELEASE	80
3	INNER BARREL GUARD	40	42	TRIGGER PIN	50
4	INNER BARREL SLEEVE	150	43	TRIGGER HOUSING SCREW	20
5	INNER BARREL	800	44	TRIGGER HOUSING COVER	120
6	RUBBER CHAMBER	80	45	TRIGGER	120
7	BARREL LOCK SCREW	400	46	TRIGGER CONNECTOR	60
8	BARREL HOUSING	250	47	TRIGGER ADJUST SCREW	40
9	CHAMBER STOP SCREW	20	48	SAFETY	100
10	CHAMBER (LEFT)	120	49	SAFETY SPRING	80
11	CHAMBER (RIGHT)	120	50	SAFETY STOP	20
12	ADJUST PIECE	20	51	TRIGGER PIN STOP	20
13	CHAMBER SCREW	20	52	SAFETY DETENT BALL	20
14	BARREL HOUSING PIN	30	53	KNOCKER SPRING SCREW	30
15	RECEIVER	800	54	KNOCKER SPRING	50
16	RAIL MOUNT	300	55	TRIGGER ADJUSTMENT STOP	20
17	ADJUST KNOB	200	56	TRIGGER SPRING	20
18	ADJUST KNOB DETENT	30	57	TRIGGER HOUSING	220
19	ADJUST KNOB DETENT SPRING	20	58	SEAR SPRING	70
20	FRONT MOUNT SCREW	30	59	KNOCKER	80
21	REAR MOUNT SCREW	30	60	SEAR	100
22	SEAR PIN	20	61	SEAR PIN SLEEVE	40
23	BOLT STOP SPRING	50	62	STOCK	2800
24	BOLT STOP PIN	30	63	REAR GUARD SCREW	100
25	BOLT STOP	60	64	MAGAZINE CATCH SPRING	60
26	REAR GUARD SCREW BUSH	30	65	MAGAZINE CATCH	70
27	RUBBER CHAMBER	80	66	MAGAZINE CATCH PIN	20
28	BOLT	500	67	FRONT GUARD SCREW	80
29	BOLT SCREW	30	68	TRIGGER GUARD	700
30	BOLT HANDEL	300	69	FRONT SWIVEL SCREW	100
31	SPRING CAP	20	70	FRONT SWIVEL SCREW NUT	20
32	STRIKER	200	71	REAR SIGHT	480
33	STRIKER SPRING	100	72	ELEVATION SCREW NUT	50
34	BOLT DETENT	40	73	REAR SIGHT SCREW	30
35	BOLT DETENT SPRING	20	74	FRONT SIGHT BASE	120
36	BOLT SLEEVE	250	75	FRONT SIGHT BASE SCREW	20
37	REBOUND SPRING	40	76	FRONT SIGHT	240
38	COCKING PIECE	150	77	FRONT SIGHT SCREW	50
39	STRIKER STOP SCREW	20	78	FRONT SIGHT SCREW NUT	50

EXPLODED DRAWING

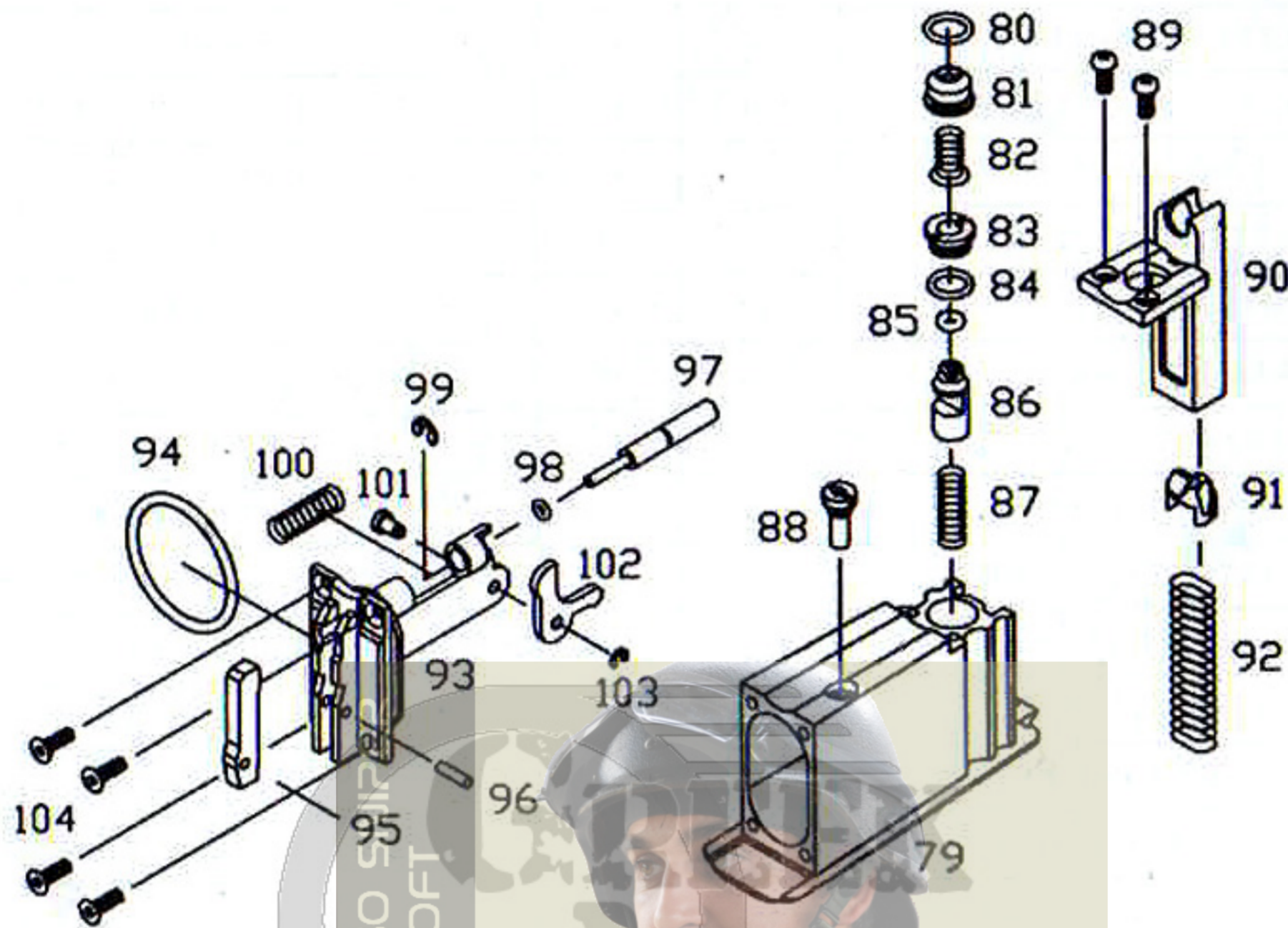

NO.	NAME	PRICE	NO.	NAME	PRICE
79	MAGAZINE CASE	500	92	FOLLOWER SPRING	70
80	COUPLER O-RING	20	93	MAGAZINE CAP	240
81	COUPLER	100	94	MAGAZINE CAP O-RING	40
82	COUPLER SPRING	50	95	KNOCKER CATCH	80
83	VALVE SCREW NUT	120	96	KNOCKER CATCH PIN	20
84	VALVE SCREW NUT O-RING	20	97	ARM PLUNGER	120
85	MAGAZINE SCREW NUT O-RING	20	98	ARM PLUNGER O-RING	20
86	MAGAZINE VALVE	120	99	ARM PLUNGER E-RING	20
87	MAGAZINE VALVE SPRING	50	100	ARM PLUNGER SPRING	50
88	FILLING VALVE	50	101	KNOCKER ARM PIN	40
89	MAGAZINE HOUSING SCREW	20	102	KNOCKER ARM	60
90	MAGAZINE HOUSING	200	103	KNOCKER E-RING	20
91	FOLLOWER	80	104	MAGAZINE CAP SCREW	20