



KRYTAC®

WINDUP SIMPLEX
AIRsoft



WINDUP
SIMPLEX

OWNER'S MANUAL

WAR SPORT

LVOA®-C

LVOA®-S

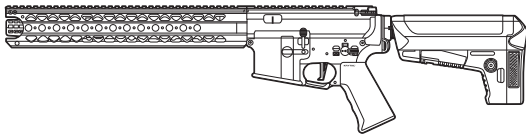
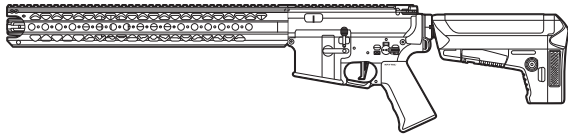

Officially licensed through War Sport Industries, LLC.

TABLE OF CONTENTS

Firearm Safety Rules	2
Specifications	4
Meter Per Second (MPS) diagram	6
Package Contents	6
Loading the Magazine	7
Fire Selector Switch.....	8
Battery Installation.....	9
Hop-Up System	10
Clearing Jammed BBs.....	11
Disassembly	12
Assembly.....	13
Main Spring Access.....	14
Cleaning and Maintenance.....	17
Operating Under Harsh Conditions	19
Hearing Protection Requirement.....	19
Contact Information.....	19
Trouble Shooting Guide.....	20
Component Diagrams and Lists.....	21

THIS PRODUCT IS NOT INTENDED FOR USE BY UNTRAINED PERSONS (INCLUDING CHILDREN) WITH OR WITHOUT PHYSICAL OR MENTAL HANDICAPS. THESE HANDICAPS INCLUDE REDUCED PHYSICAL, SENSORY OR MENTAL CAPABILITIES, OR LACK OF EXPERIENCE AND KNOWLEDGE OF THE PRODUCT AND SAFETY GUIDELINES. ALL USERS SHOULD HAVE TRAINED SUPERVISION OR INSTRUCTIONS CONCERNING THE USE OF THE APPLIANCE BY A PERSON RESPONSIBLE FOR HIS OR HER SAFETY.



WARNING

SAFETY RULES

Please read the entire KRYTAC manual before operating the airsoft gun. This manual covers important safety, operational, and maintenance topics. It is important that the user reads and understands the manual in order to safely handle and operate the airsoft gun. Failure to follow the safety guidelines and/or operational instructions in this manual may result in serious personal injury or damage to the airsoft gun.

Safety Guidelines

EYE PROTECTION

Always wear eye protection while shooting, operating, and maintaining your airsoft guns.

EAR PROTECTION

With noise levels exceeding 85dB(A), appropriate ear protection must be used to prevent any damages due to sound emissions.

FIREARM SAFETY RULES

Always assume that the airsoft gun is loaded. Never assume the chamber is empty based on memory or from someone else's word. An airsoft gun can still fire with the magazine removed.

KEEP YOUR FINGER OFF THE TRIGGER

Remove your finger from the inside of the trigger guard until your sights are aligned on target and you are ready to fire.

MUZZLE CONTROL

Always keep the muzzle of the airsoft gun pointed in a safe direction. Never point the airsoft gun towards anything you do not intend to shoot.

KNOW YOUR TARGET AND ITS SURROUNDINGS (SAFETY DISTANCE)

Take note of objects in front of and beyond your target. Airsoft guns can shoot up to and beyond 150 feet/45.5 meters and may travel further than intended without an adequate backstop. Never shoot an airsoft gun directly at targets such as rocks, glass, water, or other hard surfaces that may ricochet BBs in unpredictable directions.



WARNING

SAFETY IS YOUR RESPONSIBILITY

The KRYTAC airsoft gun is designed and manufactured to KRYTAC's high standards. It was carefully inspected before it was packaged and shipped from our factory. It is the sole responsibility of the user for its safe use and handling. This airsoft gun is safe unless handled irresponsibly or misused.

BEWARE OF BARREL OBSTRUCTIONS

Ensure that the barrel of your airsoft gun is free and clear of any obstructions prior to firing the airsoft gun. Failure to do so may cause a malfunction, and in some cases damage the airsoft gun.

KEEP THE SAFETY ON

Keep the fire selector set to safe until your sights are aligned on target and you are ready to fire.

SAFETY RULES

FAILURE TO FIRE

If the airsoft gun fails to fire, misfires, or malfunctions, do not look into/down the barrel of the airsoft gun. BBs can jam in the chamber and can launch suddenly while under pressure causing serious injury.

FUSE

DO NOT REMOVE OR BYPASS THE FUSE. It is an integral part of the system, alterations to the fuse will void warranty and may result in operational failure and critical damage to internal components.

MAINTAIN YOUR AIRSOFT GUN PROPERLY

Maintaining your airsoft gun as outlined in the manual ensures that your airsoft gun will be safe to shoot and perform to its designed specifications. Alterations, modifications, or adjustments may damage your airsoft gun, making it unsafe to shoot and/or voiding all warranty claims.

STORAGE AND TRANSPORT

Keep the fire selector on the airsoft gun set to safe, with the magazine and battery removed when storing your airsoft gun. Always store your airsoft gun in a safe place and out of the reach of children. When transporting your airsoft gun make sure that it is in a designated airsoft gun case. Never brandish your airsoft gun in public.



WARNING

IT IS YOUR RESPONSIBILITY TO SAFELY STORE AND TRANSPORT YOUR AIRSOFT GUN.

ORANGE TIP

Any alteration of the coloration or markings required by state and/or federal law may be deemed illegal in a court of law. All risks and responsibility of any alteration to the product will be assumed by the operators, owners and/or user of the product.



WARNING

THE ORANGE TIP DOES NOT DISTINGUISH YOUR AIRSOFT GUN AS A TOY, ALWAYS TREAT YOUR AIRSOFT GUN AS IF IT IS A REAL FIREARM.

HAZARDS OF BEING MISTAKEN FOR A REAL FIREARM

Due to the nature and design of some airsoft guns, they may be mistaken as a real firearm. It is strongly advised to operate an airsoft gun in the safety and privacy of your own home, or at a legally sanctioned location or game field. Police, Peace Officers, and Law Enforcement Officers are trained to treat objects that resemble a firearm as one. In the event that you are approached by a Law Enforcement Official, completely comply with their instructions. Never point an airsoft gun at a Law Enforcement Official. Confrontation with a Law Enforcement Official may result in serious injury or death.

ALCOHOL, MEDICATIONS AND DRUGS

Do not handle or operate your airsoft gun while under the influence of alcohol, medication, or drugs that may impair judgment.

SPECIFICATIONS

WAR SPORT LVOA®-C



Overall Length	830 mm (32.68") - 910 mm (35.83")
Overall Height	185 mm (7.28")
Weight	2.8kg (6.17 lbs)
Outer Barrel Length	14.5"
Inner Barrel Length	395 mm
Inner Barrel Diameter	6.05 mm



CALIBER
6 MM

MECHBOX

Krytac Trident Mechbox
with 8 mm Bearing

RATE OF FIRE
20+ RPS

PERFORMANCE DETAILS ARE BASED ON U.S. SPECIFICATIONS AND CAN BE MODIFIED TO MEET THE LAWS AND REGULATIONS OF YOUR LOCAL REGION.

PRODUCT FEATURES

Licensed War Sport LVOA® metal alloy receivers

Licensed War Sport LVOA®-C rail

Licensed War Sport top Hat flash hider

Licensed DEFIANCE® pistol grip

KRYTAC battery stock

MIL-STD 1913 Picatinny top rail

Ambidextrous fire selector

Modular hand guard rail section

Adjustable iron sights

Integrated FET system

Easy maintenance spring guide

Padded cylinder head

Relief-cut cylinder window

Anti-corrosion mechbox coating

Adjustable rotary Hop-Up

Temperature and wear resistant hop-up bucking

Spring relief mechanism

SPECIFICATIONS

WAR SPORT LVOA®-S



Overall Length	755 mm (29.72") - 840 mm (33")
Overall Height	185 mm (7.28")
Weight	2.77kg (6.10 lbs)
Outer Barrel Length	12.4"
Inner Barrel Length	310 mm
Inner Barrel Diameter	6.05 mm



CALIBER
6 MM

UNIVERSAL SLIP
AIR-CFT



MECHBOX
Krytac Trident Mechbox
with 8 mm Bearing

SYSTEM OF
TACTICAL

RATE OF FIRE
20+ RPS

PERFORMANCE DETAILS ARE BASED ON U.S. SPECIFICATIONS AND CAN BE MODIFIED TO MEET THE LAWS AND REGULATIONS OF YOUR LOCAL REGION.

PRODUCT FEATURES

Licensed War Sport LVOA® metal alloy receivers

Licensed War Sport LVOA®-S rail

Licensed War Sport top Hat flash hider

Licensed DEFIANCE® pistol grip

KRYTAC battery stock

MIL-STD 1913 Picatinny top rail

Ambidextrous fire selector

Modular hand guard rail section

Adjustable iron sights

Integrated FET system

Easy maintenance spring guide

Padded cylinder head

Relief-cut cylinder window

Anti-corrosion mechbox coating

Adjustable rotary Hop-Up

Temperature and wear resistant hop-up bucking

Spring relief mechanism

METER PER SECOND (MPS) DIAGRAM

Please check the chart below to see what the maximum velocity is for your region. If your region requires you to adjust your airsoft gun's velocity, please see Main Spring Access section for instruction.

Country	Max Velocity	Models
Japan, Italy	99 m/s	War Sport LVOA®-C LVOA®-S
UK	110 m/s	War Sport LVOA®-C LVOA®-S
Austria, Belgium, Bosnia and Herzegovina, Bulgaria, Croatia, Cyprus, Czech Republic, Denmark, Estonia, Finland, France, Germany, Hungary, Iceland, Latvia, Liechtenstein, Lithuania, Macedonia, Moldavia, Netherlands, Norway Poland, Portugal, Romania, Serbia, Slovakia, Slovenia, Spain, Sweden, Switzerland, Canada, U.S.A.	120 m/s	War Sport LVOA®-C LVOA®-S



PACKAGE CONTENTS

- [1] War Sport LVOA®-C / LVOA®-S airsoft gun
- [1] Magazine
- [1] Set of front and rear sights
- [1] User's manual
- [1] Cleaning rod

LOADING THE MAGAZINE

High-Cap

1. Place the hi-cap magazine with the trap door (A) facing upward. Open the trap door and dispense BBs into the BB well.
2. When full, close the trap door and turn the winding wheel (B) forward until the 'clicking' changes tone.

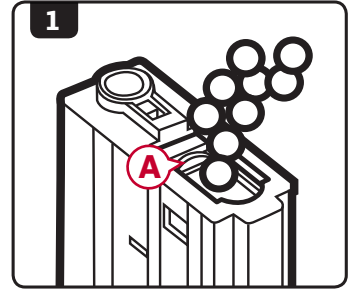

WARNING

DO NOT OVER LOAD THE MAGAZINE

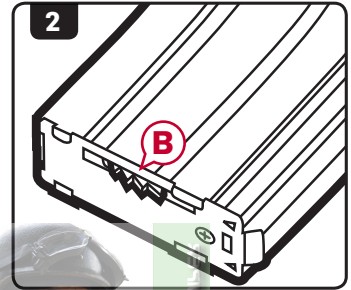

Mid-Cap

1. Using a speed loader or other magazine loader, insert the nozzle into the opening of the magazine.
2. Press down on the loader plunger to load BBs into the magazine.
3. Stop once the magazine is full, do not force more into the magazine.

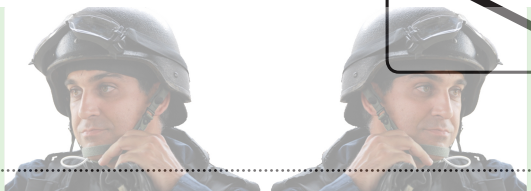

FIRE SELECTOR SWITCH

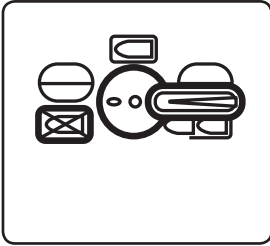

SAFE MODE

When in safe mode, the trigger will not engage and the airsoft gun will not fire.

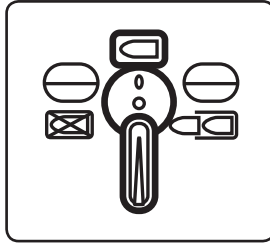

SEMI-AUTO MODE

While in semi-auto mode, the airsoft gun will only fire one shot for each time the trigger is engaged.

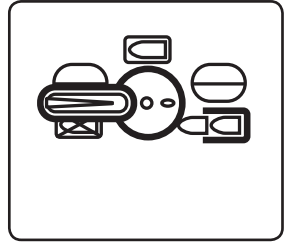

FULL-AUTO MODE

In full-auto mode, the gun will continuously fire as long as the trigger remains engaged.

SAFETY TIP

It is advised when you are not ready to fire, keep the fire selector switch on the airsoft gun in the safe position.



WARNING

DO NOT ENGAGE THE TRIGGER WHILE SWITCHING BETWEEN MODES ON THE FIRE SELECTOR.

BATTERY INSTALLATION



ENSURE THAT THE STOCK IS IN THE FULLY COLLAPSED POSITION BEFORE OPENING THE STOCK COVER. DO NOT REMOVE THE STOCK COMPLETELY FROM THE GUN.

1. Set the fire selector to safe mode and depress the stock cover release button **A** on both sides of the stock to lift and remove the cover.

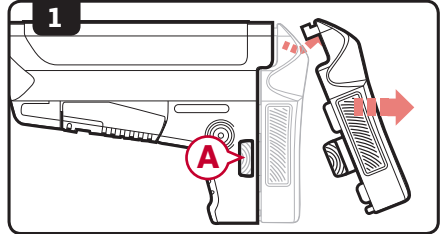

2. Connect either a nunchuck battery or small LiPo battery to the connector and place the battery into the stock. Push the connector plugs **B** together firmly until they lock into place.

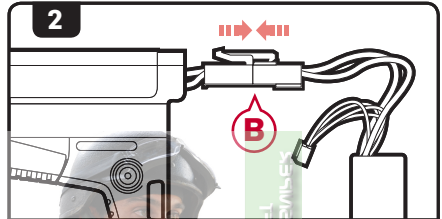

a. Place the small LiPo battery **C** so that it rests at the rear of the stock.

b. Place the nunchuck style batteries **D** down either side of the battery tubes found on the sides of the stock.

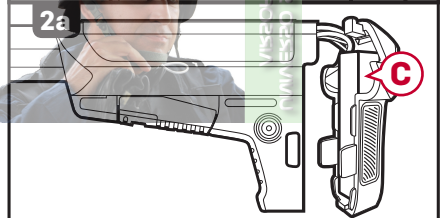

3. Replace the stock cover by first placing the tab **E** of the cover into the stock and then rocking the stock cover down into position. Ensure that the stock cover release buttons snap securely into place.

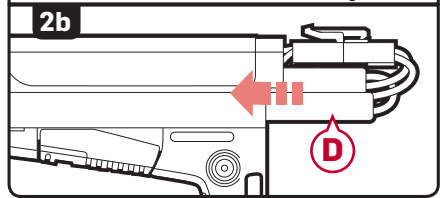

WARNING

EXCESSIVE PULLING OR TUGGING OF THE BATTERY WIRES WHEN INSERTING OR REMOVING THE BATTERY CAN CAUSE THE FUSE HOUSING TO COME LOOSE OR DAMAGE TO THE GUN.

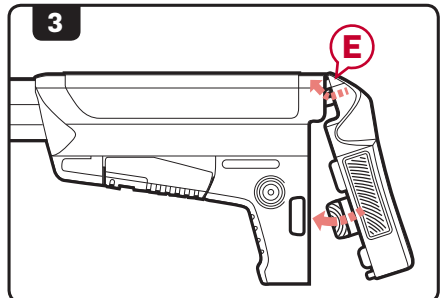

HOP-UP SYSTEM

The advanced KRYTAC rotary Hop-Up unit is a standard feature in KRYTAC AEGs. Proper adjustment of the Hop-Up will allow the AEGs to fire in a variety of shooting environments to obtain optimal BB trajectory.

Hop-Up Adjustment

1. Pull the charging handle (A) rearward locking the bolt plate (B). This will provide access to the Hop-Up adjustment dial (C).
2. Turn the dial up or down, an audible click will confirm each adjustment.
3. Increasing the number on the dial will increase the amount of Hop-Up on the BB. Decreasing the number will lower the amount of Hop-Up on the BB.
4. Once the Hop-Up has been set, depress the bolt catch release (D) to return the bolt plate back to its fully seated position.

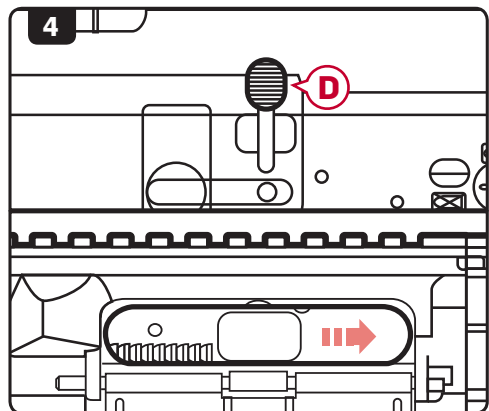
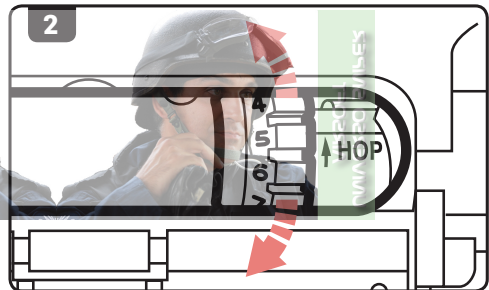
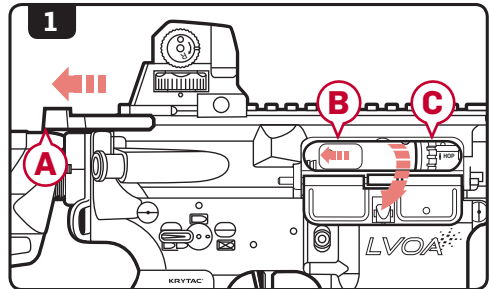

HOP-UP SYSTEM

Excessive Hop-Up

Airsoft BB travels in an extreme upward trajectory. Decrease the Hop-Up.

Ideal Hop-Up

Airsoft BB travels in a long, horizontal flight path.

Insufficient Hop-Up

Airsoft BB travels a short distance in a downward trajectory. Increase the Hop-Up.

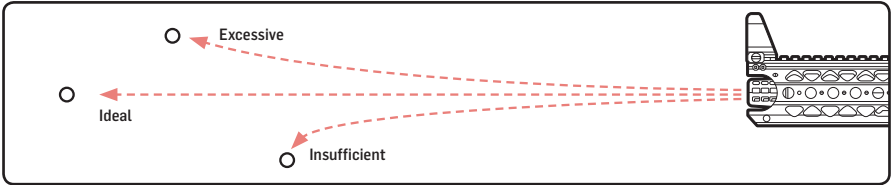

CLEARING JAMMED BBS

1. Disassemble the airsoft gun and remove the inner barrel assembly **(A)**. (see pg.12 for disassembly instruction).
2. Lift the Hop-up lever **(B)** from the inner barrel assembly (refer to step 3 of pg.17).
3. Take the cleaning rod **(C)** and insert the unjamming side from the front of the barrel through to the rear to clear out the jammed BB.
4. Look through the barrel to ensure that it is cleared.
5. Reassemble the airsoft gun. (see pg.13 for assembly instruction).

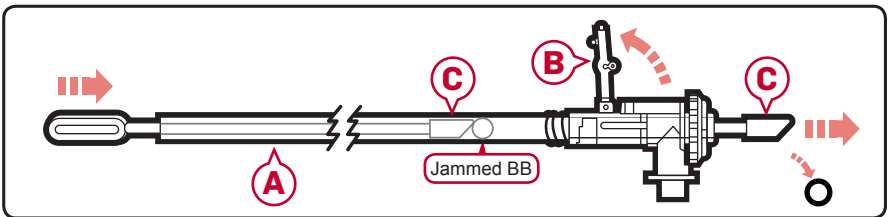

NOTE

Use only new, quality airsoft BBs. Never use recycled or low quality airsoft BBs, doing so may cause excessive jamming. In most cases, it can severely damage the internal gearbox and/or Hop-Up and inner barrel.

DISASSEMBLY

NOTE

Before opening up the receiver, remove the magazine and fire the airsoft gun in a safe direction to ensure that the Hop-Up chamber is clear of any BBs.

1. Set the AEG to safe mode.
2. Remove the stock cover and disconnect the battery.
3. Pull the charging handle rearward to lock the bolt plate back.
4. Remove **ONLY** the front pin **(A)** from the receiver.
5. Slide the upper receiver forward and away from the lower receiver.

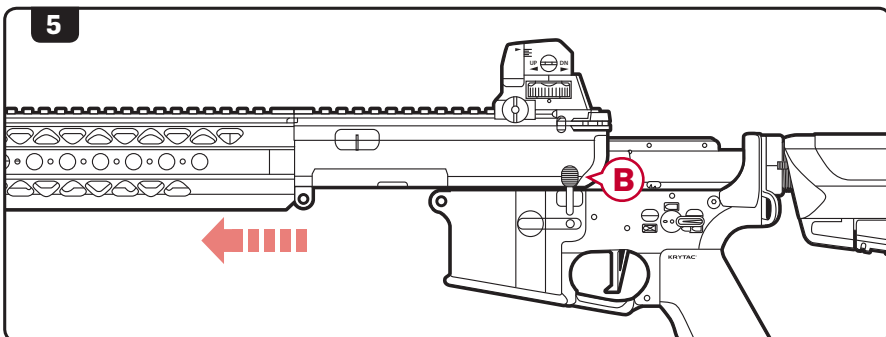
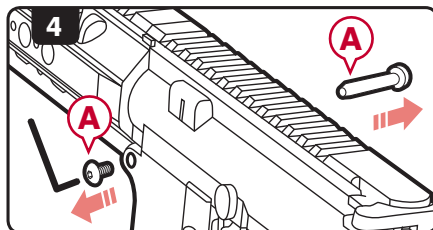
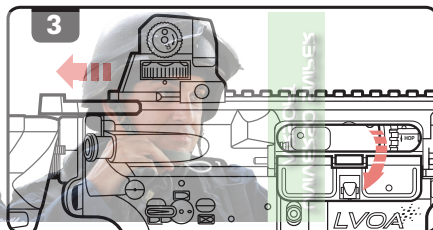
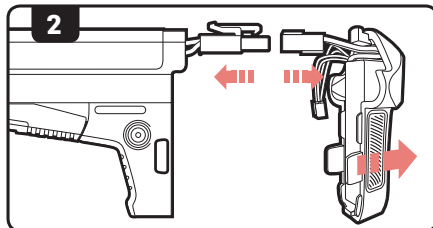
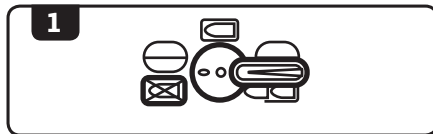

NOTE

The bolt catch lever **(B)** may fall off of the lower receiver when separating the receivers. Avoid turning or jostling the lower receiver to help prevent loss of the bolt catch lever.

DISASSEMBLY

- Slide the Hop-Up and inner barrel assembly **C** out of the upper receiver.

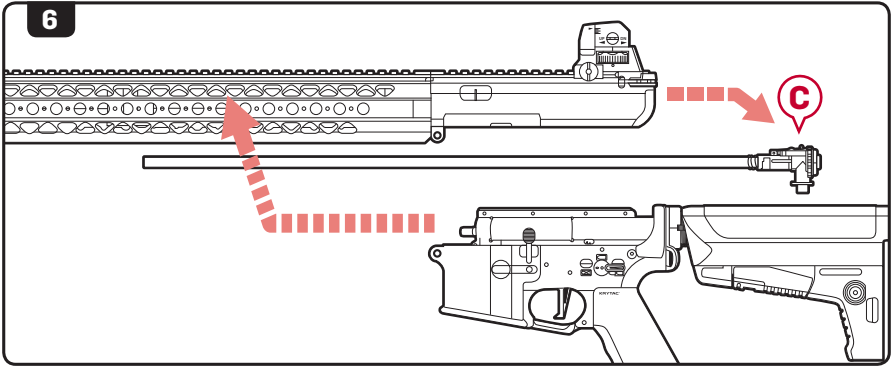

ASSEMBLY

- Insert the Hop-Up and inner barrel assembly into the upper receiver.
- Ensure that the bolt catch lever is in place, then slide the upper receiver back onto the lower receiver.
- Reinstall and secure the front body pin.

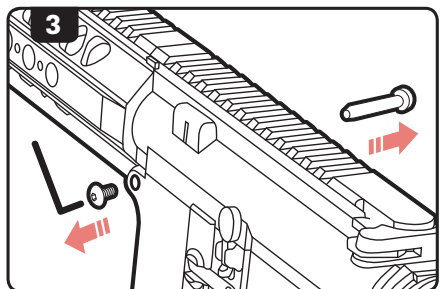
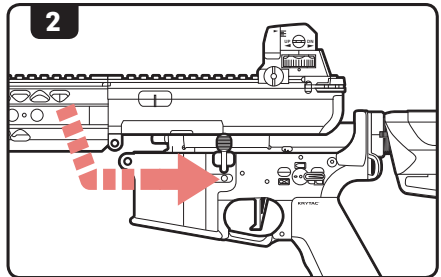
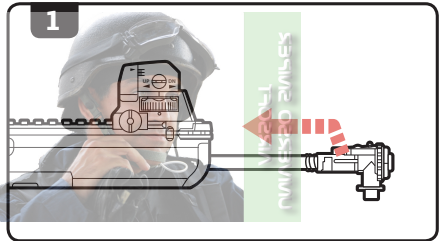

MAIN SPRING ACCESS



PLEASE REVIEW THE WARRANTY CARD INFORMATION BEFORE OPENING AND/OR MODIFYING THE KRYTAC AIRSOFT GUN.

1. Disassemble the airsoft gun. (see pg.12 for disassembly instruction).
2. Remove the bolt release button **(A)**.
3. Pull down on the tab of the stock adjustment lever **(B)**, slide the stock **(C)** rearward and off the buffer tube **(D)**.
4. Use a Phillips (P3) screw driver to remove screw **(E)** and washer **(F)** from inside the buffer tube **(D)**.
5. Remove the buffer tube **(D)**.
6. Remove the sling plate **(G)**.

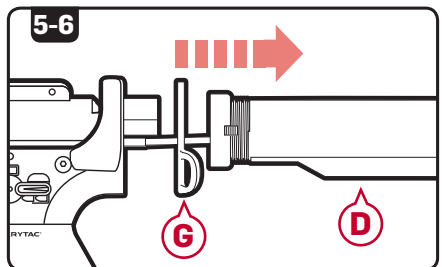
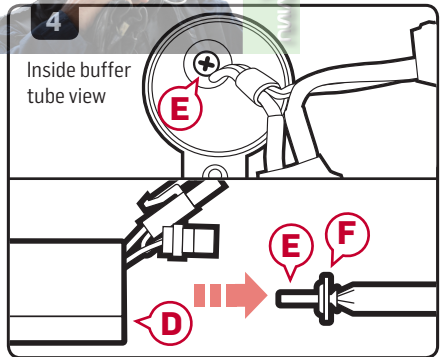
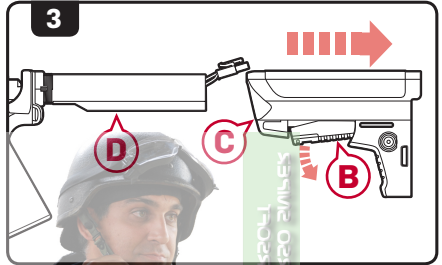
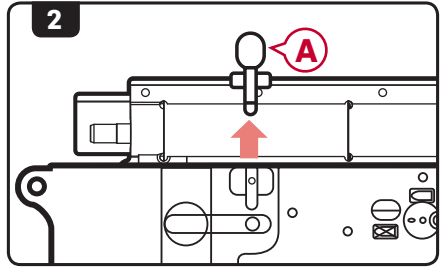

MAIN SPRING ACCESS

7. Remove the screw **(H)** from the magazine release button **(I)** using a Phillips screw driver, then remove the magazine release button **(I)**.
8. Use a Phillips P2 screw driver to remove 2 screws **(J)** on the bottom of the motor plate **(K)** then remove the motor plate.

NOTE

Take note of the wire and motor orientation before disconnecting.

9. Disconnect the motor wires **(L)** and remove the motor **(M)**.
10. Remove 2 Phillips P2 screws **(N)** at the top of the motor grip interior, then remove the motor grip **(O)**.
11. Remove the right side selector switch **(P)** using a 1.5 mm hex key.

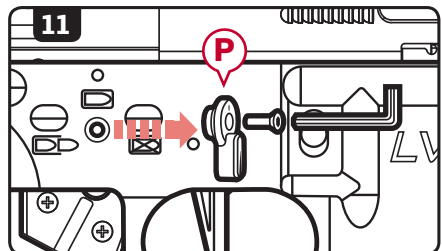
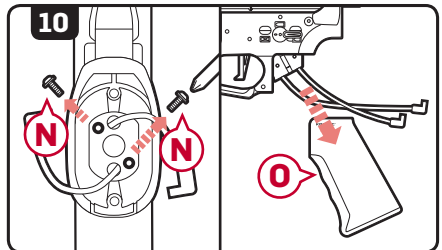
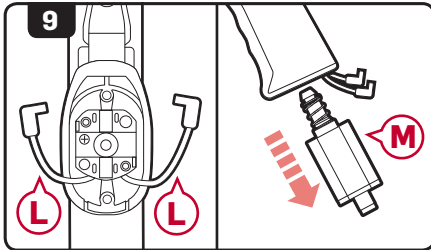
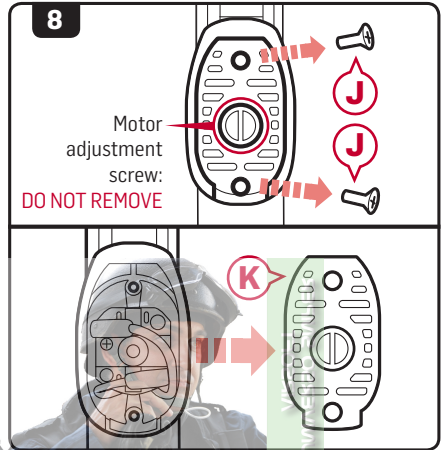
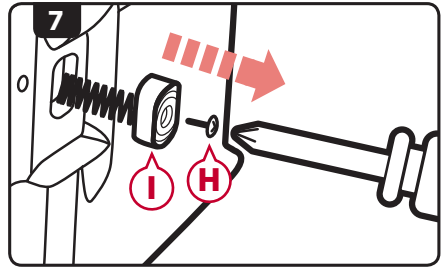

MAIN SPRING ACCESS

12. Use a 2.5 mm hex key to remove the rear receiver pin screw **Q** then press the rear receiver pin **R** in and remove it from the other side of the airsoft gun.

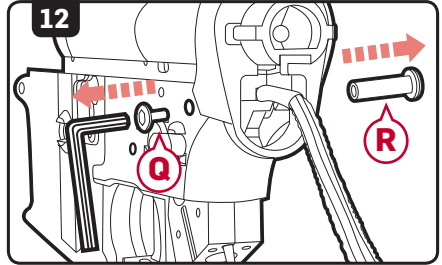

13. Use a 2.5 mm punch **S** and press the body pin **T** in and remove it from the other side of the airsoft gun.

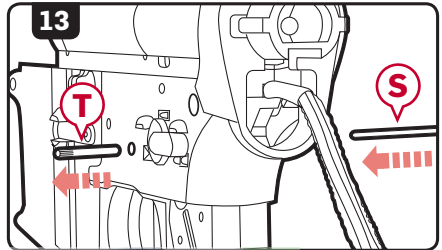

14. Move the selector switch **U** half way between safe mode and semi-automatic mode then slide the gearbox **V** out of the lower receiver.

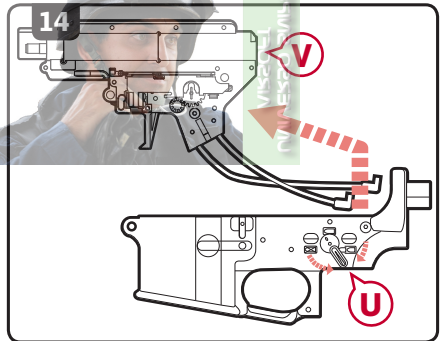

NOTE

Spring guide is under extreme pressure. Remove with caution.

15. Use a 8 mm hex key **W**, push the spring guide **X** into the gearbox, turn 90° counter clockwise then pull the spring guide and spring **Y** out.

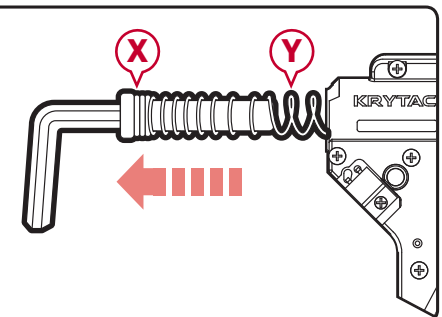
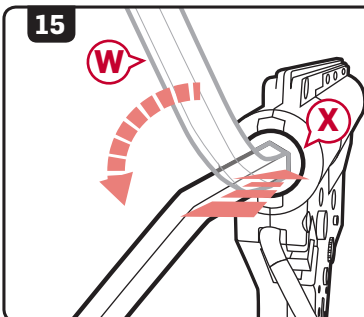

16. Re-insert spring guide with desired spring into gear box. Follow steps in reverse order to reassemble the airsoft gun.

CLEANING AND MAINTENANCE

NOTE

WHILE POINTING THE AIRSOFT GUN IN A SAFE DIRECTION, REMOVE THE MAGAZINE AND CYCLE THE GEARBOX UNTIL NO BBS EXIT THE INNER BARREL. PLACE THE AIRSOFT GUN IN SAFE MODE AND DISCONNECT THE BATTERY PRIOR TO ANY CLEANING PROCEDURES.

1. Wipe down the external parts of the gun and remove any dirt and debris.
2. Disassemble the airsoft gun as described in the Disassembly section and pull out the barrel and Hop-Up assembly (A).
3. Pull back on the Hop-Up adjustment wheel (B) and lift the Hop-Up adjustment lever (C) up.
4. Take a lint-free cleaning patch (D) and place it through the looped end of the cleaning rod (E).

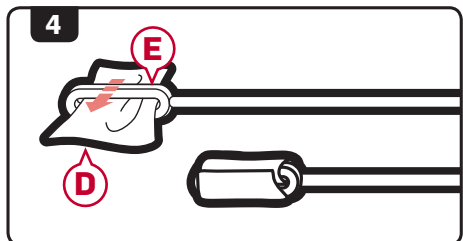
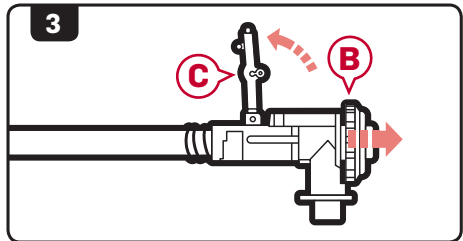
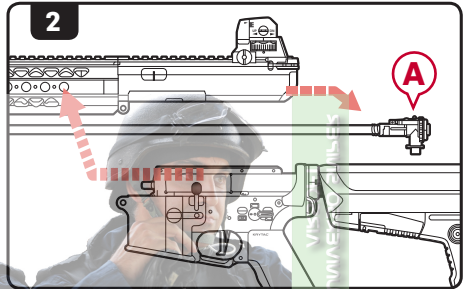
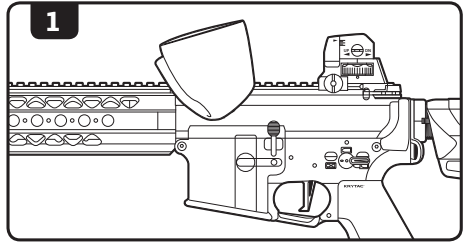

WARNING

DO NOT ADD OIL TO THE HOP-UP BUCKING. EXCESSIVE OIL ON THE HOP-UP BUCKING MAY NEGATE THE HOP-UP, DECREASING RANGE AND ACCURACY.

CLEANING AND MAINTENANCE

5. Run the cleaning rod through the barrel from back to front (in the same direction that BBs travel).

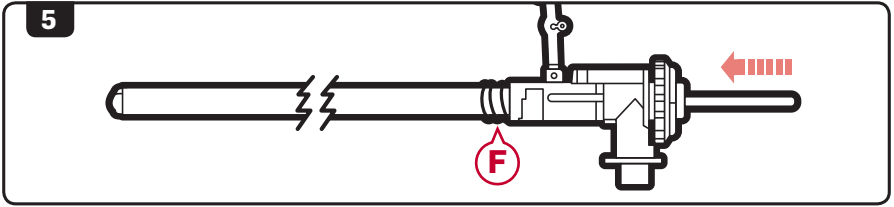

WARNING

KEEP TRACK OF THE BARREL SPRING (F), IT CAN SEPARATE FROM THE BARREL ASSEMBLY.

6. Pull back on the Hop-Up adjustment wheel and lower the Hop-Up adjustment lever back into position.

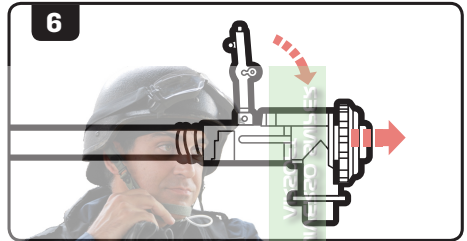

7. Reinsert the Hop-Up barrel assembly into the receiver and reassemble as described in the Assembly section.

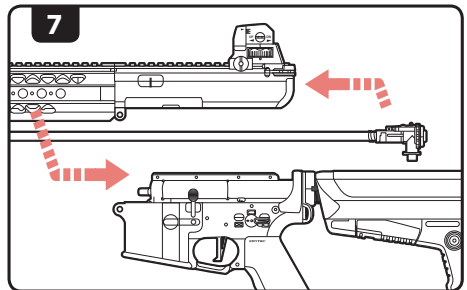

OPERATING UNDER HARSH CONDITIONS

When operating under harsh conditions, special maintenance may be required to match the climate conditions of a specific operational area.

Dust and Sand

In harsh dusty or sandy environments, excessive debris can cause malfunctions and/or excessive wear on parts. Keep the gun covered and protected while not in use. When performing maintenance, use lubrication sparingly as it tends to attract dirt and other particles. After use in a dusty or sandy area, always field strip the gun, as outlined in the Disassembly section, cleaning all the areas that can be reached with a soft, clean, lint-free cloth.

Heavy Rain

Never submerge or expose your gun to extremely wet environments. Exposure to such conditions may cause electrical failure and fluid to build-up inside the gearbox. Dry completely with a clean, lint-free cloth and clean inner barrel when necessary.

HEARING PROTECTION REQUIREMENT

HEARING PROTECTION REQUIREMENT FOR EUROPEAN COMMUNITY
The KRYTAC LVOA-C, LVOA-S fulfill all relevant provisions of:

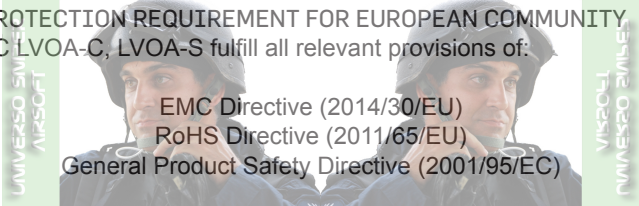

EMC Directive (2014/30/EU)
RoHS Directive (2011/65/EU)
General Product Safety Directive (2001/95/EC)

In conjunction with the following harmonized standards or technical specifications for the design and manufacture

EN 50581:2012; EN 55014-1:2006; EN 55014-2:1997

In accordance with the above mentioned standards, in some applications, noise or vibration levels may exceed the minimum Noise levels of 85db(A). If Noise levels exceed 85dB(A), appropriate ear protection must be used to prevent any damages due to sound emissions.

CONTACT INFORMATION

For additional troubleshooting, information, or questions regarding KRYTAC customer service:

Submit a contact form at: www.krytac.com

Email us at: customerservice@krytac.com

Join the KRYTAC Community and visit <http://forums.krytac.com> for any additional technical questions and information about your KRYTAC.

TROUBLE SHOOTING GUIDE



WARNING

WHEN TROUBLESHOOTING, FOLLOW THE SAFETY MEASURES DESCRIBED IN THIS MANUAL.

SYMPTOMS	CAUSE	SOLUTIONS
Not firing/No sound	Safety is engaged	Change selector to Semi Auto or Full Automatic Mode
	Low power or dead battery	Charge and replace battery
	Blown out fuse	Replace with new fuse
	Loose connection	Contact customer service for professional care
Motor is running but not firing	Inspect magazine	Check if magazine is properly loaded into the gun Ensure magazine is loaded with ammunition Ensure the hi-cap magazine is properly wound
Motor or battery is hot after short use	Damaged battery	Inspect and/or replace battery
	Loose connection terminal	Contact customer service for professional care
Semi-Auto feature not functioning properly	Battery voltage or discharge is too high	Condition or replace battery
Semi-Auto feature not working at all	Disconnecter is not engaged properly	Reset the disconnecter by setting the selector to safe, then to automatic, then to semi
Firing cycle slowing down	Battery is low on power	Charge or replace battery
High pitch or grinding noise	Motor level is not adjusted properly	Contact customer service for professional care
BB travels upward	Hop-Up adjusted too high	Dial down the Hop-Up adjustment
BB travels downward	Hop-Up adjusted too low	Dial up the Hop-Up adjustment
BB double feeding or rolling out of the barrel	Excessive grease or oil in the hopup chamber	Fire at least 200 rounds to eliminate excessive grease from the chamber Clean Hop-Up unit with supplied cleaning rod
	Hop-Up unit is turned off	Turn Hop-Up unit on
Hop-Up unit can't be adjusted	Hop-Up adjustment arm is not set properly	Reset Hop-Up adjustment arm (See page 18, step. 6 for reassembly)
Inner barrel is jammed or jamming	Use of recycled or low quality BBs	Use only KRYTAC branded or other high quality BBs
	Inner Barrel is contaminated with BBs or debris	Clear and/or clean inner barrel with supplied cleaning rod (See page 11 for clearing jam section and page 17 for cleaning and maintenance section)
Hi-Cap magazine not feeding	Magazine has not been wound	Wind wheel underneath magazine
	BBs are lodged inside the magazine	Shake or tap magazine to clear the jam
	Internal obstruction	Contact customer service for professional care

COMPONENT DIAGRAM: LVOA®-C, LVOA®-S

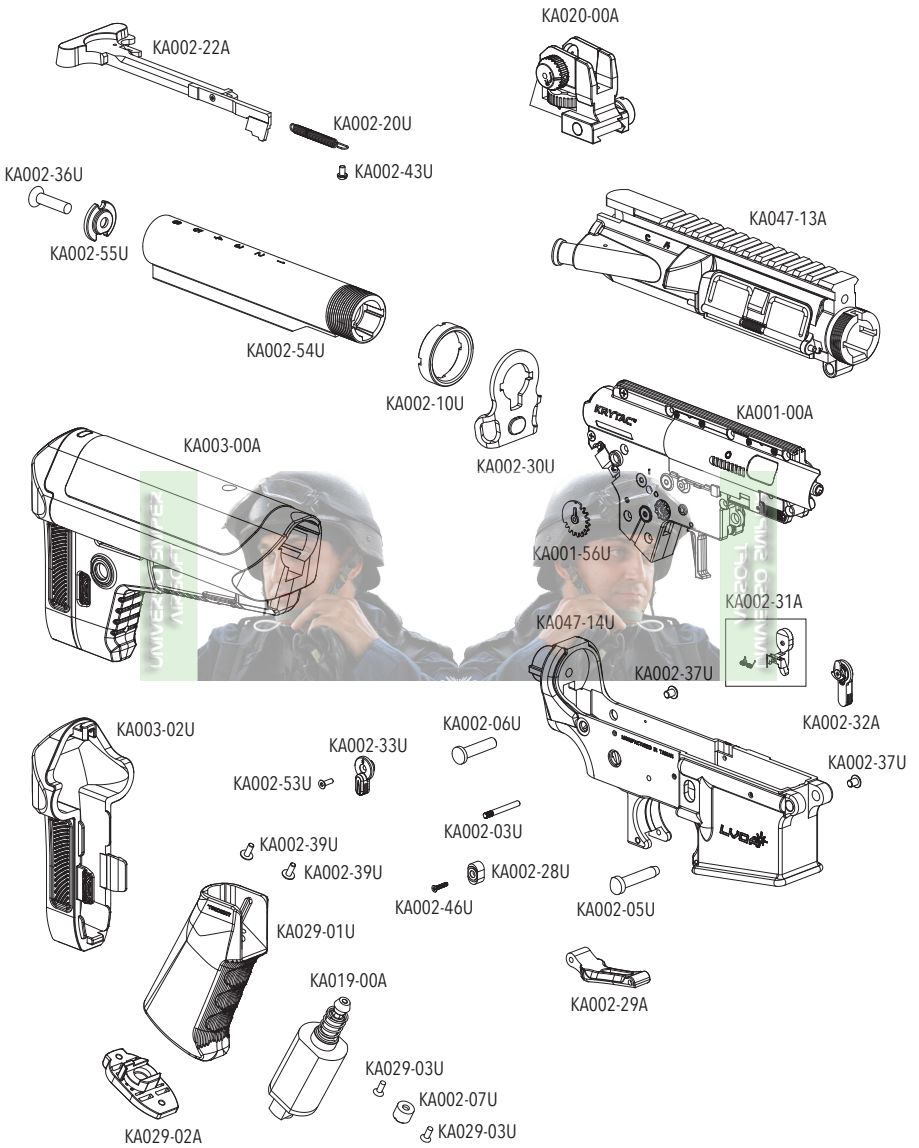

COMPONENT DIAGRAM: LVOA®-C, LVOA®-S

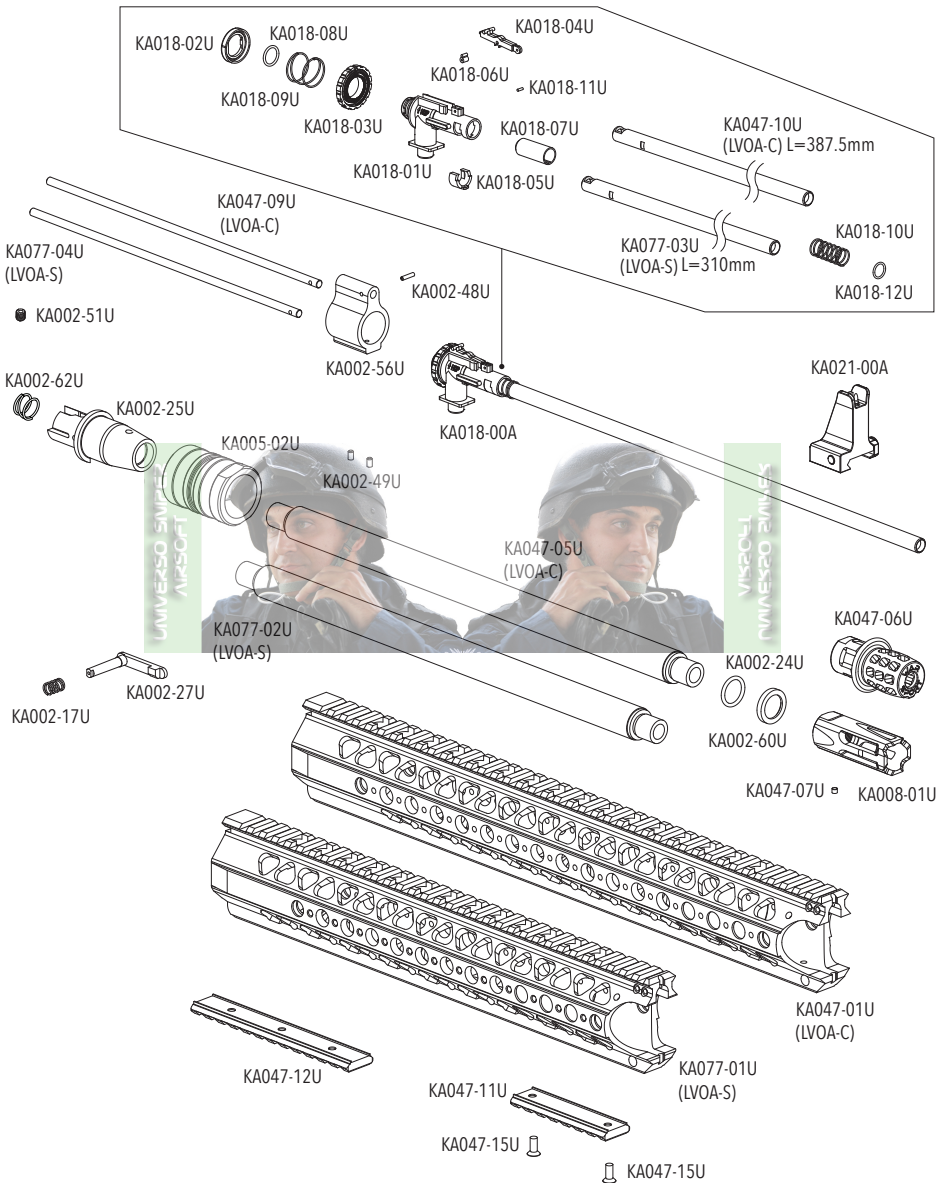

COMPONENT DIAGRAM: GEARBOX

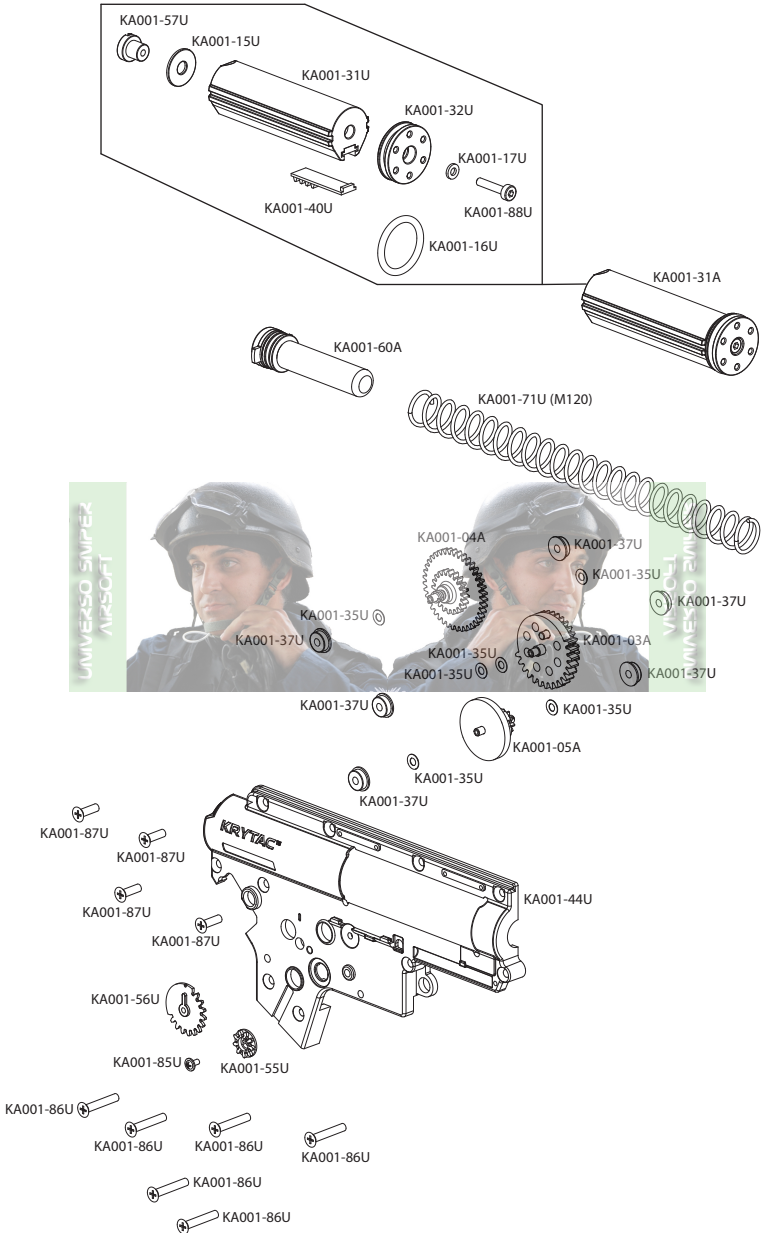

COMPONENT DIAGRAM: GEARBOX

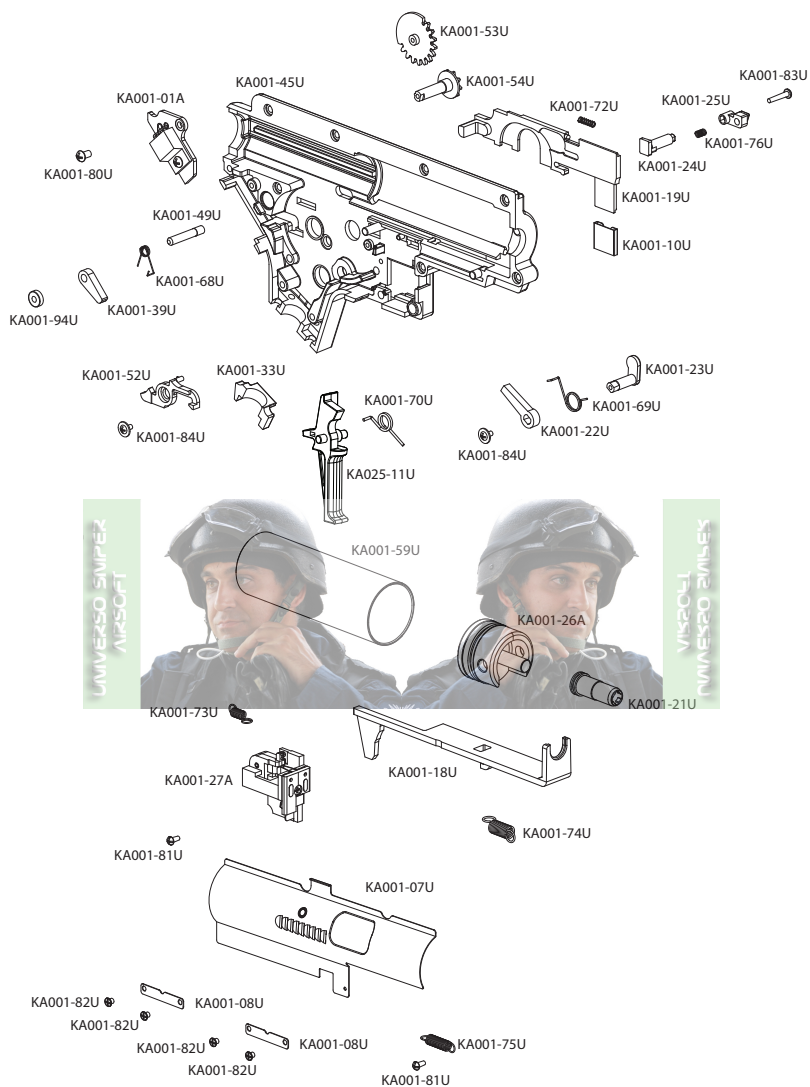

COMPONENT LIST: LVOA[®]-C, LVOA[®]-S

PART #	NAME
KA001-00A	GEARBOX
KA001-01A	MOSFET ASSEMBLY
KA001-03A	SECTOR GEAR
KA001-04A	SPUR GEAR
KA001-05A	BEVEL GEAR
KA001-07U	BOLT PLATE
KA001-08U	BOLT PLATE GUIDE (2)
KA001-10U	CONTACT (SELECTOR)
KA001-15U	MAIN SPRING SHIM
KA001-16U	PISTON HEAD O-RING
KA001-17U	PISTON HEAD SHIM
KA001-18U	TAPPET PLATE
KA001-19U	SELECTOR PLATE
KA001-21U	AIR NOZZLE
KA001-22U	SAFETY BLOCK
KA001-23U	SAFETY BLOCK LEVER
KA001-24U	BOLT PLATE LOCK
KA001-25U	BOLT PLATE LOCK BUTTON
KA001-26A	CYLINDER HEAD ASSEMBLY
KA001-27A	SWITCH ASSEMBLY
KA001-31A	PISTON ASSEMBLY
KA001-31U	PISTON BODY
KA001-32U	PISTON HEAD
KA001-33U	WIRING COVER
KA001-35U	SHIM (6)
KA001-37U	BEARING (6)
KA001-39U	ANTI-REVERSE LATCH
KA001-40U	PISTON TOOTH RACK
KA001-44U	GEARBOX SHELL (RIGHT)
KA001-45U	GEARBOX SHELL (LEFT)
KA001-49U	ANTI-REVERSE LATCH PIN
KA001-52U	DISCONNECT LEVER
KA001-53U	SELECTOR GEAR (LEFT)
KA001-54U	SELECTOR TRANSFER AXIS GEAR
KA001-55U	SELECTOR TRANSFER CAP GEAR
KA001-56U	SELECTOR GEAR (RIGHT)
KA001-57U	PISTON HEAD NUT
KA001-59U	CYLINDER (TYPE 1)
KA001-60A	SPRING GUIDE ASSEMBLY
KA001-68U	ANTI-REVERSE LATCH SPRING
KA001-69U	SAFETY BLOCK SPRING
KA001-70U	TRIGGER SPRING
KA001-71U	MAIN SPRING (M120)
KA001-72U	DISCONNECT SPRING
KA001-73U	SWITCH SPRING
KA001-74U	TAPPET PLATE SPRING
KA001-75U	BOLT RETURN SPRING
KA001-76U	BOLT PLATE LOCK SPRING
KA001-80U	MOSFET SCREW
KA001-81U	BUTTON MICRO SCREW
KA001-82U	BOLT PLATE SCREW (4)
KA001-83U	BOLT PLATE LOCK SCREW
KA001-84U	FLAT MICRO SCREW (2)
KA001-85U	SELECTOR TRANSFER GEAR SCREW
KA001-86U	GEARBOX SHELL SCREW (LONG)(6)
KA001-87U	GEARBOX SHELL SCREW (SHORT)(4)
KA001-88U	PISTON HEAD SCREW
KA001-94U	SOLID STEEL BUSHING
KA002-03U	GEARBOX PIN
KA002-05U	FRONT RECEIVER PIN
KA002-06U	REAR RECEIVER PIN
KA002-07U	MOTOR ADJUSTMENT SCREW
KA002-10U	CASTLE NUT
KA002-17U	MAGAZINE RELEASE SPRING
KA002-20U	CHARGING HANDLE SPRING

COMPONENT LIST: LVOA®-C, LVOA®-S

KA002-22A	CHARGING HANDLE ASSEMBLY	KA018-07U	BUCKING
KA002-24U	CRUSH WASHER O-RING	KA018-08U	ADJUSTMENT RETENSION O-RING
KA002-25U	OUTER BARREL BASE	KA018-09U	ADJUSTMENT SPRING
KA002-27U	MAGAZINE RELEASE	KA018-10U	TENSION SPRING
KA002-28U	MAGAZINE RELEASE BUTTON	KA018-11U	ADJUSTMENT LEVER PIN
KA002-29A	TRIGGER GUARD ASSEMBLY	KA018-12U	FRONT BARREL O-RING
KA002-30U	SLING PLATE	KA019-00A	MOTOR
KA002-31A	BOLT STOP ASSEMBLY	KA020-00A	REAR SIGHT ASSEMBLY
KA002-32A	LEFT SELECTOR ASSEMBLY	KA021-00A	FRONT SIGHT ASSEMBLY
KA002-33U	RIGHT SELECTOR	KA025-11U	TRIGGER
KA002-36U	BUFFER TUBE SCREW	KA029-01U	PISTOL GRIP
KA002-37U	RECEIVER PIN CAP SCREW (2)	KA029-02A	MOTOR PLATE ASSEMBLY
KA002-39U	PISTOL GRIP SCREW (2)	KA029-03U	MOTOR PLATE SCREW (2)
KA002-43U	CHARGING HANDLE ANCHOR SCREW	KA047-01U	LVOA®-C RAIL
KA002-46U	MAGAZINE RELEASE SCREW	KA047-05U	OUTER BARREL (LVOA®-C)
KA002-48U	GAS BLOCK PIN	KA047-06U	WAR SPORT TOP HAT FLASH HIDER
KA002-49U	GAS BLOCK SCREWS (2)	KA047-07U	SET SCREW
KA002-51U	OUTER BARREL BASE SCREW	KA047-09U	GAS TUBE (LVOA®-C)
KA002-53U	RIGHT SELECTOR SCREW	KA047-10U	INNER BARREL (LVOA®-C)
KA002-54U	BUFFER TUBE	KA047-11U	LVOA SHORT RAIL
KA002-55U	BUFFER TUBE SCREW CAP	KA047-12U	LVOA LONG RAIL
KA002-56U	GAS BLOCK	KA047-13A	UPPER RECEIVER
KA002-60U	CRUSH WASHER	KA047-14U	LOWER RECEIVER
KA002-62U	HOP-UP TENSION SPRING	KA047-15U	LVOA RAIL SCREWS
KA003-00A	STOCK ASSEMBLY	KA077-01U	LVOA®-S RAIL
KA003-02U	BUTTPAD	KA077-02U	OUTER BARREL (LVOA®-S)
KA008-01U	FLASH HIDER	KA077-03U	INNER BARREL (LVOA®-S)
KA018-00A	HOP-UP CHAMBER ASSEMBLY	KA077-04U	GAS TUBE (LVOA®-S)
KA018-01U	HOP CHAMBER		
KA018-02U	ADJUSTMENT CAP		
KA018-03U	ADJUSTMENT WHEEL		
KA018-04U	ADJUSTMENT LEVER		
KA018-05U	BARREL CLIP		
KA018-06U	NUB		



UNIVERSO SIMPER
AIRSOFT

www.krytac.com

© Copyright 2015
KRISS INDUSTRIES ASIA
Subject to change

V.MLTY01 R.2016.05.31

CE

VISPOL
UNIVERSO EMILEX