

HVWA[®]

AEG³
RM4
SERIES

OPERATOR'S MANUAL



UNIVERSO SMIPER
AIRSOFT

UNIVERSO SMIPER
AIRSOFT

TABLE OF CONTENTS

Warranty	3-4
Use of this Manual.....	5
Safety Guidelines	5-6
Specifications and Package Contents:	
RM4A1	7
Battery Installation and Fuse	8
Loading BBs	9
Using KWA High Performance BB Loader	10
Loading Magazine	11
Fire Selector Switch.....	11
Front and Rear Sight Adjustment	12
Disassembly.....	13
Assembly	13
Cleaning	14
Hop Up System	15-16
Auto Cutoff	16
Troubleshooting	17
Operating Under Unusual Conditions	17
Diagram and Parts Lists:	
RM4A1 Parts Diagram	18-19
RM4A1 Parts List	20-21
RM4 AEG 3 Gearbox Parts List	22



KWA[®]

WARRANTY

KWA PERFORMANCE INDUSTRIES, INC.

18571 E. Gale Ave.

City of Industry, CA 91748

(626) 581-1777

store.kwausa.com

THANK YOU FOR PURCHASING A KWA PERFORMANCE INDUSTRIES, INC. PRODUCT. KWA Performance Industries, Inc. is committed to serving our customers with the finest quality products, the highest level of service, and the best customer satisfaction. Because of this, we offer a 90 day warranty on all KWA products we import and distribute.

Warranty Coverage

Except as specified below, this warranty covers all defects in material and workmanship in KWA products that occur during the above warranty period. The following are not covered by the warranty: (1) Any product which is not imported and distributed in the U.S.A. by KWA PERFORMANCE INDUSTRIES, INC. (2) Any products not purchased in the U.S.A. from a KWA AUTHORIZED RESELLER. If you are uncertain as to whether a reseller is a KWA AUTHORIZED RESELLER, please contact KWA PERFORMANCE INDUSTRIES, INC. as listed above or visit our website www.kwausa.com/storefinder. (3) Damages, deterioration, or malfunction resulting from: a) An accident, act of nature, abuse, misuse, neglect, opening of mechbox, or failure to follow instructions supplied with the product. b) Repair or attempted repair by anyone not authorized by KWA PERFORMANCE INDUSTRIES, INC. c) Removal of the orange safety tip. (4) Use of the product outside the U.S.A. (5) Damaged batteries or improper use of bullets (BBs), or non approved propellants (ie. Propane, Red Gas, 134a...etc.) (6) Use in industrial, commercial, and/or professional applications.

What KWA Will Pay For

If your KWA product is found to be defective by KWA Performance Industries, Inc. during the applicable warranty period from the date of original purchase, KWA Performance Industries, Inc. will repair, or at its option, replace with new, used, or equivalent model, the defective product without charge for parts or labor.

How To Obtain Warranty Service

If your product needs service, it may be taken or shipped to KWA Performance Industries, Inc. The following procedures apply whenever your unit must be transported for warranty service:

- You must go to the RMA Request Quick Link at www.kwausa.com to obtain an RMA number. THE RMA NUMBER MUST BE CLEARLY MARKED ON THE OUTSIDE OF THE PACKAGE. PACKAGES WITHOUT AN RMA NUMBER CLEARLY MARKED WILL BE REFUSED AND RETURNED TO THE SENDER.
- You are responsible for transporting your unit or arranging for its transportation.
- If shipment of your unit is required; you must pay the initial shipping fee, but we will pay the return shipping charge if the repairs are covered by the warranty.
- WHEN RETURNING YOUR UNIT FOR WARRANTY SERVICE, A COPY OF THE ORIGINAL SALES RECEIPT MUST BE ATTACHED.
- You must include the following: RMA number, your name, address, daytime telephone number, model and serial number (if applicable) of the product and a description of the problem.

This Warranty is Only Valid in the United States

If your product does not require service, but you have questions regarding its operation, please contact our Help Desk at www.kwausa.com.

THIS WARRANTY IS EXPRESSLY MADE IN LIEU OF ALL OTHER WARRANTIES, EXPRESSED OR IMPLIED, INCLUDING WITHOUT LIMITATION, WARRANTIES OF MERCHANTABILITY AND FITNESS FOR A PARTICULAR PURPOSE.

OUR LIABILITY IS LIMITED TO THE REPAIR OR REPLACEMENT, AT OUR OPTION, OF ANY DEFECTIVE PRODUCT AND SHALL IN NO EVENT INCLUDE INCIDENTAL OR CONSEQUENTIAL COMMERCIAL OR PROPERTY DAMAGES OF ANY KIND. WE ARE NOT RESPONSIBLE FOR PRODUCTS LOST, STOLEN AND/OR DAMAGED DURING SHIPPING.

SOME STATES DO NOT ALLOW LIMITATIONS ON HOW LONG AN IMPLIED WARRANTY LASTS AND/OR DO NOT ALLOW THE EXCLUSION OF INCIDENTAL OR CONSEQUENTIAL DAMAGES, THE ABOVE LIMITATIONS AND EXCLUSIONS MAY NOT APPLY TO YOU.

This warranty gives you specific legal rights, but you may also have other rights which vary from state to state. This warranty may not be altered other than in writing signed by an officer of KWA Performance Industries, Inc.

USE OF THIS MANUAL

Before operating the Airsoft gun, read this manual in its entirety. Important safety topics and tips are discussed throughout all of the chapters. It's important that the operator know the principles of gun handling, safety, and operation prior to firing the Airsoft gun.

SAFETY GUIDELINES

Safety Distance

The effective shooting range is approximately 175 feet. BBs fired from this Airsoft gun may travel farther than intended. Make certain that you have an adequate backstop.

Eye Protection

Eye protection should be worn at all times when both shooting and maintaining your Airsoft gun. Protect your eyes from BBs under pressure while performing maintenance on your Airsoft gun.

Assume Every Gun is Always Loaded

Until you are certain the chamber is empty, treat every gun as if it were loaded. Do not assume the chamber is empty based on your memory or someone else's word. Always remove the magazine and visually check to confirm the chamber is empty.

Beware of Barrel Obstructions

Ensure the Airsoft gun barrel is free of obstructions before you fire the gun. Even the smallest obstruction such as dirt, dust, or a stuck cleaning patch can cause a jam, misfire, or malfunction.

Muzzle Control

Always keep the muzzle of the gun pointed in a safe direction. Never point the muzzle at a person or object that you do not intend to shoot.

Keep Your Safety On

Keep the gun's safety on until your sights are aligned on your target and you are ready to fire.

Keep Your Finger Off The Trigger

Keep your finger off the trigger and out of the trigger guard until your sights are aligned on your target and you are ready to fire.

Identify Your Target and Backstop

Before you pull the trigger, make certain of your target and what is beyond it. The Airsoft gun should never be fired at surfaces such as rocks, glass, water, or other hard surfaces where BBs are likely to ricochet in unpredictable directions.



WARNING:

- Airsoft BBs can be a choking hazard. Keep them away from children.
- Failure to follow safety guidelines may result in serious injury.

SAFETY GUIDELINES (CONTINUED)

Failure To Fire

If the Airsoft gun fails to fire, misfires, or malfunctions, do not look into the gun barrel. BBs can become lodged into the chamber, and serious eye injury may occur.

Maintain Your Gun Properly

Performing proper maintenance, as outlined in this manual, ensures that your Airsoft gun will be safe to shoot and will perform to its designed specifications for many years. Alterations, modifications or adjustments may damage your Airsoft gun, make it unsafe to shoot, and will void all warranty claims.

Store Your Gun Safely

Always store the Airsoft gun in a safe place, and out of reach of children. Always transport the Airsoft gun in a carrying case. Never display the Airsoft gun in a public place. Keep the safety engaged, and remove the magazine before storing the Airsoft gun.

NOTE: IT IS YOUR RESPONSIBILITY TO TAKE EVERY REASONABLE PRECAUTION TO ENSURE THE SAFE STORAGE AND TRANSPORTATION OF YOUR AIRSOFT GUN.

Orange Tip

The orange tip on Airsoft guns help Law Enforcement distinguish the replica guns from their real firearm counterparts. Altering the coloration or markings required by state or Federal law so as to make the product look more like a firearm is dangerous and may be a crime. Operator assumes all risks and responsibility when doing so.

Hazards of Being Mistaken for a Real Firearm

Airsoft guns have been mistaken by Police and Law Enforcement as real firearms. A confrontation with law enforcement while carrying an Airsoft gun can result in serious injury or even death. It is strongly advised to operate the Airsoft gun at a safe and legal location. In the event that you are approached by Law Enforcement personnel, you must comply with their instructions immediately to avoid an incident.

Alcohol, Medications, and Drugs

Do not handle or operate your Airsoft gun while under the influence of alcohol, medication or drugs.

Your Responsibility

Your Airsoft gun is well-engineered and manufactured to the highest standards. It was carefully inspected before it was packaged and shipped from our factory. Its safe use depends on you alone. You are the ultimate safety device. Like many other devices, your Airsoft gun is safe unless handled in an irresponsible or uneducated manner.



WARNING:

- Adult supervision is required for any person under the age of 18.

SPECIFICATIONS: RM4A1

- Overall Length [Retracted] = 831.9 mm (32.8")
- Overall Length [Extended] = 901.7 mm (35.5")
- Outer Barrel Length = 374.7 mm (14.8")
- Inner Barrel Length = 396.9 mm (15.6")
- Inner Barrel Diameter = 6.05 mm
- Weight (without magazine) = 3.27 kg (7.2 lbs)
- Barrel thread = -14 mm
- Caliber = 6 mm
- Magazine Capacity = 30/120 rounds
- Rate of Fire = 19+ RPS
- Velocity = 390-410 FPS
- Energy Output with 0.20g BB = 1.20 Joules
- Power Source: 9.6v NiMh, 7.4v or 11.1v 15c Li-Po

*Individual test results may vary depending on brand of BBs, ambient temperature, and chronograph used.

Special Features:

- Simulated Recoil
- Polymer Enhanced PTS® Grip
- Switch Life Extender
- Rotary Hop Up
- Magazine Cutoff Compatibility
- Quick Change Spring System
- Reinforced Radiused Mechbox
- KWA 2G High Performance Bucking
- Rear Wired Battery Compartment
- Full Metal Alloy One-Piece Upper Receiver
- Realistic Construction and field Stripping
- Mechanical/Electric Cutoff System



BATTERY INSTALLATION



WARNING: Stock must be fully collapsed before opening the stock cover. Do not remove the stock completely from the gun, doing so will disconnect the terminals inside

1. Set fire selector to safe mode. Place the safety cap on the barrel end. Gently pull the butt plate release tabs to remove the cover.
- 2a. Two types of batteries can be used, Nunchuck batteries and small Li-Po pack batteries. When using a Nunchuck battery, first place the battery into the stock, then push the connector plugs together firmly until they click into place.
- 2b. When using a small Li-Po pack battery, place the battery into the butt plate. Push the connector plugs together firmly until they click into place. *Make sure the small Li-Po pack battery size is no larger than 4"H x 1.25"W x 0.62"D
3. Replace the butt plate by pressing it onto the stock until the retention tabs on the side snap into place.

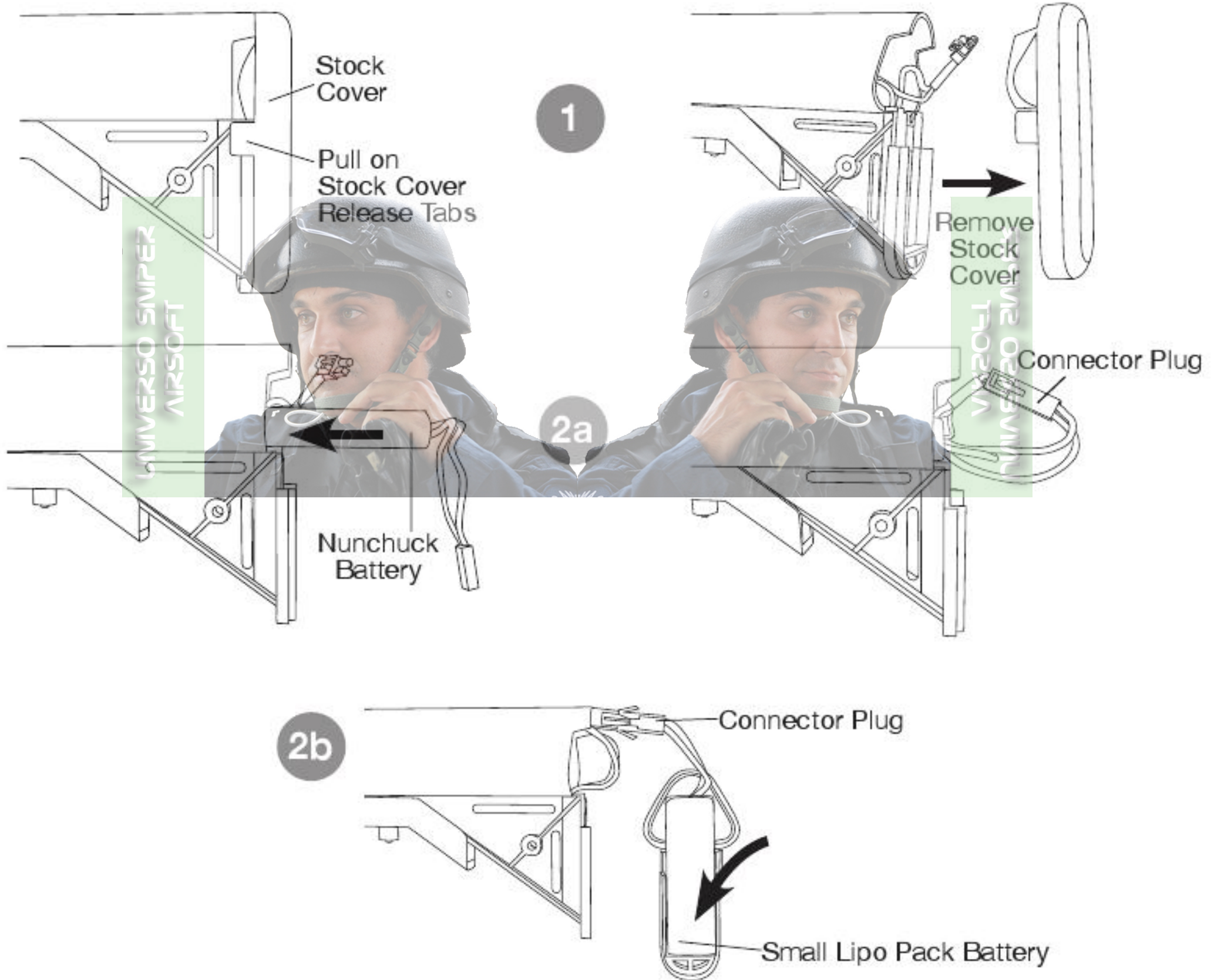

FUSE

To replace the fuse, remove the butt stock cover and replace fuse with up to 20A glass fuse.

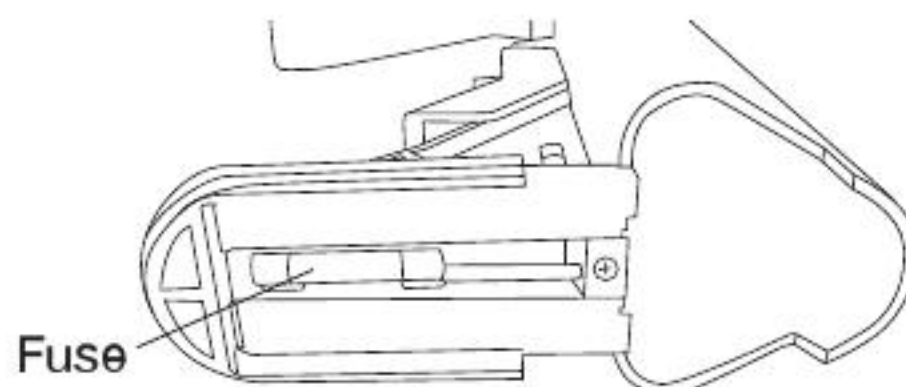

The magazine included with each RM4A1 has an adjustable capacity of 30 or 120 rounds. To switch the magazine capacity, first make sure the magazine is **completely empty**. Then, switch the lever on the bottom of the K120c magazine to the desired capacity as shown.

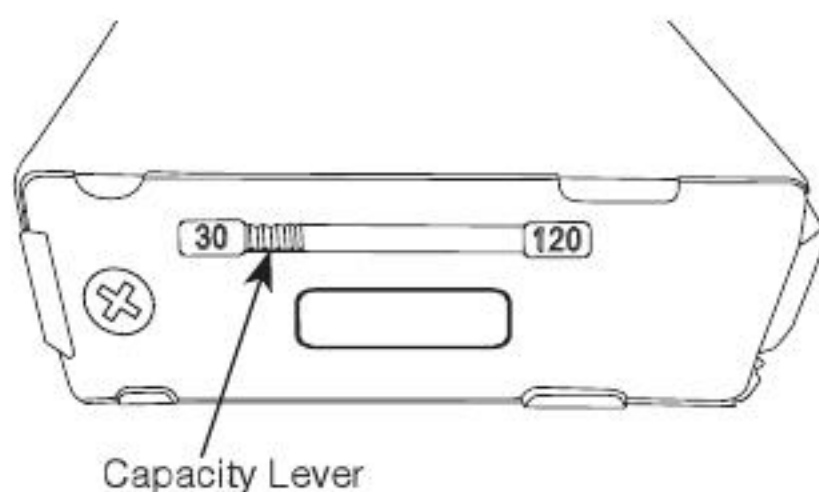

LOADING BBS

1. Release the magazine from the Airsoft gun by pressing the magazine release button.
2. Feed the BBs into the magazine through the magazine feed lip as shown.

****NOTE:** The use of a BB loader, such as the KWA High Performance BB Loader, can help make the loading process easier and faster. (See page 11)

Loading safety tips:

- Switch the selector to safe
- Be sure the safety cap is on
- Keep your finger off the trigger at all times

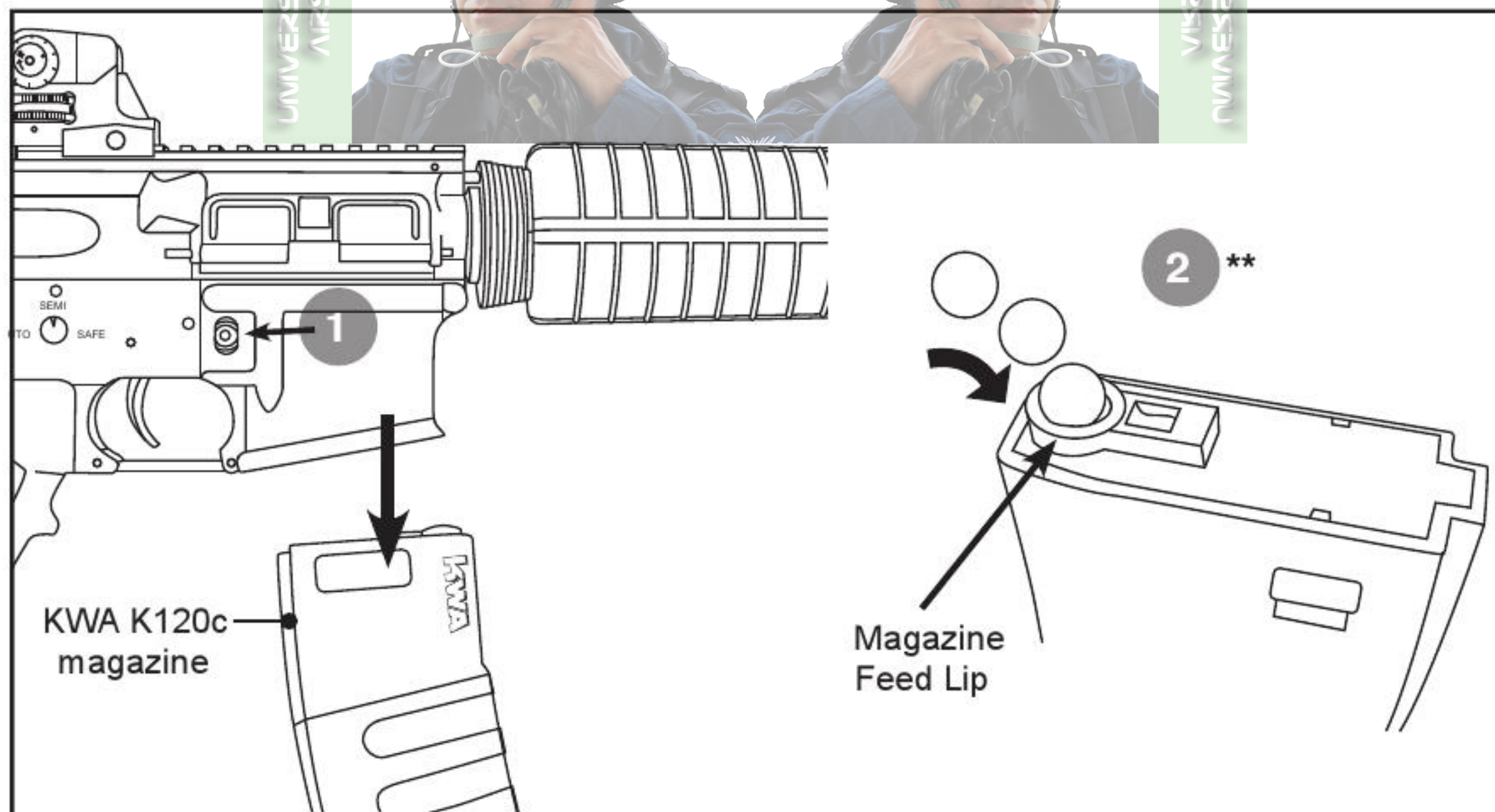

WARNING:

- Always use high quality 6mm BBs, weighing 0.2g or heavier. For best results use 0.25g KWA Perfect BBs. To prevent damage to your gun, avoid using recycled or low grade BBs.

USING KWA HIGH PERFORMANCE BB LOADER (Purchase Separately)

1. Slide open the trap door on top of the BB loader. Fill the BB loader with BBs.
*Do Not Overfill.
2. Flip down the nozzle cover to reveal the loading nozzle.
3. Fit BB loader into the magazine feed lip.
4. Press on BB loader plunger to load BBs into magazine.

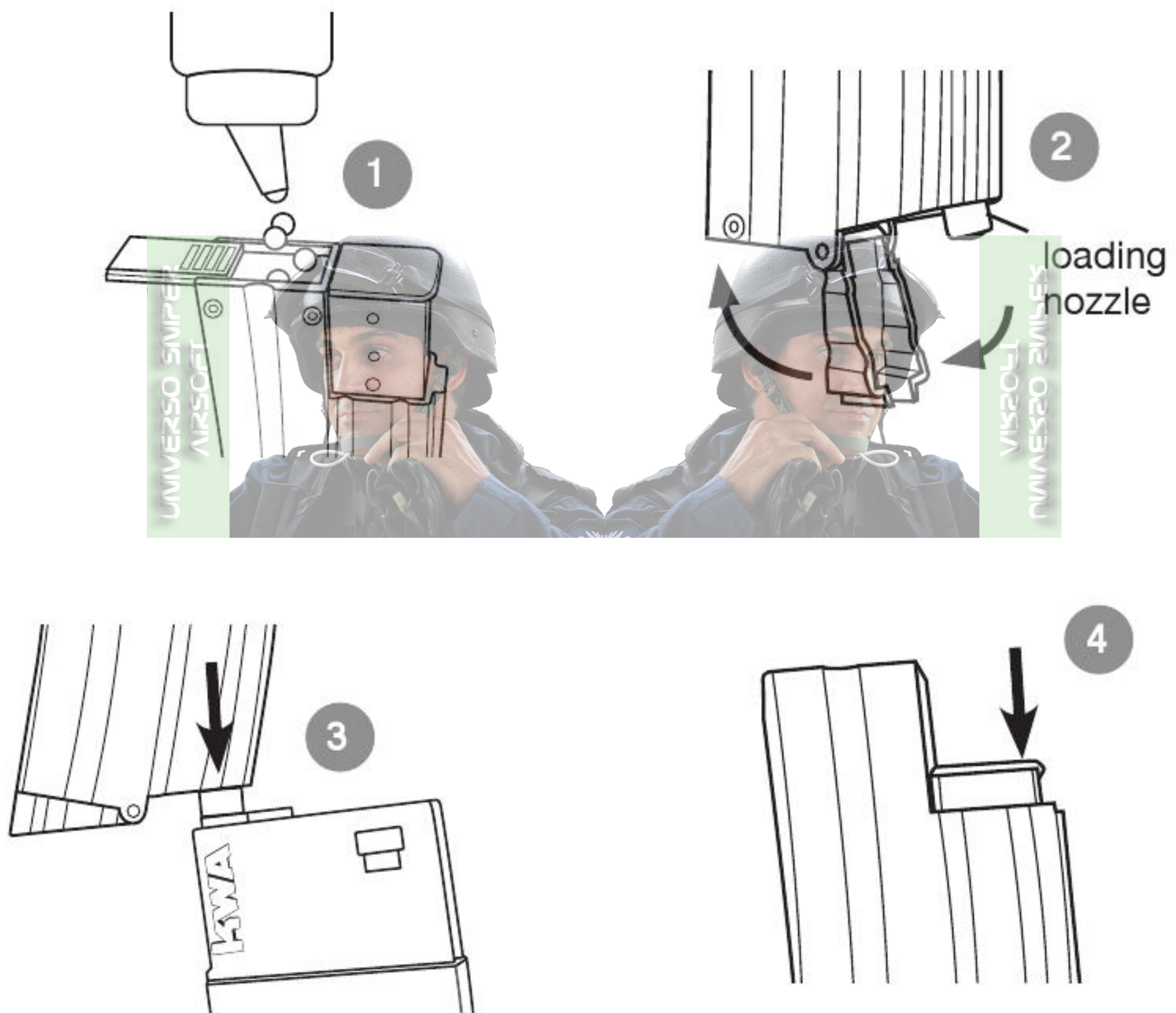

! - KWA K120c magazines hold 30 or 120 rounds of BBs. **DO NOT** load more than 120 rounds into the magazine. Overloading will cause jamming issues.

LOADING MAGAZINE

1. Place the loaded magazine into the magazine well.
2. Lightly pull on the magazine to ensure it is locked in properly.

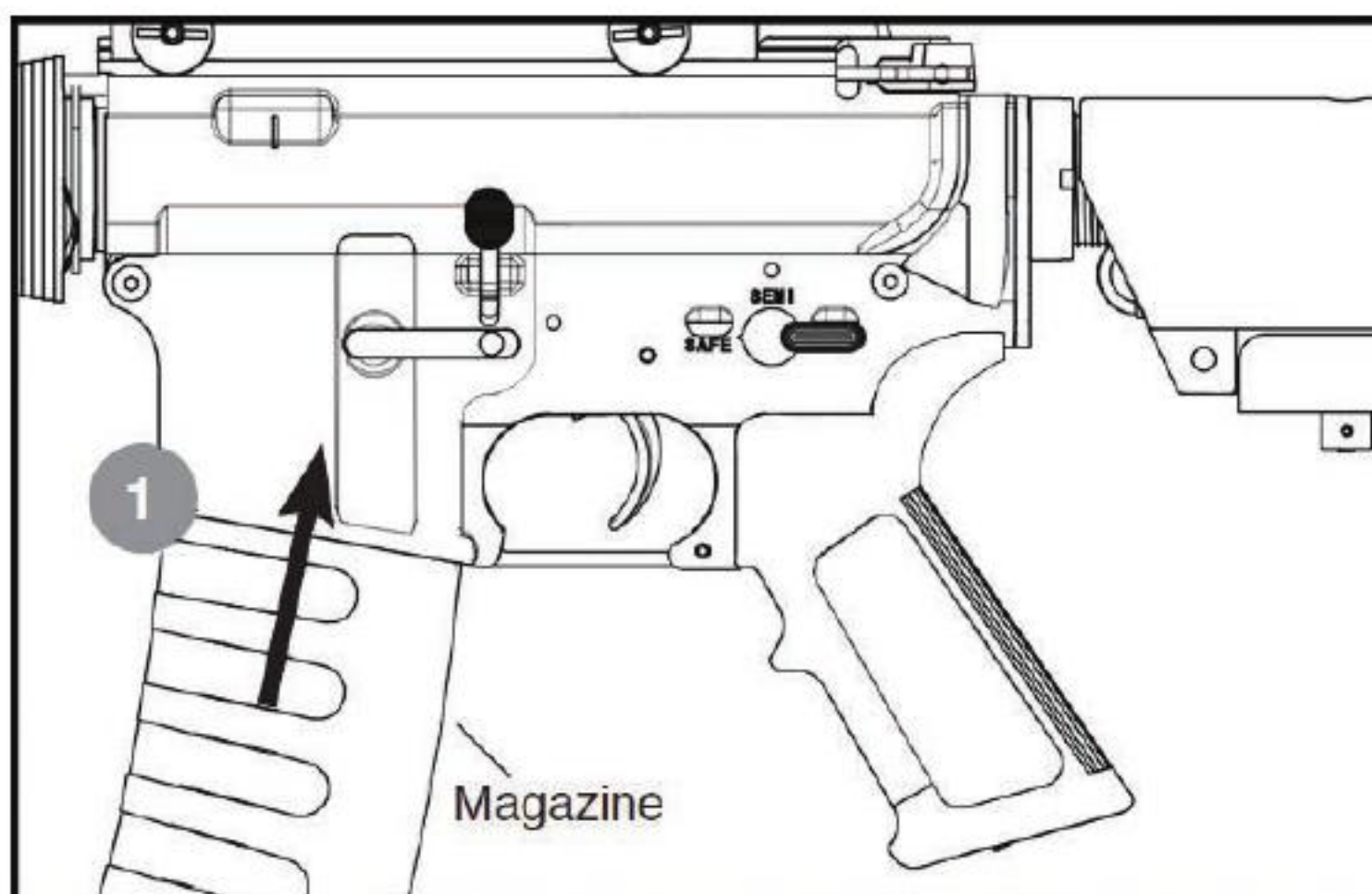

FIRE SELECTOR SWITCH

1. Safe

Safe mode is the setting to the left as indicated in the diagram. In this mode the gun will not fire. For safety reasons, you should keep the switch in Safe mode at all times when you are not ready to fire.

2. Semi-Auto

Semi-Auto mode is the middle setting. In this mode the gun will fire one shot for each time you squeeze the trigger.

3. Full-Auto

Full-Auto mode is the setting to the right. In this mode the gun will fire continuously as long as the trigger is engaged.

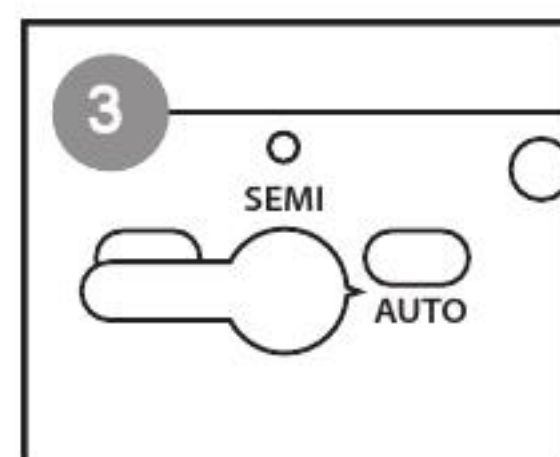
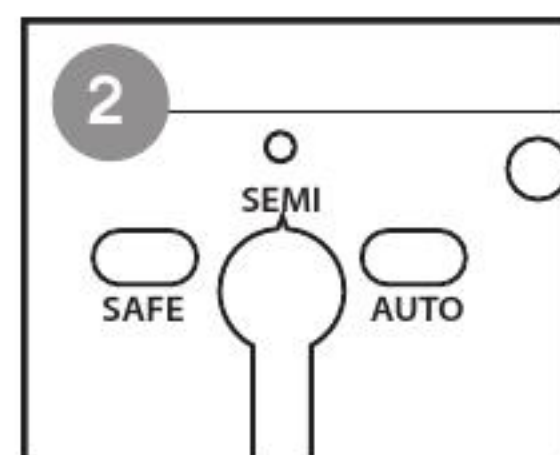
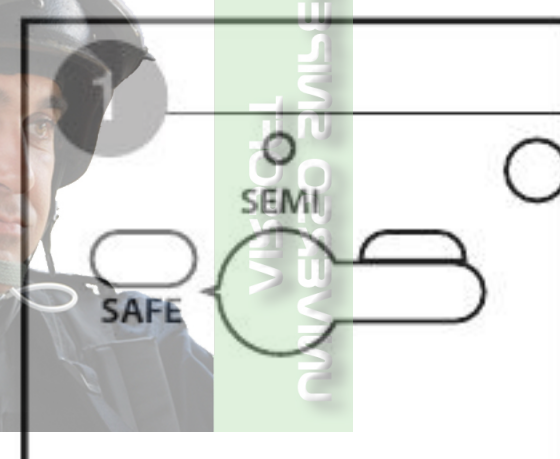

WARNING:

- Do not squeeze the trigger when switching the fire selector.

FRONT AND REAR SIGHT ADJUSTMENT

FRONT SIGHT ADJUSTMENT

1. The front sight can be moved up and down to zero the sights.
2. Turn counter clockwise to raise the post.
3. Turn clockwise to lower the post.

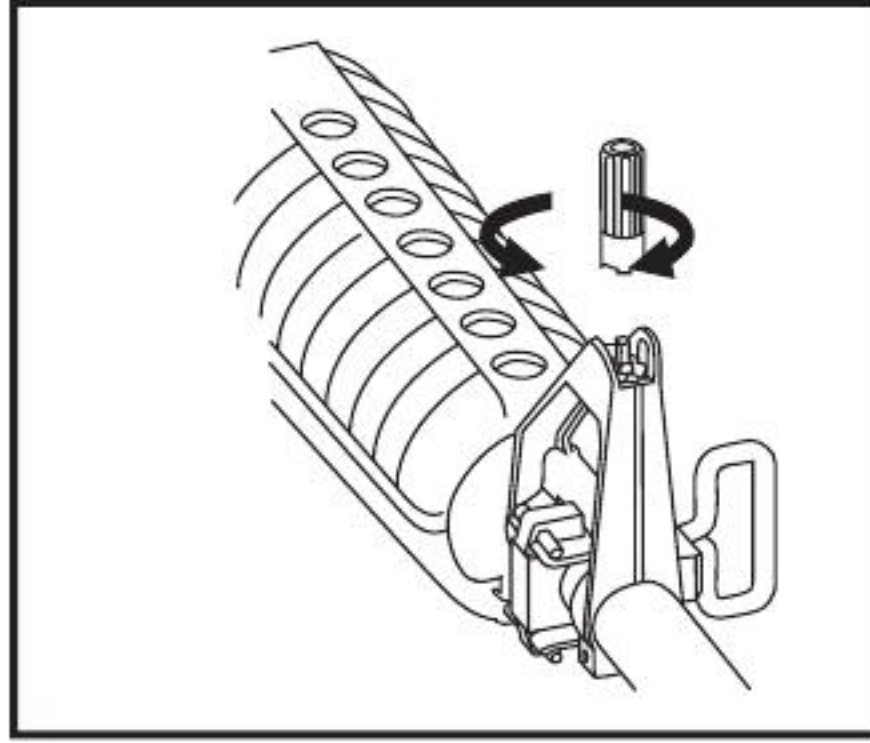

REAR SIGHT ADJUSTMENT

1. Flip the rear sight between general and precision aiming.
2. To adjust the horizontal point of impact, rotate the windage knob located on the rear of the sight.
3. To adjust the vertical point of impact, rotate the sight elevation knob located on the left and right side of the sight.

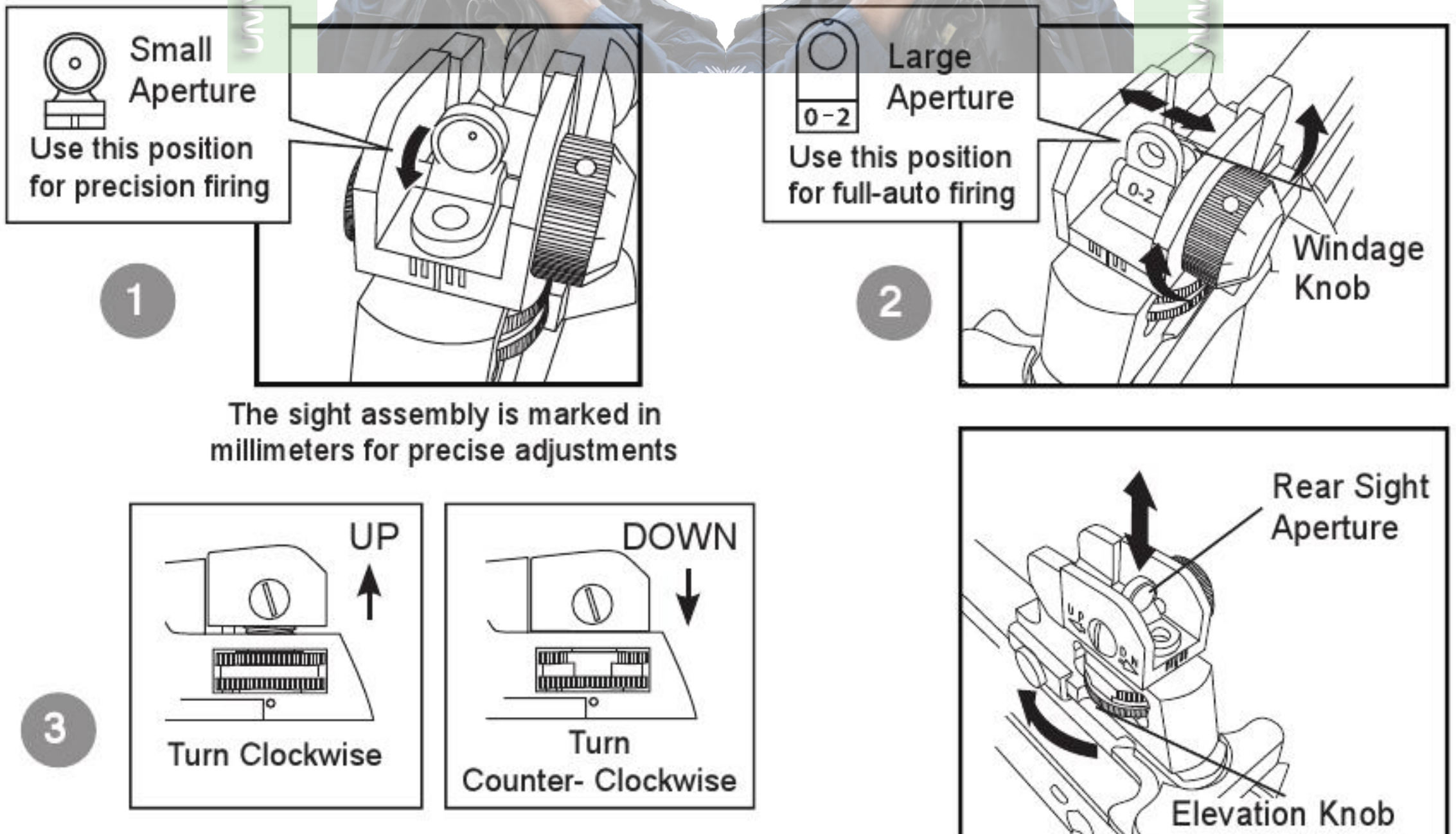

! WARNING:

-If turned too far, the front sight will come off.

DISASSEMBLY

Note: Before opening the receiver, the piston must be in the forward position.

1. Shoot in semi-automatic mode 2-3 times to clear the barrel and reset the piston.
2. Push the front and rear body pins out of place. Both the front and rear pins are captive and will stay in the receiver when pushed all the way out, protruding from the right side of the receiver.
3. Slide the upper receiver forward carefully, making sure that the ejector port cover is manually raised slightly so it does not interfere with the protruding body pin. Also note that the mock bolt plate and charging handle are secured to the gearbox of the AEG 3.
4. Slide out the inner barrel with hop up assembly.

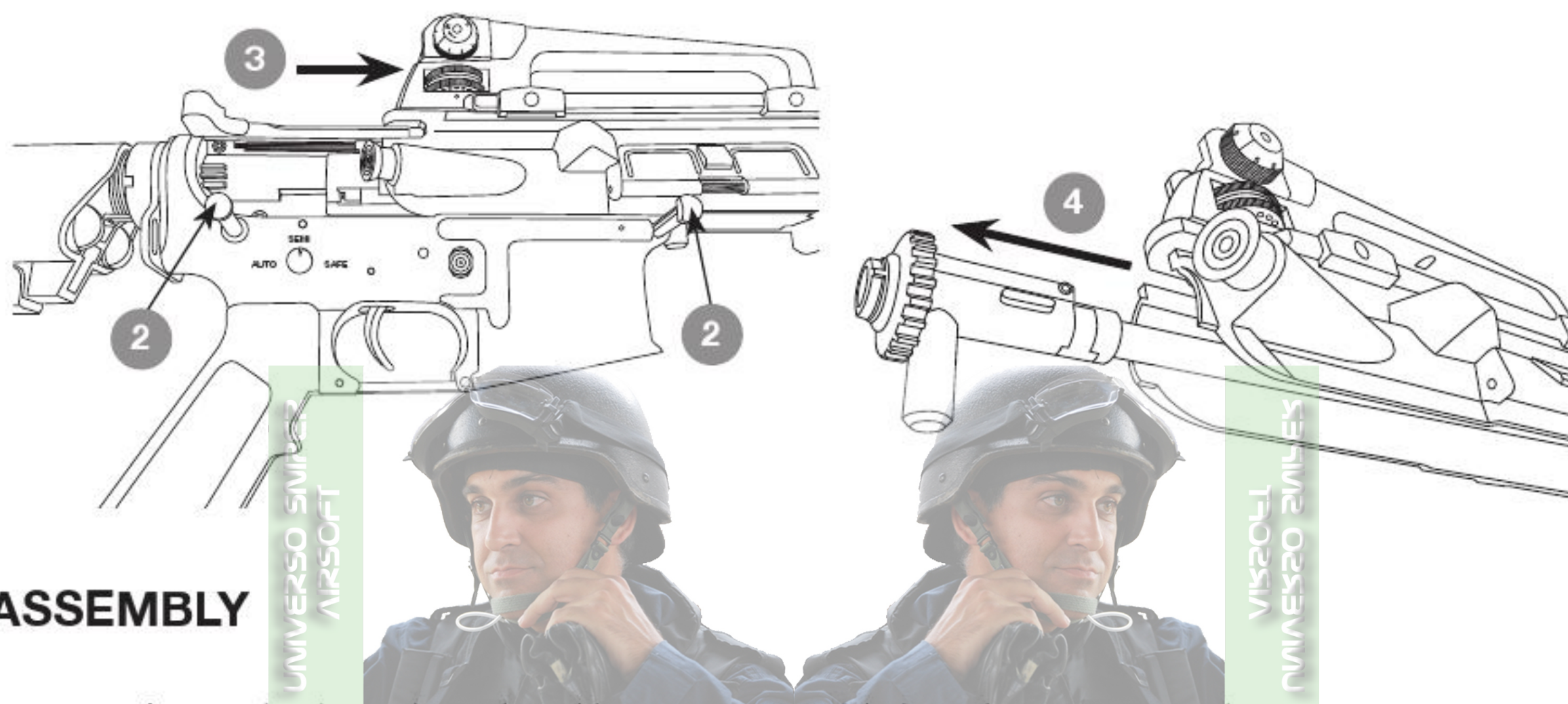

ASSEMBLY

1. Insert the inner barrel and hop up assembly into the upper receiver.
2. Align the upper receiver with the lower receiver and slide them closed, making sure that the bolt plate, charging handle, and bolt release button do not get damaged.
3. Align the pin holes and push the front and rear pins back into place.

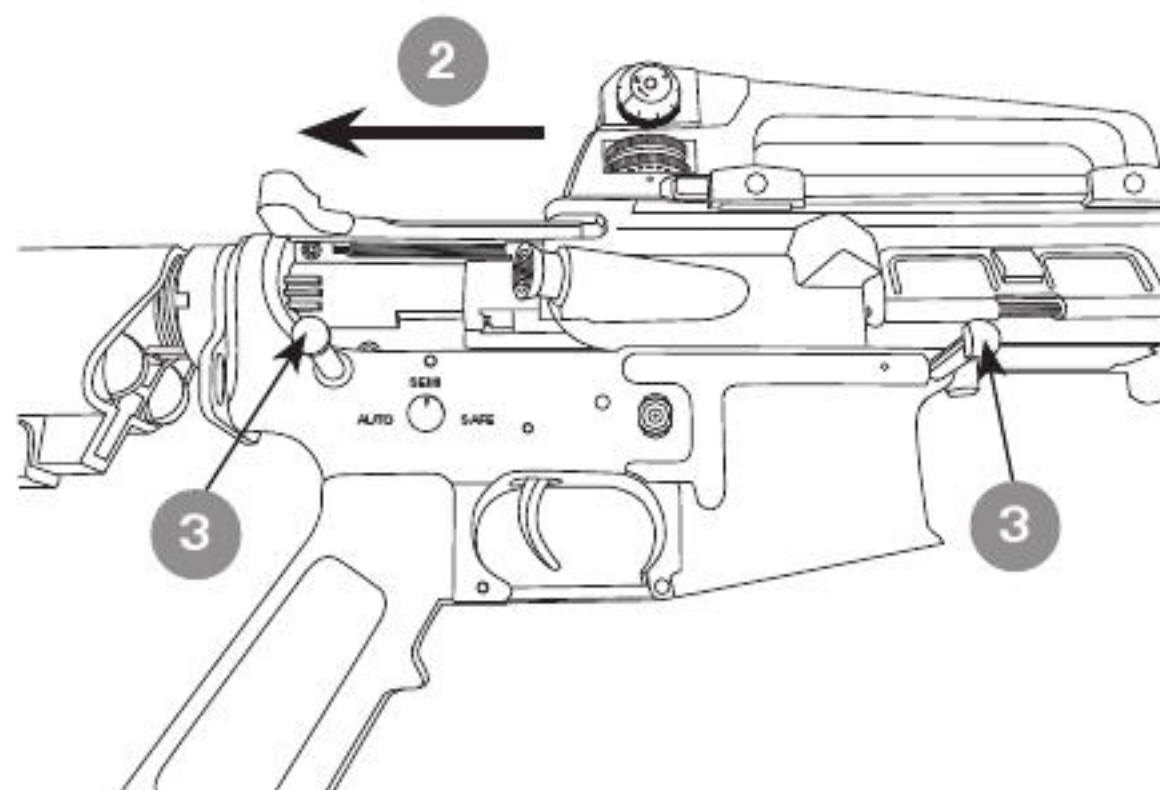

WARNING:

- Always place the safety cap on the barrel tip when servicing your gun. Be sure the fire selector is set to "SAFE".
- If the receiver does not open, repeat step 2 as necessary.

CLEANING

The brass inner barrel should be cleaned after each shooting session. Regular cleaning prevents the effects of BB residue buildup that can hinder performance.

1. Ensure that the safety is engaged.
2. Remove the magazine and clear the chamber of loaded BBs.
3. Disassemble the receiver (see Disassembly section pg. 13).
4. Steps to use cleaning rod:
 - a. Cut a piece of clean cotton cloth to 1 inch by 0.5 inch size. Insert one end of the cloth into the hole in the cleaning rod (adjust the length of cloth for smooth entry into the barrel).
 - b. Wind the cloth around the cleaning rod.
 - c. Insert the cleaning rod into the inner barrel, and push the rod through.
 - d. Remove the cleaning rod and check the cotton cloth for dirt. Repeat a-c when necessary.

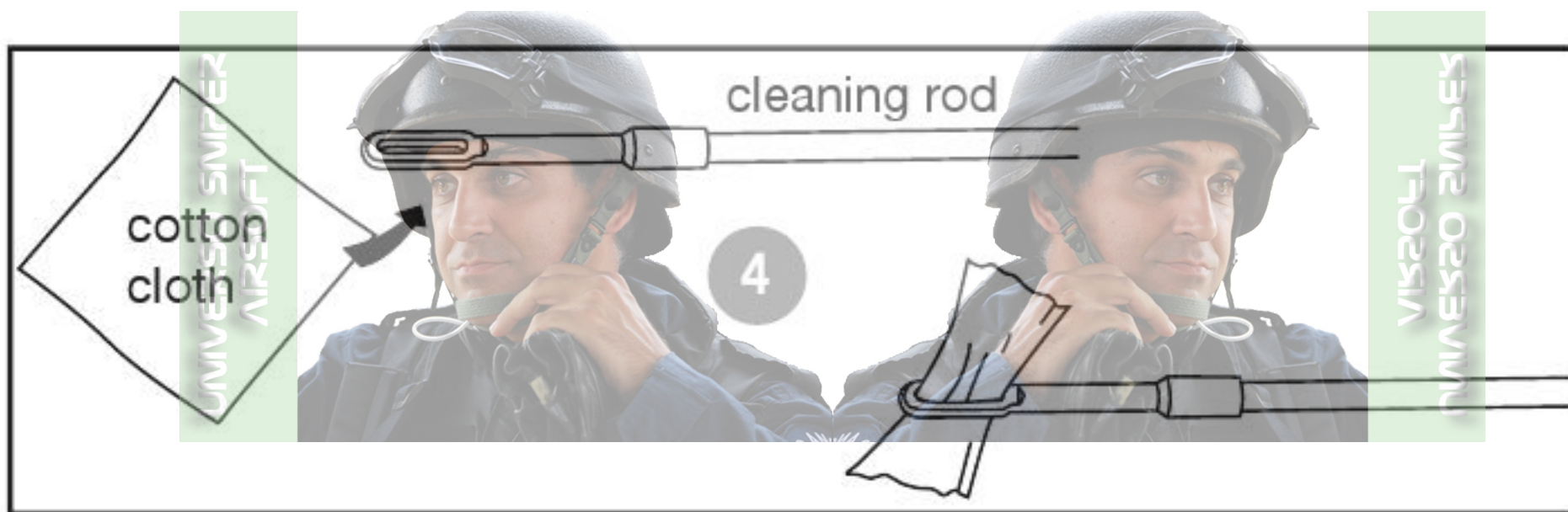

WARNING:

- Unload and clear the Aisoft gun before cleaning.
- **DO NOT** use spray silicone oil as a cleaning solution for the inner barrel.

HOP UP SYSTEM

The hop up device is one of KWA's standard features, giving Airsoft BBs greater stability, farther travel, and increased accuracy. Airsoft BBs are lightweight and can be affected by wind when fired. With the hop up system, the trajectory of the Airsoft BBs can be adjusted according to the shooting environment.







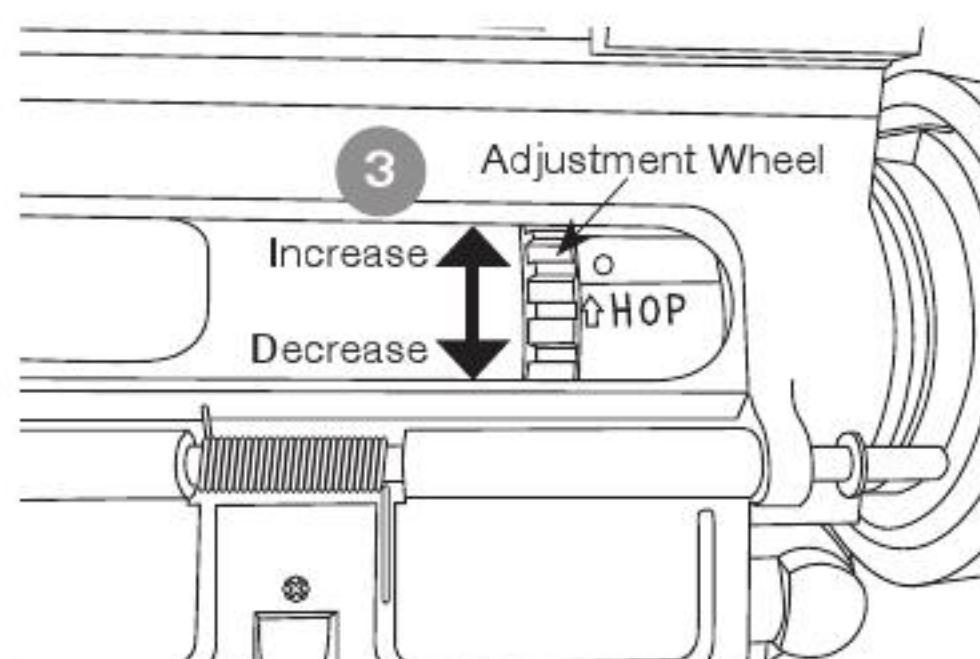
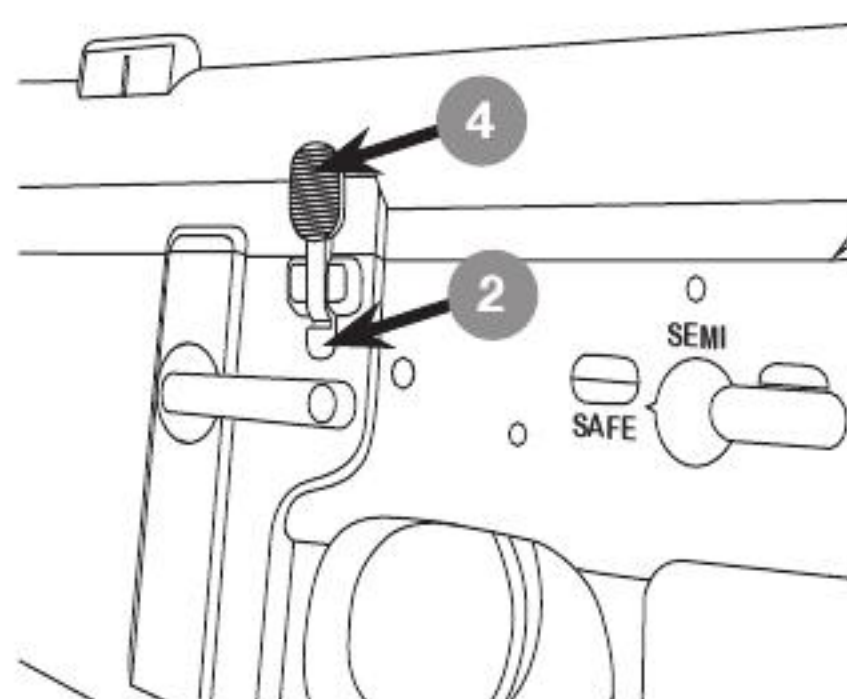
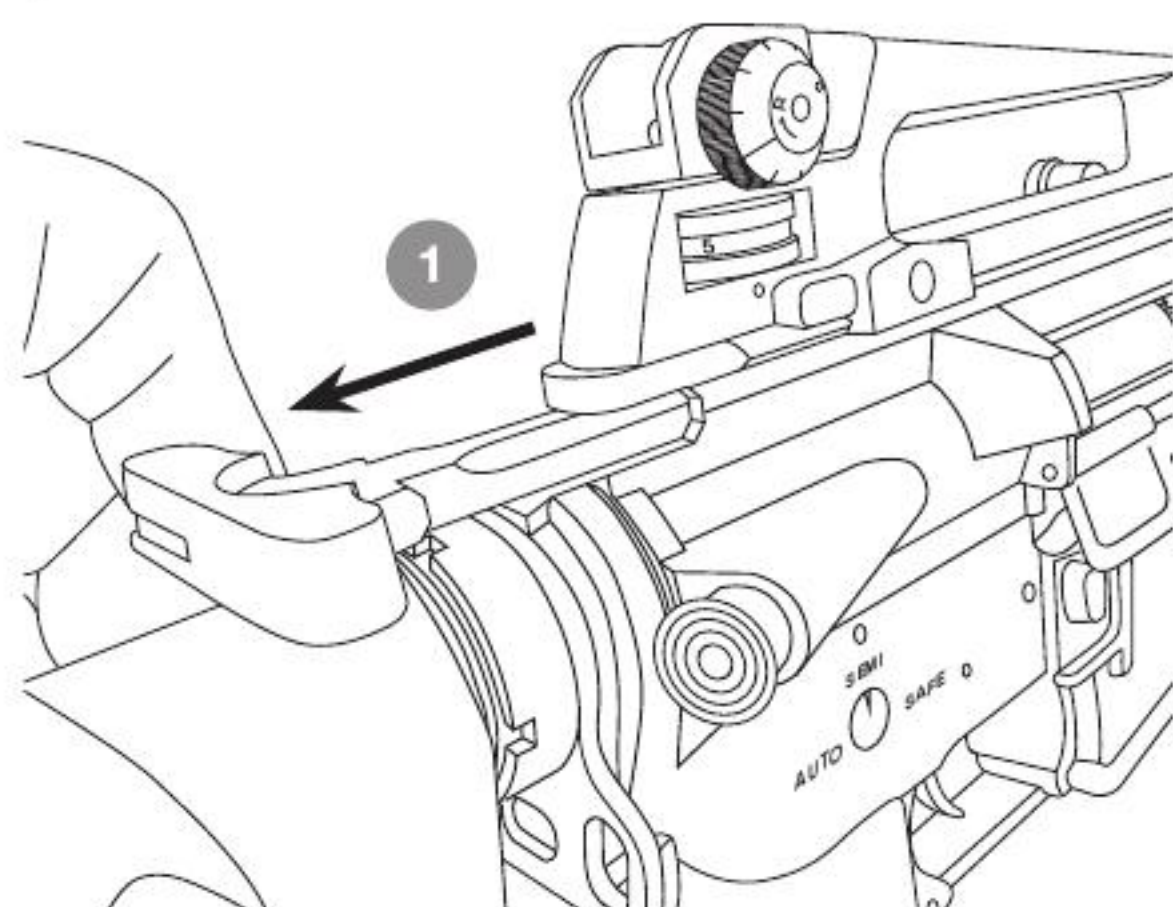



HOP UP ADJUSTMENT

1. Pull back on the charging handle
2. Press the lower portion of the bolt catch lever on the left side of the receiver. The bolt plate will lock back, opening the ejection port and exposing the hop up adjustment dial.
3. Turn the hop up adjustment wheel up to increase hop up. Turn the hop up adjustment wheel down to decrease hop up.
 - Excessively turning the hop up adjustment dial up can cause Airsoft BBs to jam. Continued firing with jammed barrel will cause damage to the gearbox or the hop up.
 - When jamming occurs, immediately stop shooting and turn the hop up adjustment wheel down to withdraw the hop up nub. Remove jammed Airsoft BBs.
4. Once the proper setting for the hop up has been reached, press the upper portion of the bolt catch lever to release the bolt plate.

Before removing jammed airsoft BBs, be sure to return the hop up adjustment wheel to normal position. After removing the BBs, test fire 2-3 rounds to check for clearance. Resume adjustment. KWA Airsoft guns are made with precision barrels, so be sure to use only new, high quality 6mm BBs. The use of recycled or low quality Airsoft BBs are the primary cause of jamming. In most cases, it can severely damage the gearbox, inner barrel, and hop up.



HOP UP ADJUSTMENT POINT

BB TRAJECTORY PATTERN		ADJUSTMENTS
	BB DROPS FREELY	 TURN KNOB UPWARD
	BB TRAVELS AT SHORT TRAJECTORY PATH	 TURN KNOB SLIGHTLY UPWARD
	BB TRAVELS DISTANCE AT FLAT TRAJECTORY PATH	 NO ADJUSTMENTS NECESSARY
	BB TRAVELS FLAT IN SHORT DISTANCE, THEN GOES UP IN CURVE AND DROPS FREELY	 TURN KNOB SLIGHTLY DOWNWARD
	BB TRAVELS AT UNSTABLE SPEED AND IRREGULAR PATH	 TURN KNOB DOWNWARD

AUTO CUT-OFF

The KWA RM4 AEG 3 has a mechanical/electrical auto cut-off feature designed to replicate the actions of a real AR-15, which ceases to fire after the magazine is empty. To reengage the AEG 3, follow the steps below:

1. Place the loaded magazine into the magazine well until it clicks into place.
2. Lightly pull on the magazine to ensure it is locked in properly.
3. Press the bolt catch lever, engaging the gun's firing action

Although the KWA AEG 3 is compatible with many standard AEG magazines, the auto cut-off feature will be disabled with most aftermarket magazines and the rifle will continue to fire regardless of BBs in the magazine.

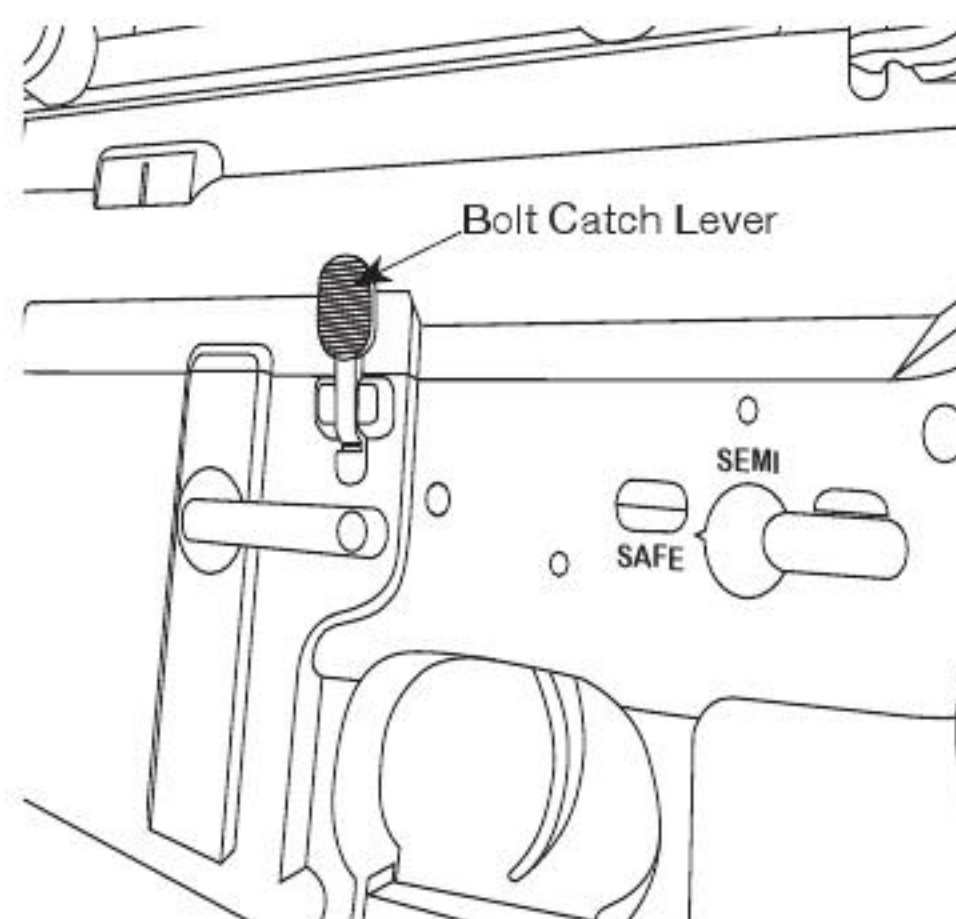

BASIC TROUBLESHOOTING GUIDE FOR RIFLES

SYMPTOMS	POSSIBLE CAUSE	SOLUTIONS
Airsoft gun is not firing	Selector set to Safe Mode	Select Semi-Auto or Full-auto Mode
	Motor damaged or bad connection	Return gun for professional care
	Pinched wiring	Return gun for professional care
	Bad Fuse	Replace fuse
Motor or battery is hot after use	Pinched wiring	Return gun for professional care
	Motor damaged or bad connection	Return gun for professional care
Semi-Auto feature not functioning	Incorrect timing	Dry fire on Full-Auto
High pitch or grinding noise	Gear may be damaged/ Motor level not adjusted	Return gun for professional care
BB double feeding/rolling out of barrel	Hop up unit is contaminated	Clean hop up unit with cleaning rod
	Hop up unit may be damaged	Return gun for professional care
Inner barrel is jammed	Use of low quality/recycled BBs	Use KWA Perfect BBs or other high quality BBs
	Inner barrel is contaminated	Clean inner barrel with cleaning rod
	Inner barrel is damaged	Return gun for professional care

Note: While troubleshooting, only take steps to repair your rifle that fall within warranty specifications. For any questions regarding warranty or troubleshooting, please contact KWA Customer Service at www.kwausa.com

OPERATING UNDER UNUSUAL CONDITIONS

Unusual conditions are defined as any condition requiring special maintenance. Perform maintenance outlined for the climate similar to your operational area.

Extreme Cold:

Operating an Airsoft gun in extremely cold temperatures is not recommended. Cold temperatures will cause the hop-up bucking to harden, reducing its effectiveness. Gas will not expand properly in cold temperatures, so both the cycling rate and power will be dramatically reduced.

Extreme Heat:

Please be mindful of battery, wiring, and motor temperatures in hot weather. Excessive heat can damage electrical components.

Dust or Sand:

Dust or sand can get into a gun and cause malfunctions and/or excessive wear. Keep the gun covered whenever possible. Use lubricant sparingly, as lube naturally attracts dirt and other particles. After use in a dusty area, always field strip the gun (refer to Disassembly Section) and clean any areas you can reach with a soft, lint-free cloth.

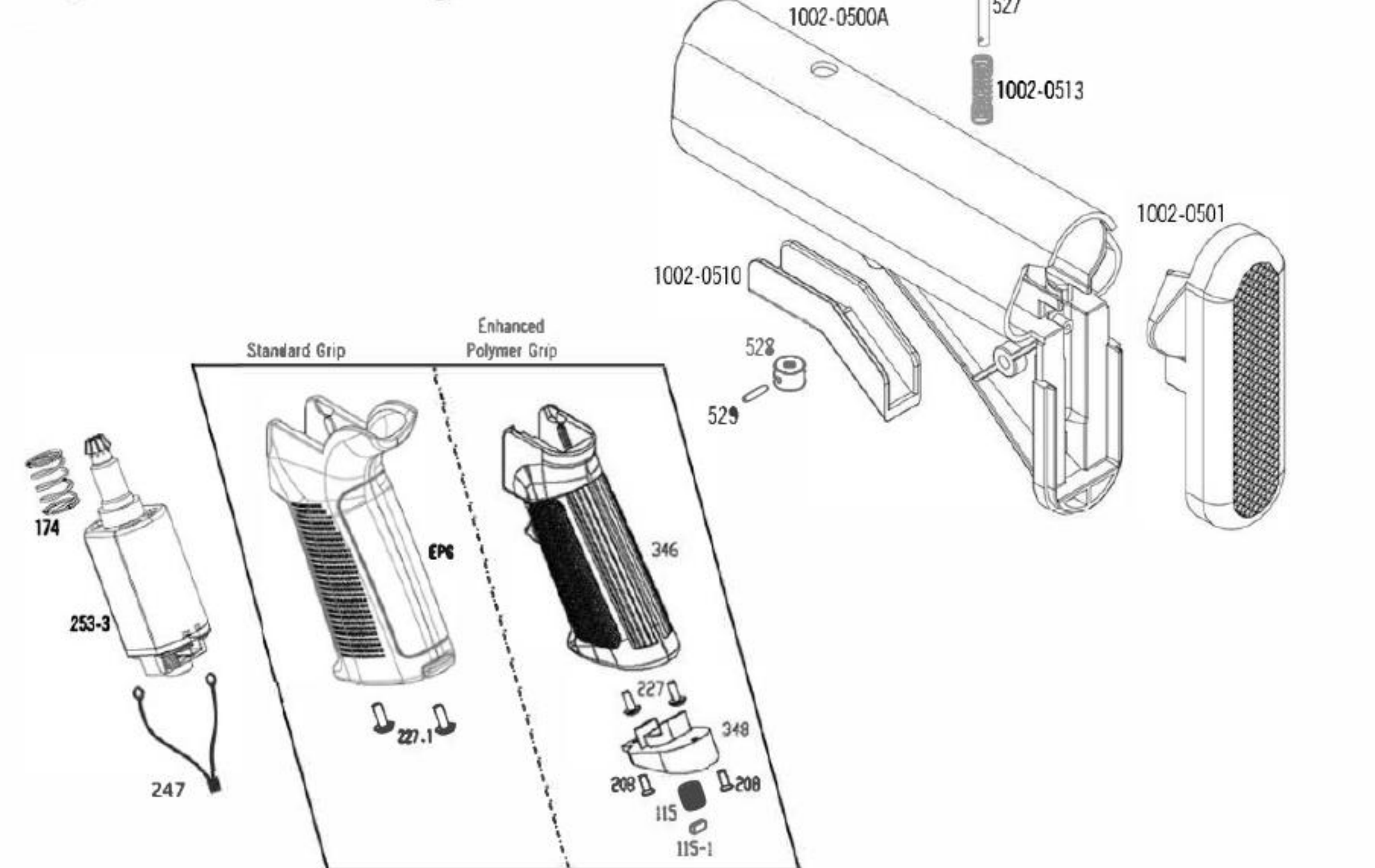
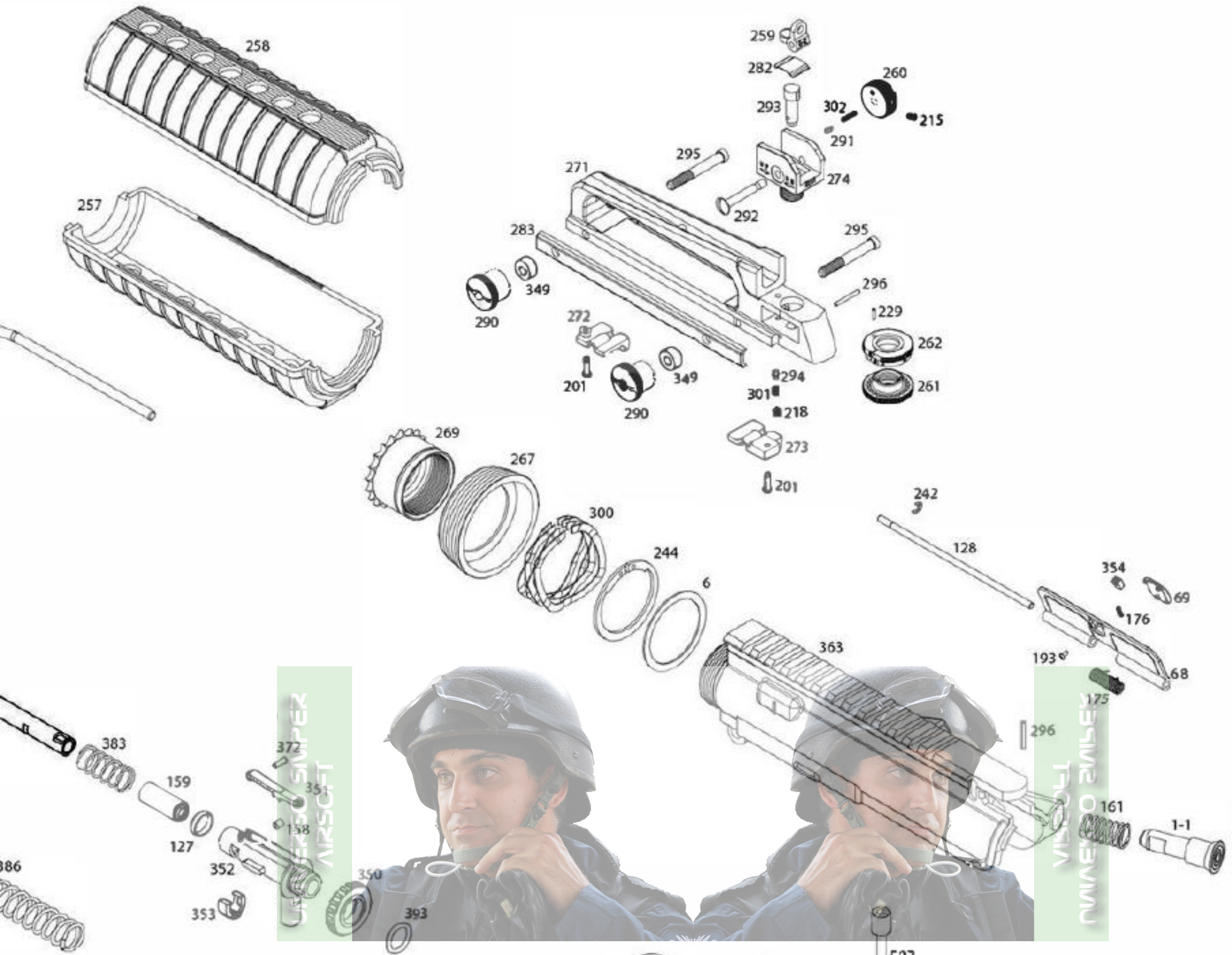

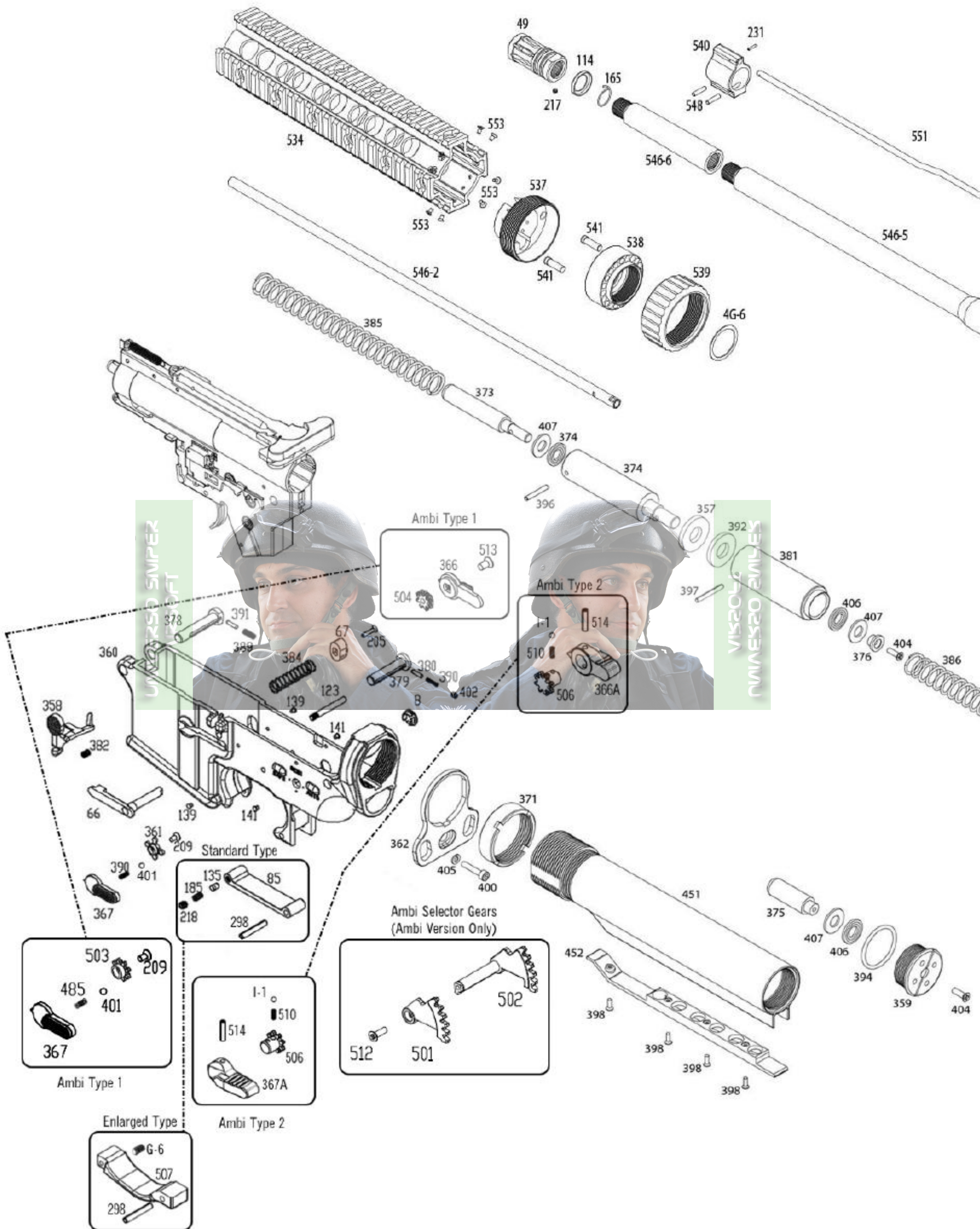

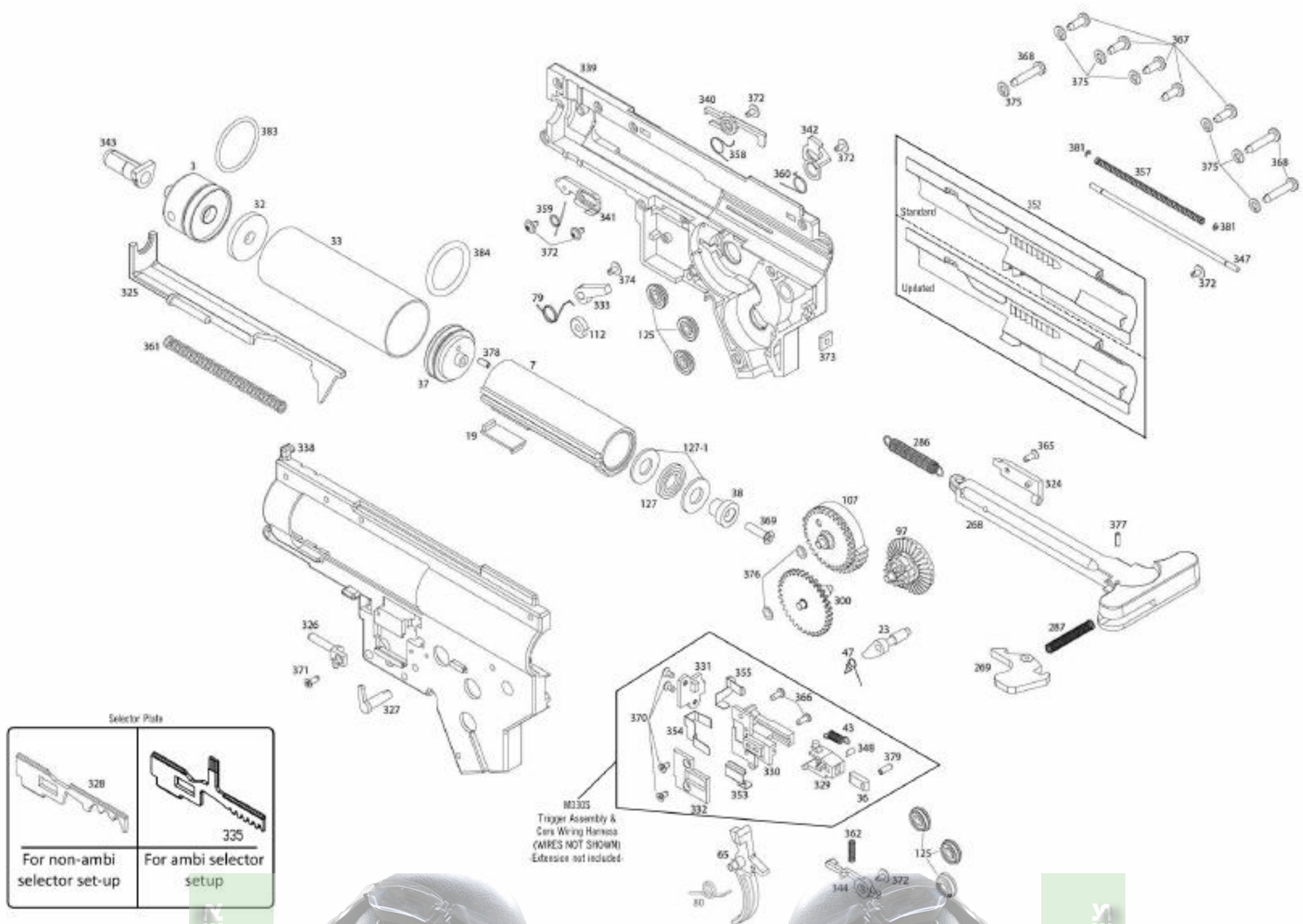

Part #	Description	Part #	Description	Part #	Description
M3	Cylinder Head	M287	Charge Handle Latch Spring	M360	Cut-Off Reset Lever Spring
M7	Piston	M324	Charge Handle Plate	M361	Tappet Plate Spring
M19	Piston Tooth (Steel)	M325	Tappet Plate	M362	Disconnecter Spring
M23	Anti-Reverse Latch	M326	Tappet Plate Spring Guide	M365	Charge Handle Plate Screw
M23-1	Anti-Reverse Latch Axis	M327	Trigger Block Base	M366	Wire Harness Screws x2
M32	Cylinder Head Buffer	M328	Selector Plate	M367	Mech-Box Hex Screws Short x5
M33	Cylinder	M329	Cut-Off Shuttle	M368	Mech-Box Hex Screws Long x3
M36	Cut-Off Brush	M330	Wire Harness Base	M369	Piston Head Screw
M37	Piston Head	M331	Wire Harness Front Plate	M370	Wire Harness Plate Screws x4
M38	Piston Head Retainer	M332	Wire Harness Side Plate	M371	Tappet Plate Spring Guide Screw
M43	Cut-Off Switch Spring	M333	Trigger Block	M372	Retaining Screws x6
M47	Anti-Reverse Latch Spring	M340	Cut-Off Lever	M373	Threaded Insert
M65	Trigger	M341	Shuttle Reset Plate	M374	Trigger Block Screw
M79	Trigger Block Spring	M342	Cut-Off Lever Reset	M375	Lock Washers x7
M80	Trigger Spring	M343	Loading Nozzle	M376	Gear Shims x2
M97	Bevel Gear	M344	Disconnecter	M377	Charge Handle Roll Pin
M101	Spur Gear	M347	Bolt Plate Guide Rod	M378	Piston Head Set Screw
M107	Sector Gear	M348	Shuttle Pin	M379	Cut-Off Brush Roll-Pin
M112	Sector Gear Timing Collar	M352	Bolt Plate	M381	Bolt Plate Spring C-Clamps x2
M125	Bearings x6	M353	Selector Current Brush	M383	Cylinder Head O-Ring
M127	Beveled Washer	M354	Wire Harness Current Brush (Left)	M384	Piston Head O-Ring
M127-1	Piston Head Washers x2	M355	Wire Harness Current Brush (Right)	M386	Gear Box Shell (Left)
M268	Charge Handle	M357	Bolt Plate Spring	M387	Gear Box Shell (Right)
M269	Charge Handle Latch	M358	Cut-Off Lever Spring		
M286	Charge Handle Spring	M359	Shuttle Reset Plate Spring		



KWA Performance Industries, Inc.

T: (626) 581-1777 • F: (626) 581-0777

WWW.STORE.KWAUSA.COM

Copyright © 2017 KWA Performance Industries, Inc.
All Rights Reserved.