

KWA®

LM4 SERIES

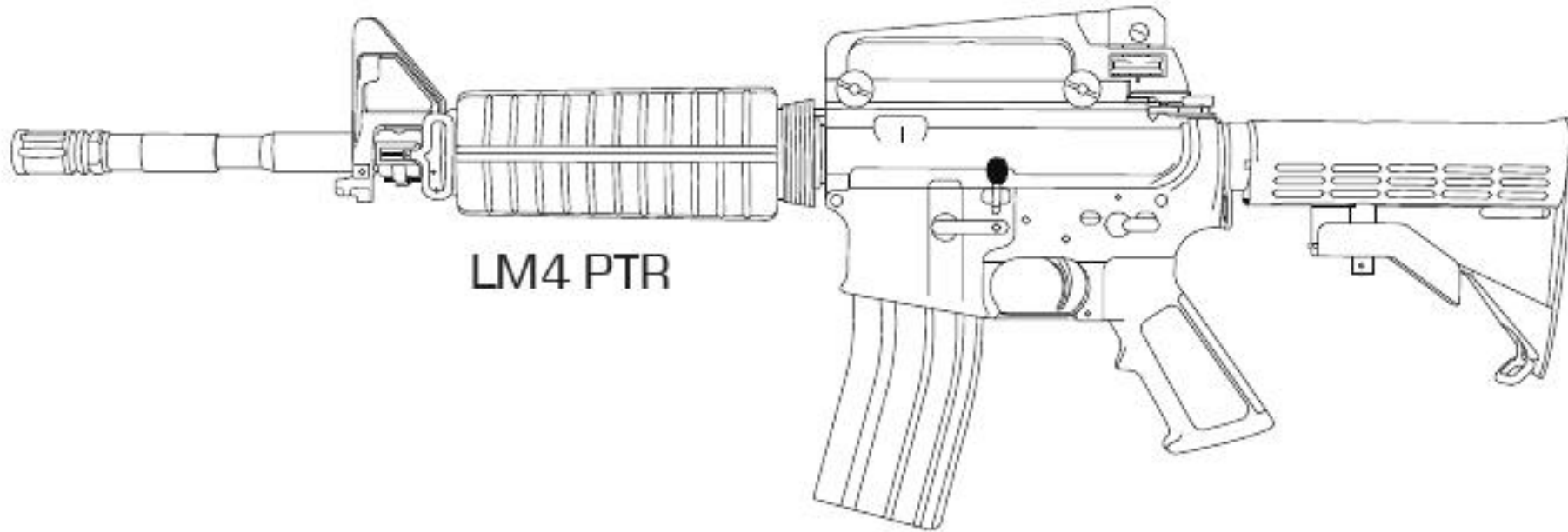

LM4 PTR

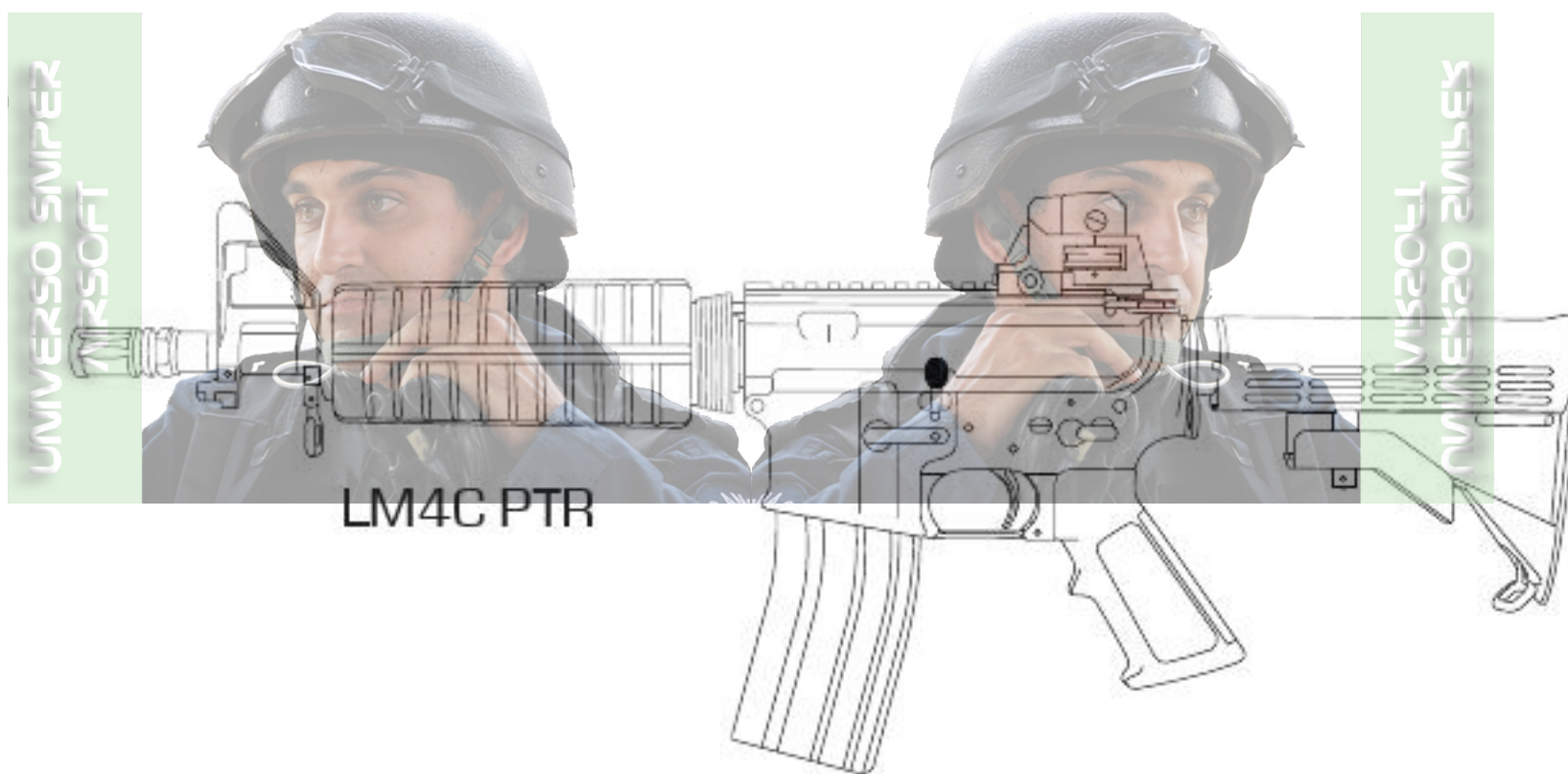

LM4C PTR

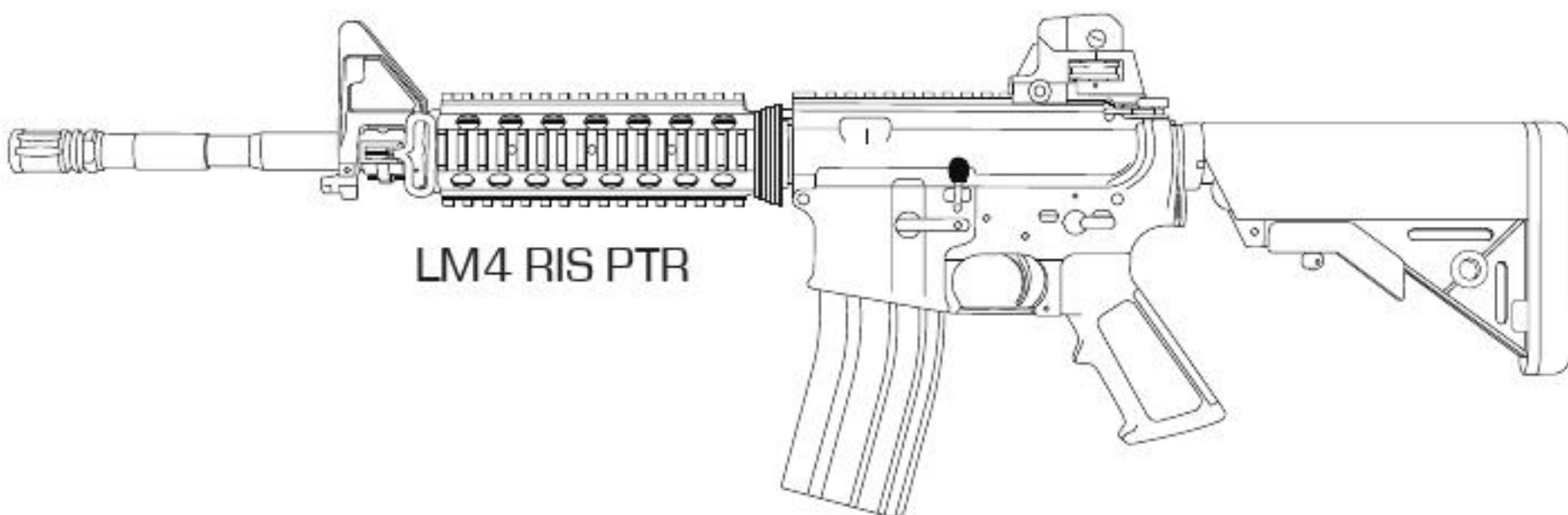

LM4 RIS PTR

OPERATOR'S MANUAL

Please read this manual carefully before using the Airsoft gun.

UNIVERSO SNIPER
AIRSOFT



UNIVERSO SNIPER
AIRSOFT

TABLE OF CONTENTS

Warranty	3-4
Use of this Manual	5
Safety Guidelines	5-6
Specifications and Package Contents:	
LM4 PTR	7
LM4C PTR	8
LM4 RIS PTR	9
Charging Gas	10
Loading BBs	11
Loading Magazine	12
Fire Selector Switch	12
Front and Rear Sight Adjustment	13
Disassembly	14
Assembly	14
Cleaning	15
Hop-Up System	16
Troubleshooting	17
Operating Under Unusual Conditions	17
Diagram and Parts Lists:	
LM4 Series Magazine Parts Diagram	18
LM4 PTR Parts Diagram	19-20
LM4C PTR Parts Diagram	21-22
LM4 RIS PTR Parts Diagram	23-24
Master Parts List	25-26



KWA[®] WARRANTY

KWA PERFORMANCE INDUSTRIES, INC.

18571 E. Gale Ave.

City of Industry, CA 91748

(626) 581-1777

THANK YOU FOR PURCHASING A KWA PERFORMANCE INDUSTRIES, INC. PRODUCT. KWA Performance Industries, Inc. is committed to serving our customers with the finest quality products, the highest level of service, and the best customer satisfaction. Because of this, we offer a 90 day warranty on all KWA products we import and distribute.

Warranty Coverage

Except as specified below, this warranty covers all defects in material and workmanship in KWA products that occur during the above warranty period. The following are not covered by the warranty: (1) Any product which is not imported and distributed in the U.S.A. by KWA PERFORMANCE INDUSTRIES, INC. (2) Any products not purchased in the U.S.A. from a KWA AUTHORIZED RESELLER. If you are uncertain as to whether a reseller is a KWA AUTHORIZED RESELLER, please contact KWA PERFORMANCE INDUSTRIES, INC. as listed above or visit our website www.kwausa.com/where-to-buy (3) Damages, deterioration, or malfunction resulting from: a) An accident, act of nature, abuse, misuse, neglect, opening of or modification or failure to follow instructions supplied with the product. b) Repair or attempted repair by anyone not authorized by KWA PERFORMANCE INDUSTRIES, INC. c) Removal of the orange safety tip. (4) Use of the product outside the U.S.A. (5) Damaged batteries or improper use of bullets (BBs), or non approved propellants (ie. Propane, Red Gas, 134a...etc.) (6) Use in industrial, commercial, and/or professional applications.

What KWA Will Pay For

If your KWA product is found to be defective by KWA Performance Industries, Inc. during the applicable warranty period from the date of original purchase, KWA Performance Industries, Inc. will repair, or at its option, replace with new, used, or equivalent model, the defective product without charge for parts or labor.

How To Obtain Warranty Service

If your product needs service, it may be taken or shipped to KWA Performance Industries, Inc. The following procedures apply whenever your unit must be transported for warranty service:

- You must go to the Help Desk at www.kwausa.com/support to obtain an RMA number. THE RMA NUMBER MUST BE CLEARLY MARKED ON THE OUTSIDE OF THE PACKAGE. PACKAGES WITHOUT AN RMA NUMBER CLEARLY MARKED WILL BE REFUSED AND RETURNED TO THE SENDER.
- You are responsible for transporting your unit or arranging for its transportation.
- If shipment of your unit is required; you must pay the initial shipping fee, but we will pay the return shipping charge if the repairs are covered by the warranty.
- WHEN RETURNING YOUR UNIT FOR WARRANTY SERVICE, A COPY OF THE ORIGINAL SALES RECEIPT MUST BE ATTACHED.
- You must include the following: RMA number, your name, address, daytime telephone number, model and serial number (if applicable) of the product and a description of the problem.

This Warranty is Only Valid in the United States

If your product does not require service, but you have questions regarding its operation, please contact our Help Desk at www.kwausa.com/support.

THIS WARRANTY IS EXPRESSLY MADE IN LIEU OF ALL OTHER WARRANTIES, EXPRESSED OR IMPLIED, INCLUDING WITHOUT LIMITATION, WARRANTIES OF MERCHANTABILITY AND FITNESS FOR A PARTICULAR PURPOSE.

OUR LIABILITY IS LIMITED TO THE REPAIR OR REPLACEMENT, AT OUR OPTION, OF ANY DEFECTIVE PRODUCT AND SHALL IN NO EVENT INCLUDE INCIDENTAL OR CONSEQUENTIAL COMMERCIAL OR PROPERTY DAMAGES OF ANY KIND. WE ARE NOT RESPONSIBLE FOR PRODUCTS LOST, STOLEN AND/OR DAMAGED DURING SHIPPING.

SOME STATES DO NOT ALLOW LIMITATIONS ON HOW LONG AN IMPLIED WARRANTY LASTS AND/OR DO NOT ALLOW THE EXCLUSION OF INCIDENTAL OR CONSEQUENTIAL DAMAGES, THE ABOVE LIMITATIONS AND EXCLUSIONS MAY NOT APPLY TO YOU.

This warranty gives you specific legal rights, but you may also have other rights which vary from state to state. This Warranty may not be altered other than in writing signed by an officer of KWA Performance Industries, Inc.

USE OF THIS MANUAL

Before operating the Airsoft gun, read this manual in its entirety. Important safety topics and tips are discussed throughout all of the chapters. It's important that the operator know the principles of gun handling, safety, and operation prior to firing the Airsoft gun.

SAFETY GUIDELINES

Safety Distance

The effective shooting range is approximately 175 feet. BBs fired from this Airsoft gun may travel further than intended. Make certain that you have an adequate backstop.

Eye Protection

Eye protection should be worn at all times when both shooting and maintaining your Airsoft gun. Protect your eyes from BBs under pressure while performing maintenance on your Airsoft gun.

Assume Every Gun is Always Loaded

Until you are certain the chamber is empty, treat every gun as if it were loaded. Do not assume the chamber is empty based on your memory or someone else's words. Always remove the magazine and visually check to confirm the chamber is empty.

Beware of Barrel Obstructions

Ensure the Airsoft gun barrel is free of obstructions before you fire the gun. Even the smallest obstruction such as dirt, dust, or a stuck cleaning patch can cause a jam, misfire, or malfunction.

Muzzle Control

Always keep the muzzle of the gun pointed in a safe direction. Never point the muzzle at a person or object that you do not intend to shoot.

Keep Your Safety On

Keep the gun's safety on until your sights are aligned on your target and you are ready to fire.

Keep Your Finger Off The Trigger

Keep your finger off the trigger and out of the trigger guard until your sights are aligned on your target and you are ready to fire.

Identify Your Target and Backstop

Before you pull the trigger, make certain of your target and what is beyond it. The Airsoft gun should never be fired at surfaces such as rocks, glass, water, or other hard surfaces where BBs are likely to ricochet in unpredictable directions.



WARNING:

- Airsoft BBs can be a choking hazard. Keep them away from children.
- Failure to follow safety guidelines may result in serious injury.

SAFETY GUIDELINES (CONTINUED)

Failure To Fire

If the Airsoft gun fails to fire, misfires, or malfunctions, do not look into the gun barrel. BBs can become lodged into the chamber, and serious eye injury may occur.

Maintain Your Gun Properly

Performing proper maintenance, as outlined in this manual, ensures that your Airsoft gun will be safe to shoot and will perform to its designed specifications for many years. Alterations, modifications or adjustments may damage your Airsoft gun, make it unsafe to shoot, and will void all warranty claims.

Store Your Gun Safely

Always store the Airsoft gun in a safe place, and out of reach of children. Always transport the Airsoft gun in a carrying case. Never display the Airsoft gun in a public place. Keep the safety engaged, and remove the magazine before storing the Airsoft gun.

NOTE: IT IS YOUR RESPONSIBILITY TO TAKE EVERY REASONABLE PRECAUTION TO ENSURE THE SAFE STORAGE AND TRANSPORTATION OF YOUR AIRSOFT GUN.

Orange Tip

The orange tip on Airsoft guns helps Law Enforcement distinguish between the replica guns from their real firearm counterparts. Altering the coloration or markings required by state or Federal law so as to make the product look more like a firearm is dangerous and may be a crime. Operator assumes all risks and responsibility when doing so.

Hazards of Being Mistaken for a Real Firearm

Airsoft guns have been mistaken by Police and Law Enforcement as real firearms. A confrontation with law enforcement while carrying an Airsoft gun can result in serious injury or even death. It is strongly advised to operate the Airsoft gun at a safe and legal location. In the event that you are approached by Law Enforcement personnel, you must comply with their instructions immediately to avoid an incident.

Alcohol, Medications, and Drugs

Do not handle or operate your Airsoft gun while under the influence of alcohol, medications, or drugs.

Your Responsibility

Your Airsoft gun is well-engineered and manufactured to the highest standards. It was carefully inspected before it was packaged and shipped from our factory. Its safe use depends on you alone. You are the ultimate safety device. Like many other devices, your Airsoft gun is safe unless handled in an irresponsible or uneducated manner.



WARNING:

- Adult supervision is required for any person under the age of 18.

SPECIFICATIONS: LM4 PTR

- Overall Length [Retracted] = 774.7 mm (30.5")
- Overall Length [Extended] = 857.3 mm (33.75")
- Outer Barrel Length = 355.6mm (14")
- Inner Barrel Length = 370 mm (14.57")
- Inner Barrel Diameter = 6.05 mm
- Weight (without magazine) = 2.84 kg (6.28 lbs)
- Barrel thread = -14 mm
- Caliber = 6 mm
- Magazine Capacity = 40 rounds
- Rate of Fire = 13+ RPS
- Velocity = 110~116 MPS (360~380 FPS)*
- Energy Output with 0.20g BB = 1.20 Joules
- Gas System = Force Velocity (FV)
- Propellant = Green Gas

*Individual test results may vary depending on brand of BBs, ambient temperature, and chronograph used.

Special Features:

- Semi and Full Auto Select Fire
- Functional Bolt Catch and Release
- Functional Forward Assist
- Adjustable Front and Rear Sights
- Type 3 Adjustable Hop-Up
- Gas Operated Recoil Blow Back
- One Piece Full Metal Alloy Receivers
- 6 Position Collapsible LE Stock
- Realistic Construction and Field Stripping



PACKAGE CONTENTS: LM4 PTR

- | | |
|-------------------------|--------------------------|
| 1 LM4 PTR Airsoft Gun | 1 Cleaning Rod |
| 1 40 Round Magazine | 1 Hop-Up Adjustment Tool |
| 1 BB Loading Tool | 1 Safety Cap |
| 1 Sight Adjustment Tool | 1 Owners Manual |

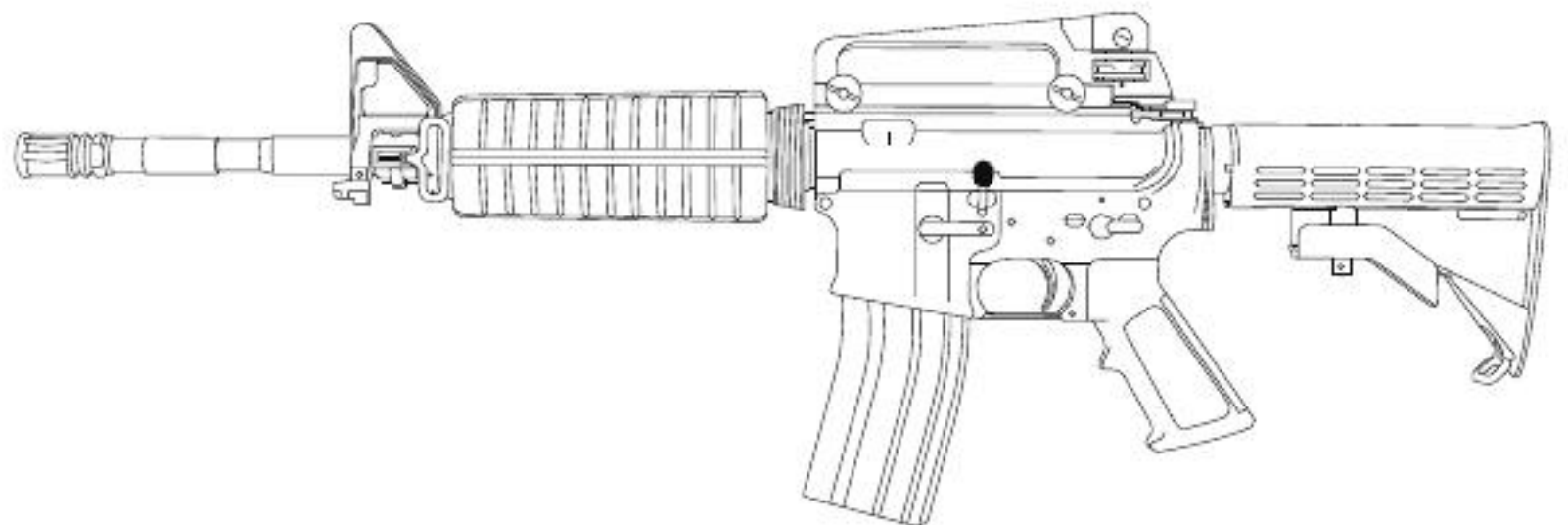

SPECIFICATIONS: LM4C PTR

- Overall Length [Retracted] = 673.1 mm (26.5")
- Overall Length [Extended] = 756.5 mm (29.75")
- Outer Barrel Length = 267mm (10.5")
- Inner Barrel Length = 248 mm (9.76")
- Inner Barrel Diameter = 6.05 mm
- Weight (without magazine) = 2.47 kg (5.45 lbs)
- Barrel thread = -14 mm
- Caliber = 6 mm
- Magazine Capacity = 40 rounds
- Rate of Fire = 13+ RPS
- Velocity = 110~116 MPS (360~380 FPS)*
- Energy Output with 0.20g BB = 1.20 Joules
- Gas System = Force Velocity (FV)
- Propellant = Green Gas

*Individual test results may vary depending on brand of BBs, ambient temperature, and chronograph used.

Special Features:

- Semi and Full Auto Select Fire
- Functional Bolt Catch and Release
- Functional Forward Assist
- Adjustable Front and Rear Sights
- Type 3 Adjustable Hop-Up
- Gas Operated Recoil Blow Back
- One Piece Full Metal Alloy Receivers
- 6 Position Collapsible LE Stock
- Realistic Construction and Field Stripping



PACKAGE CONTENTS: LM4C PTR

- | | |
|-------------------------|--------------------------|
| 1 LM4C PTR Airsoft Gun | 1 Cleaning Rod |
| 1 40 Round Magazine | 1 Hop-Up Adjustment Tool |
| 1 BB Loading Tool | 1 Safety Cap |
| 1 Sight Adjustment Tool | 1 Owners Manual |

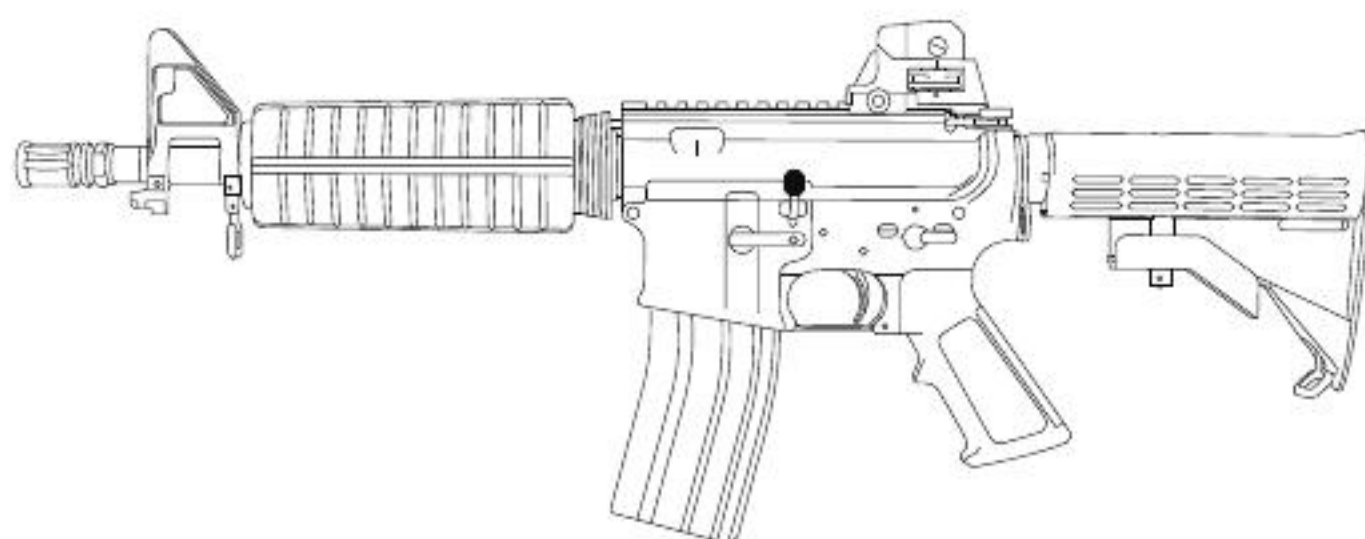

SPECIFICATIONS: LM4 RIS PTR

- Overall Length [Retracted] = 800.1 mm (31.5")
- Overall Length [Extended] = 885.7 mm (34.87")
- Outer Barrel Length = 355.6mm (14")
- Inner Barrel Length = 370 mm (14.57")
- Inner Barrel Diameter = 6.05 mm
- Weight (without magazine) = 2.91 kg (6.42 lbs)
- Barrel thread = -14 mm
- Caliber = 6 mm
- Magazine Capacity = 40 rounds
- Rate of Fire = 13+ RPS
- Velocity = 110~116 MPS (360~380 FPS)*
- Energy Output with 0.20g BB = 1.20 Joules
- Gas System = Force Velocity (FV)
- Propellent = Green Gas

*Individual test results may vary depending on brand of BBs, ambient temperature, and chronograph used.

Special Features:

- Semi and Full Auto Select Fire
- Functional Bolt Catch and Release
- Functional Forward Assist
- Adjustable Front and Rear Sights
- Type 3 Adjustable Hop-Up
- Gas Operated Recoil Blow Back
- One Piece Full Metal Alloy Receivers
- 6 Position Collapsible Crane Stock
- Realistic Construction and Field Stripping
- 2 Piece Rail Interface System



PACKAGE CONTENTS: LM4 RIS PTR

- | | |
|---------------------------|--------------------------|
| 1 LM4 RIS PTR Airsoft Gun | 1 Cleaning Rod |
| 1 40 Round Magazine | 1 Hop-Up Adjustment Tool |
| 1 BB Loading Tool | 1 Safety Cap |
| 1 Sight Adjustment Tool | 1 Owners Manual |

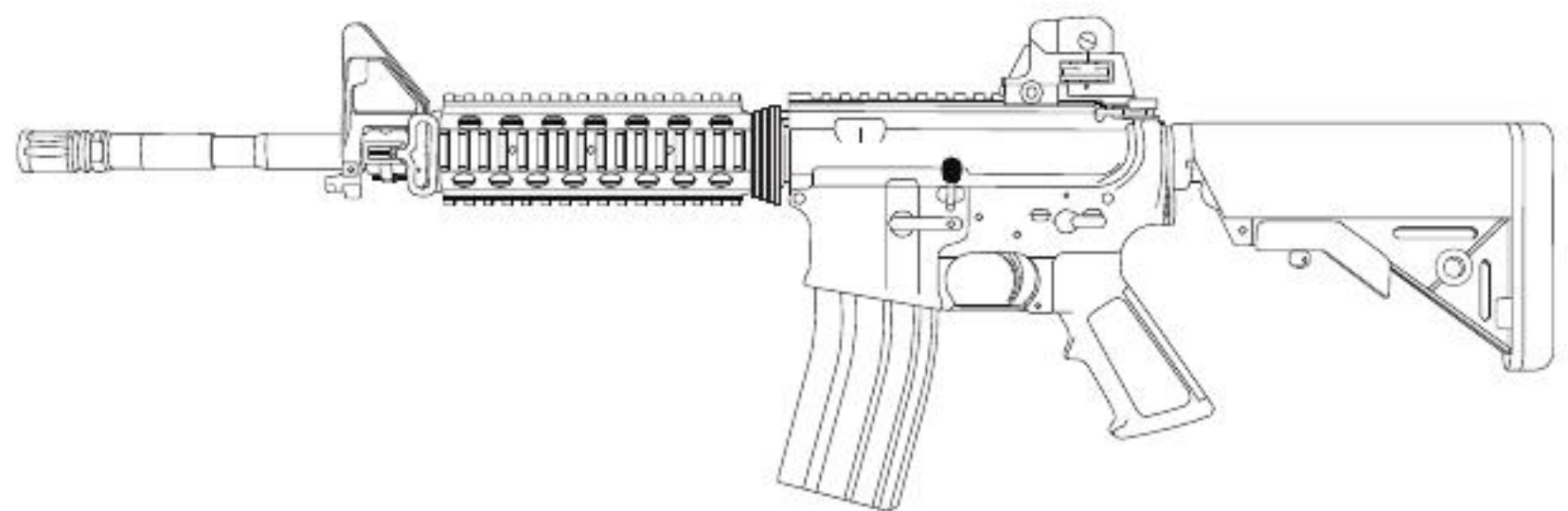

CHARGING GAS

1. Release the magazine by pressing the magazine catch lever towards the magazine.
2. Push the gas canister nozzle into the charging valve. Make sure the canister is in a vertical position when charging.
3. Charge the magazine for approximately 30-40 seconds.

Note: It is normal to have minor leaking from the charging valve during charging due to high pressure built up inside the magazine. It is recommended to keep the gas release valve slightly oiled. Room temperature is the ideal temperature for shooting. You may experience a delayed action if the surrounding temperature drops below 68° F.

Note: Do not expose the magazine to direct sunlight or incinerate the magazine, as this may cause the magazine to burst. It is strongly recommended to empty the gas from the magazine after shooting. Be certain that the gas does not make contact with eyes or skin while being released, as any contact will cause cold burns.

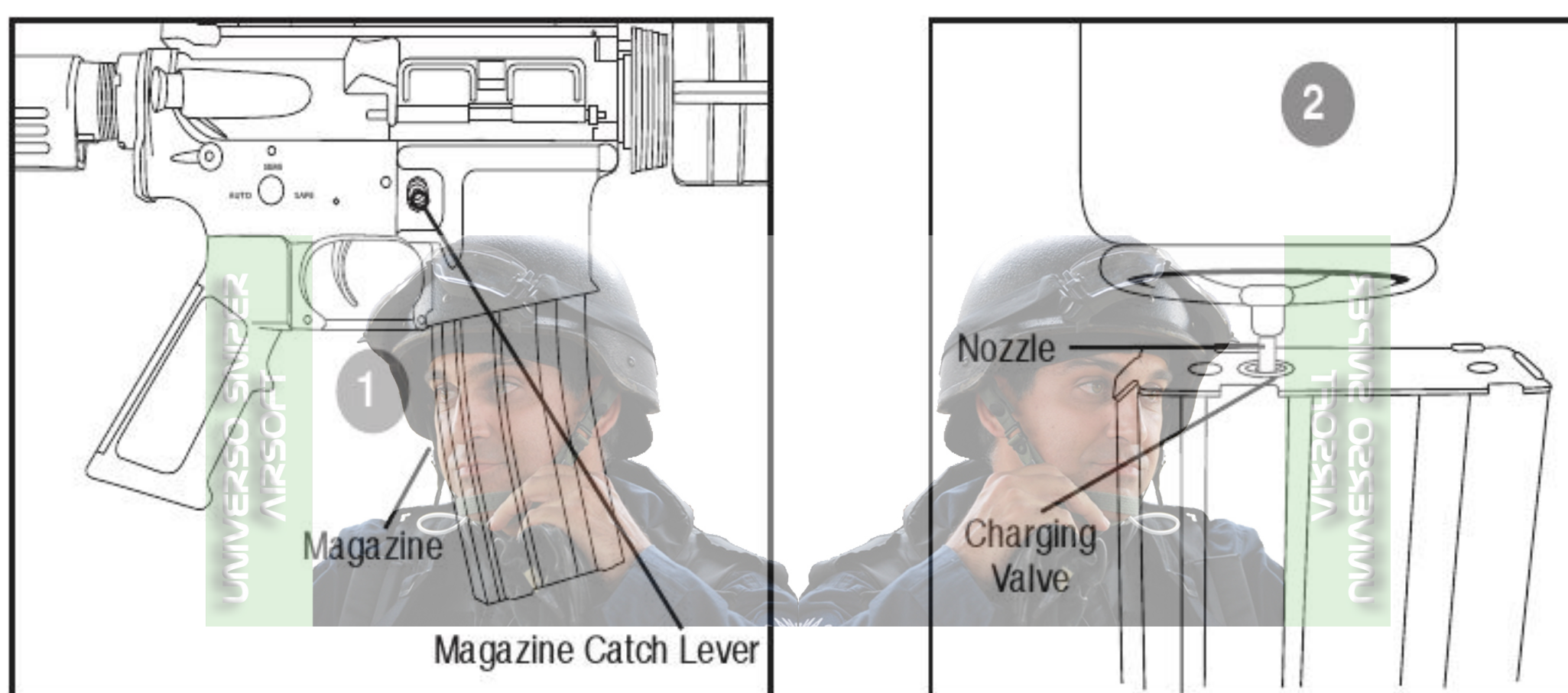

Green Gas safety tips:

- Check the canister for any cracks or leaks before using.
- Do not expose the canister to temperature over 104° F.
- Do not leave the canister directly over fire.
- Do not heat the canister.
- Keep the canister away from direct sunlight.
- Do not leave the canister in any type of vehicle.



WARNING:

- **Avoid dropping the magazine. Sudden impact with a hard surface may cause damage to the magazine.**

LOADING BBS

1. Release the magazine from the Airsoft gun by pressing the magazine catch lever.
2. Fit the standard BB loader over the magazine feed lip.
3. Load the BBs into the BB loader.
4. Insert the plunger into the BB loader and push down to load BBs into the magazine.
5. Leave a 3mm clearance between the BBs and the top of the magazine lip.
Overloading will cause jamming.

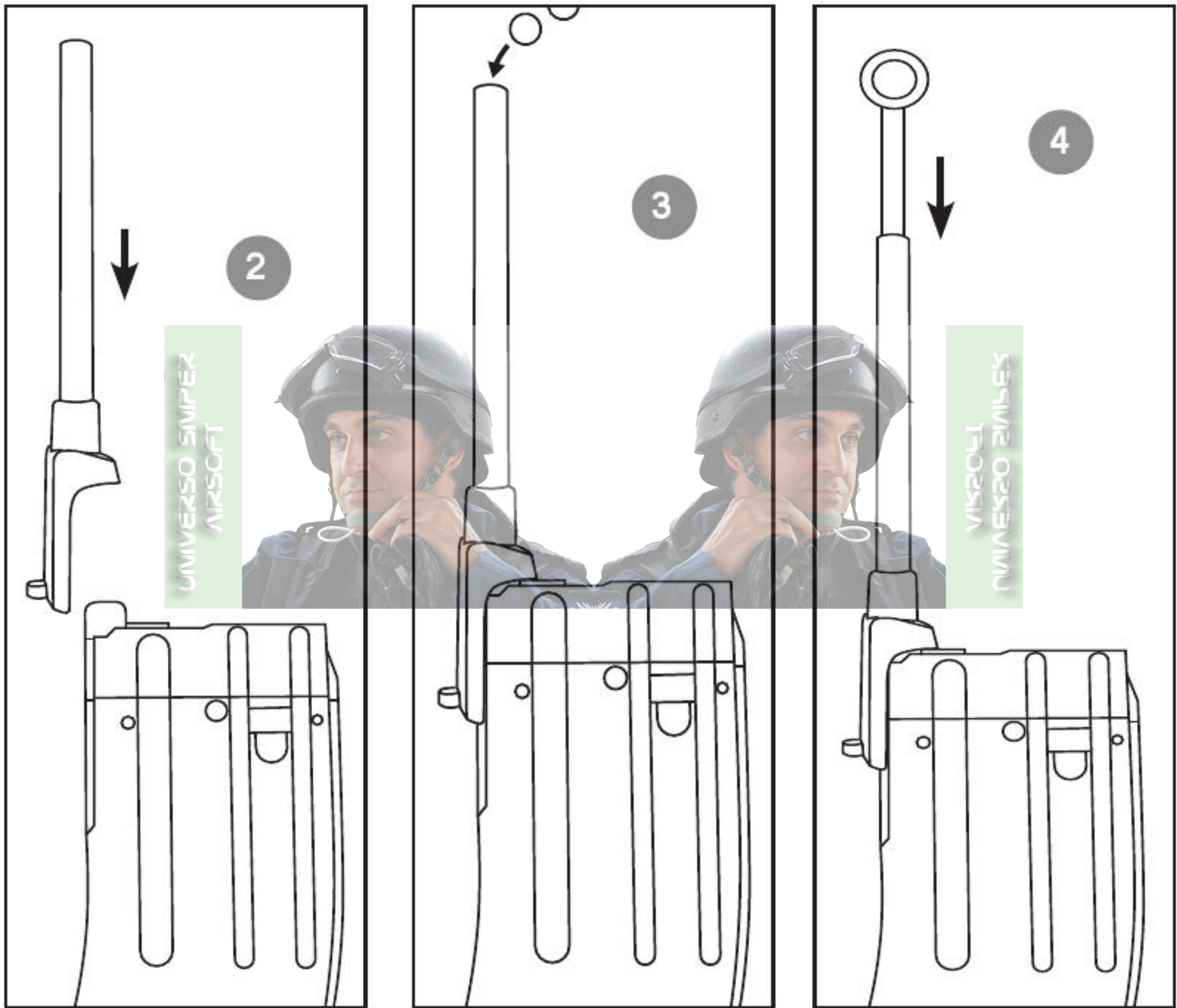

WARNING:

- Always use high quality 6mm BBs, weighing 0.2g or heavier. For best results use 0.25g KWA Perfect BBs. Never use recycled or low grade BBs to prevent damage to your gun.

LOADING MAGAZINE

1. Place the loaded magazine into the magazine well.
2. Lightly pull on the magazine to ensure it is locked in properly.
3. Pull the charging handle back to chamber the first round.
4. If the bolt is locked back, it can be released by pressing the bolt catch button.

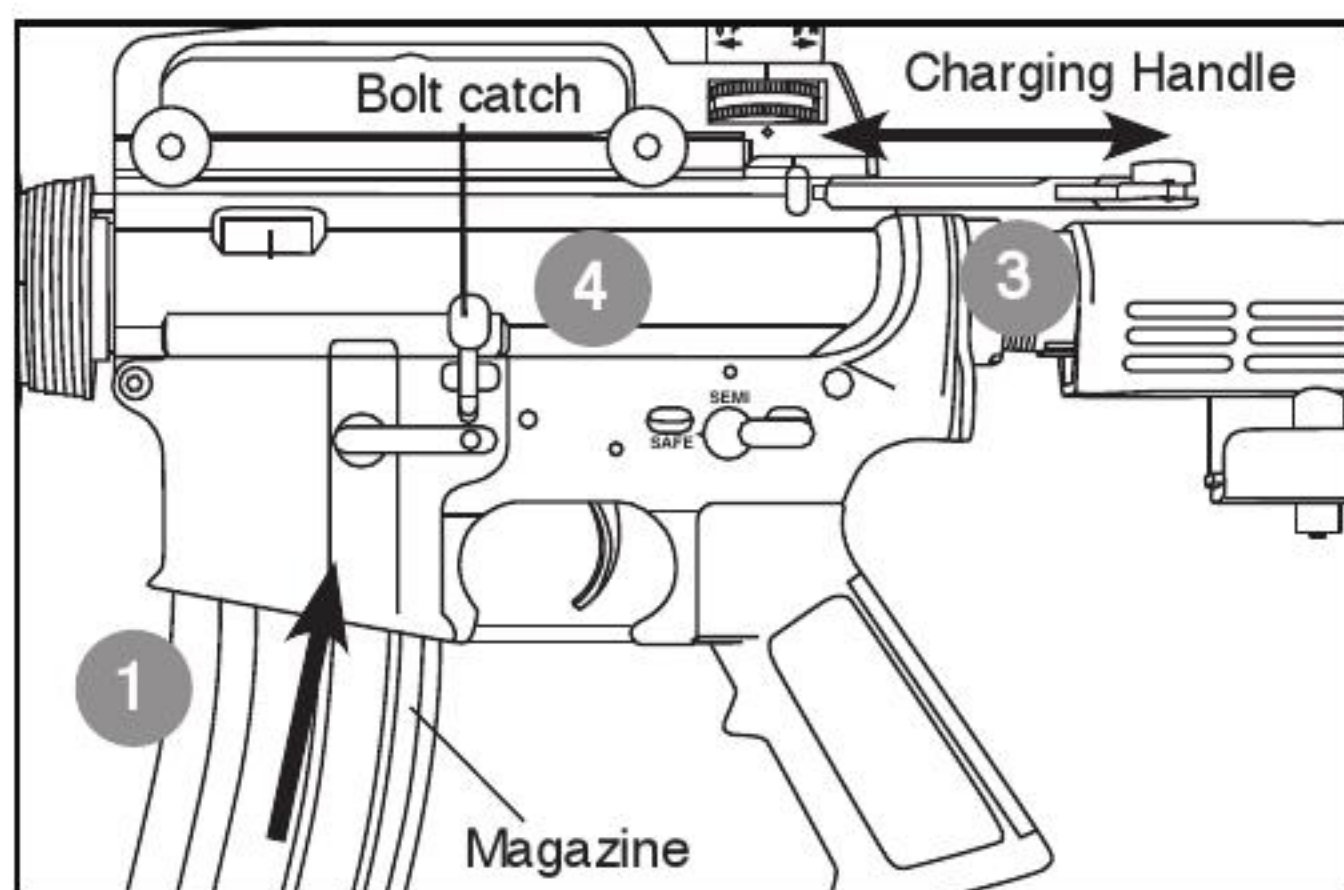

FIRE SELECTOR SWITCH

1. Safe

Safe mode is the setting to the left as indicated in the diagram. In this mode the gun will not fire. For safety reasons, you should keep the switch in Safe mode at all times when you are not ready to fire.

2. Semi-Auto

Semi-Auto mode is the middle setting. In this mode the gun will fire one shot for each time you squeeze the trigger.

3. Full Auto

Full Auto mode is the setting to the right. In this mode the gun will fire continuously as long as the trigger is engaged.

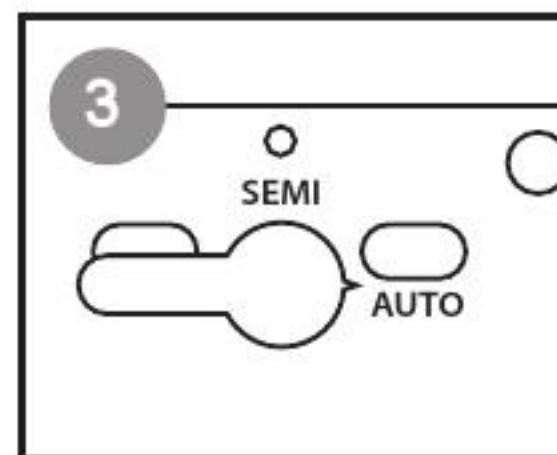
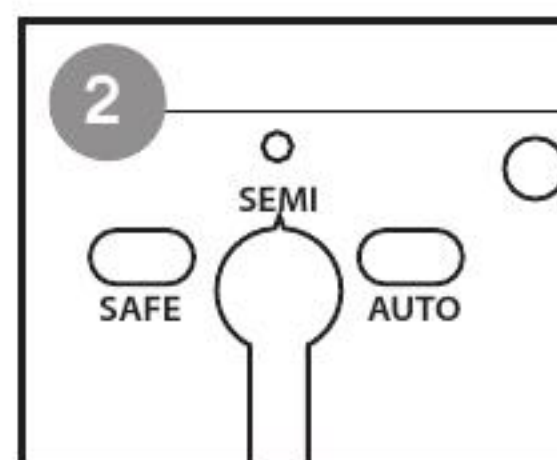
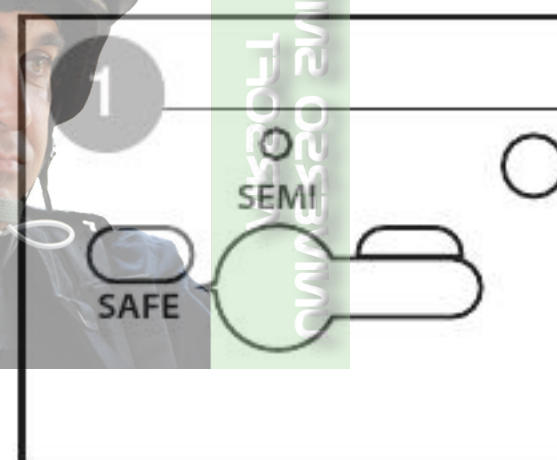

WARNING:

- Do not squeeze the trigger when switching the fire selector.
- Selector switch will not turn to safe if hammer is not cocked.

FRONT AND REAR SIGHT ADJUSTMENT

FRONT SIGHT ADJUSTMENT

1. The front sight can be moved up and down to zero the sights.
2. Turn counter clockwise to raise the post.
3. Turn clockwise to lower the post.

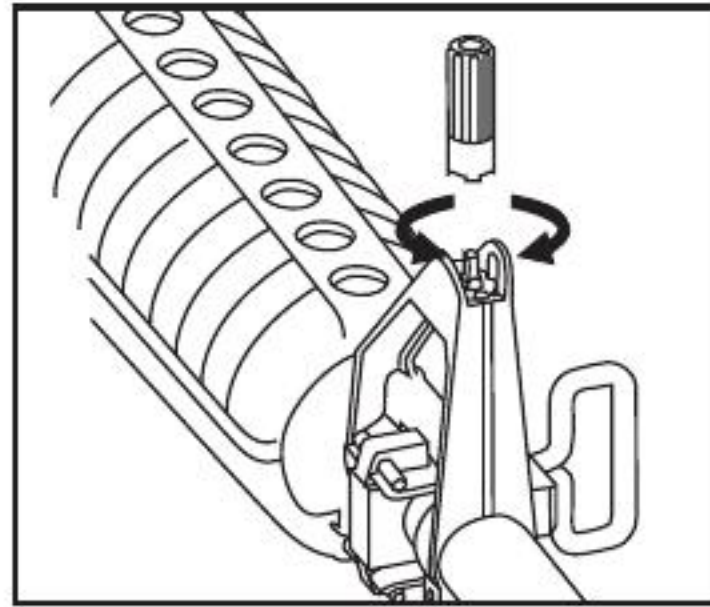

REAR SIGHT ADJUSTMENT

1. Flip the rear sight between general and precision aiming.
2. To adjust the horizontal point of impact, rotate the windage knob located on the rear of the sight.
3. To adjust the vertical point of impact, rotate the sight elevation knob located on the left and right side of the sight.

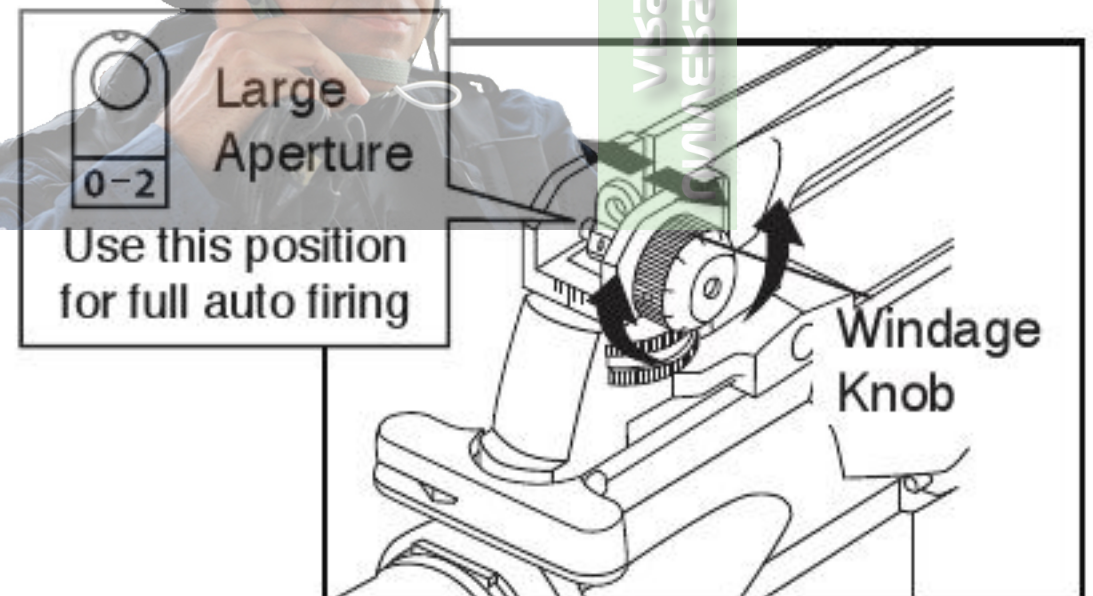
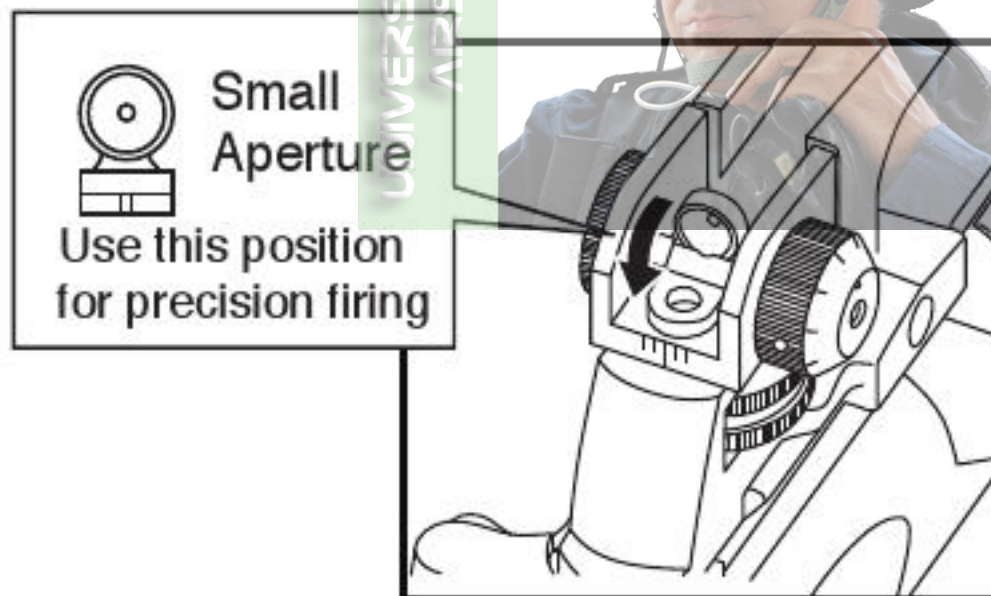

The sight assembly is marked in millimeter for precise adjustments

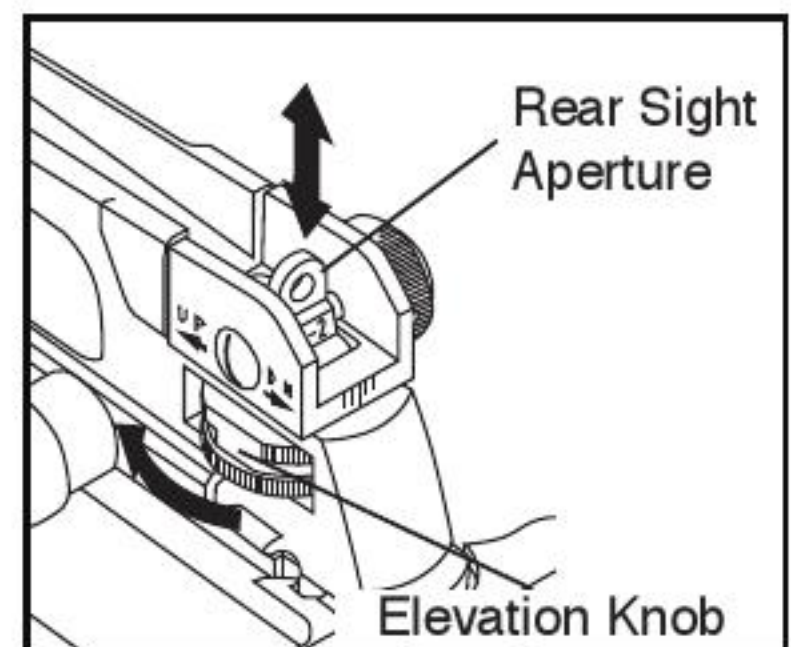
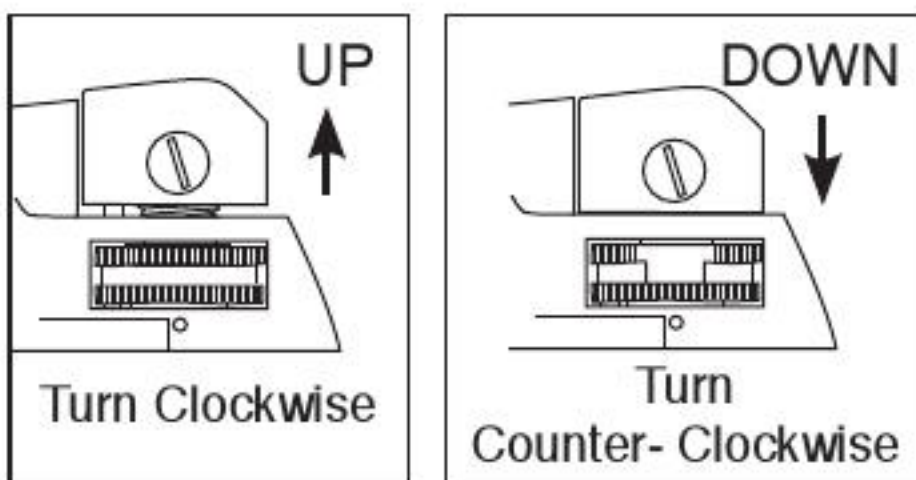

WARNING:

-If turned too far, the front sight will come off.

DISASSEMBLY

1. Remove magazine.
2. Charge the bolt to reset the hammer.
Note: Check and clear the chamber of BB's.
3. Set the selector to **SAFE**.
4. Push in the receiver pins.
5. Lift the upper receiver from the lower receiver.
6. Pull out the charging handle to remove the bolt carrier.

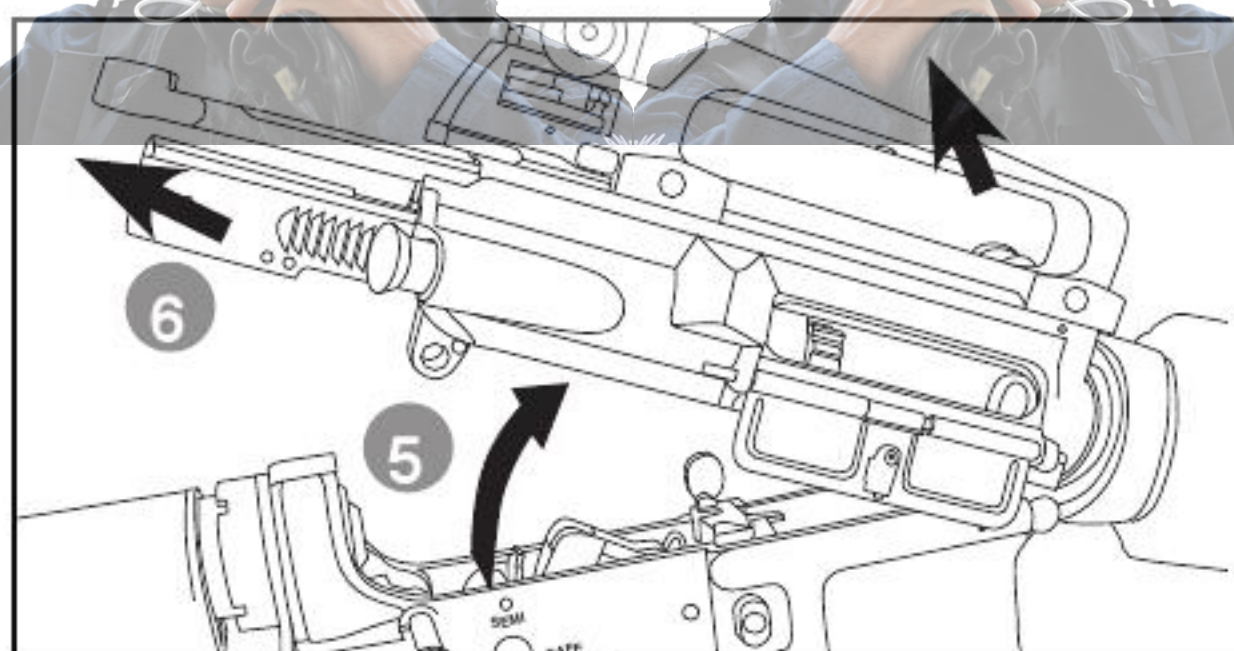
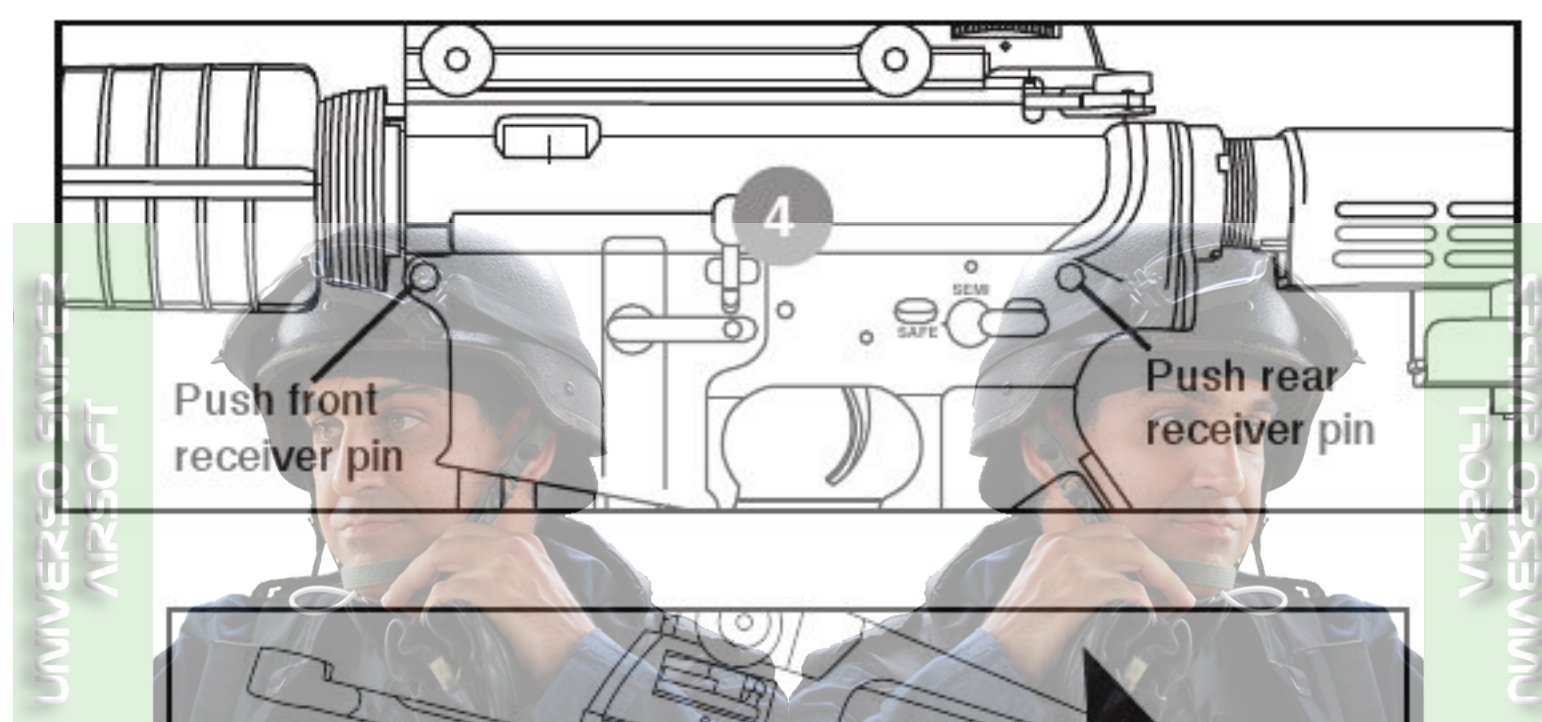
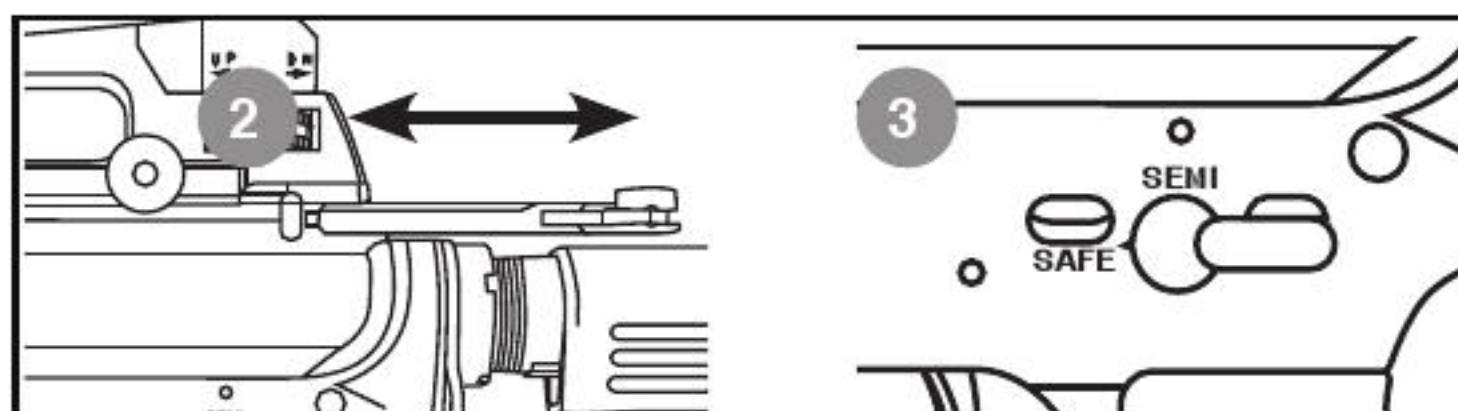

ASSEMBLY

1. Re-install the charging handle and bolt carrier to the upper receiver.
2. Re-attach the upper receiver to the lower receiver.
3. Push the receiver pins into place.
4. Cycle bolt to ensure proper re-assembly.



WARNING:

- Always place the safety cap on the barrel tip when servicing your gun.

CLEANING

The Airsoft gun inner barrel should be cleaned after each shooting session. Regular cleaning prevents the effects of BB residue buildup that can hinder performance.

1. Ensure that the safety is engaged.
2. Remove the magazine and clear the chamber of loaded BBs.
3. Disassemble the receiver (see Disassembly section pg. 12).
4. Steps to use cleaning rod:
 - a. Cut a piece of clean cotton cloth to 1 inch by 0.5 inch size. Insert one end of the cloth into the hole in the cleaning rod (adjust the length of cloth for smooth entry into the barrel).
 - b. Wind the cloth around the cleaning rod.
 - c. Insert the cleaning rod into the inner barrel, and push the rod through.
 - d. Remove the cleaning rod and check the cotton cloth for dirt. Repeat steps a. through c. when necessary.
5. Oil the piston seal and hammer.

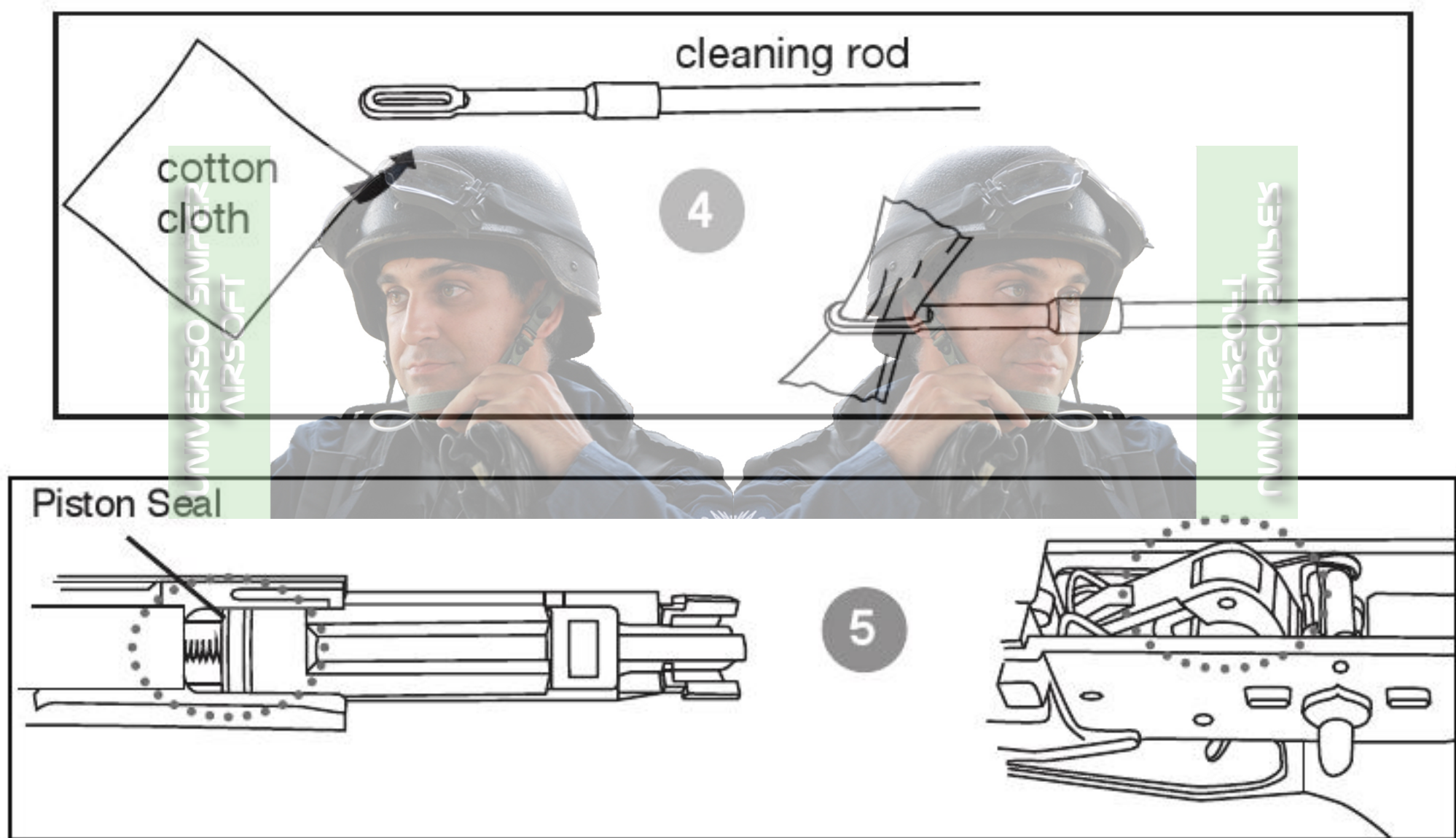

NOTE: Lubricating dry seals and o-rings are essential. Unload BBs from the magazine. Make sure the magazine is free of gas before lubricating the magazine's charging valve and release valve.

Use only the recommended 100% silicone oil, available for purchase at the Airsoft dealer where you purchased your KWA products. Any other type of lubricant may damage the products.



WARNING:

- Unload and clear the Airsoft gun before cleaning.
- DO NOT use spray silicone oil as a cleaning solution for the inner barrel.

HOP-UP SYSTEM

The Hop-Up device is one of KWA's standard features, giving Airsoft BBs greater stability, further travel, and increased accuracy. Airsoft BBs are lightweight and can be affected by wind when fired. With the Hop-Up system, the trajectory of the Airsoft BBs can be adjusted according to the shooting environment or surroundings.

HOP-UP ADJUSTMENT

1. Test fire the gun to determine the amount of hop needed.
2. Remove the magazine.
3. Pull the charging handle back to clear chamber and open the ejection port cover.
4. Insert the Hop-Up adjustment tool and turn the Hop-Up Dial to adjust hop.
5. Left for more hop, right for less hop.
6. Test fire and adjust as needed.

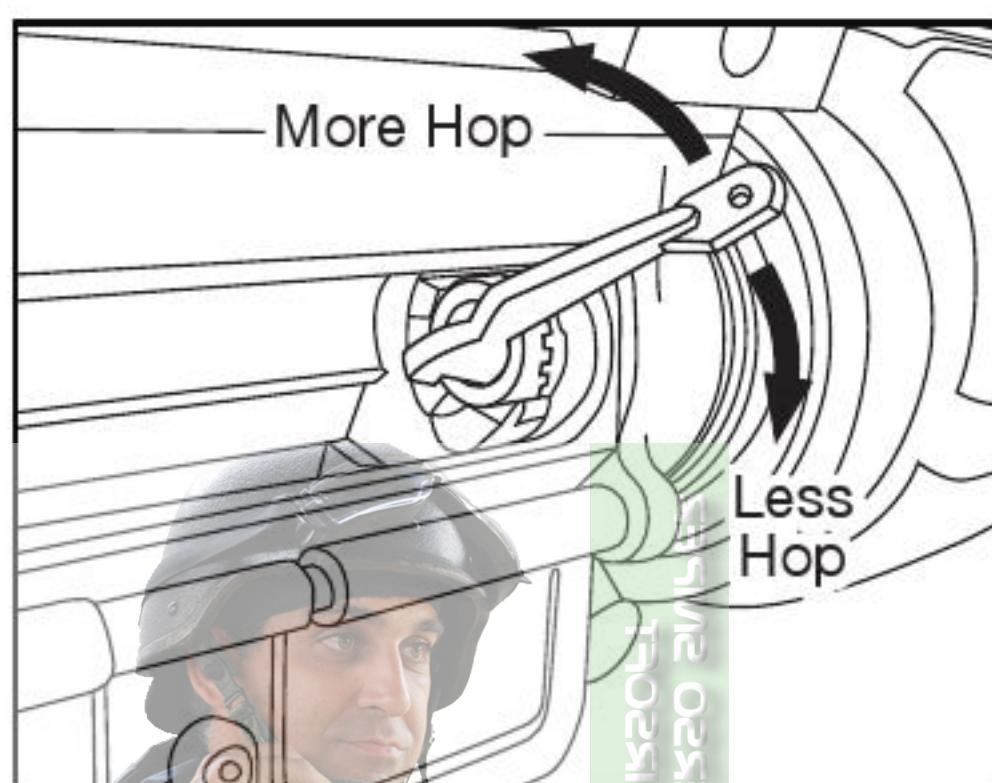
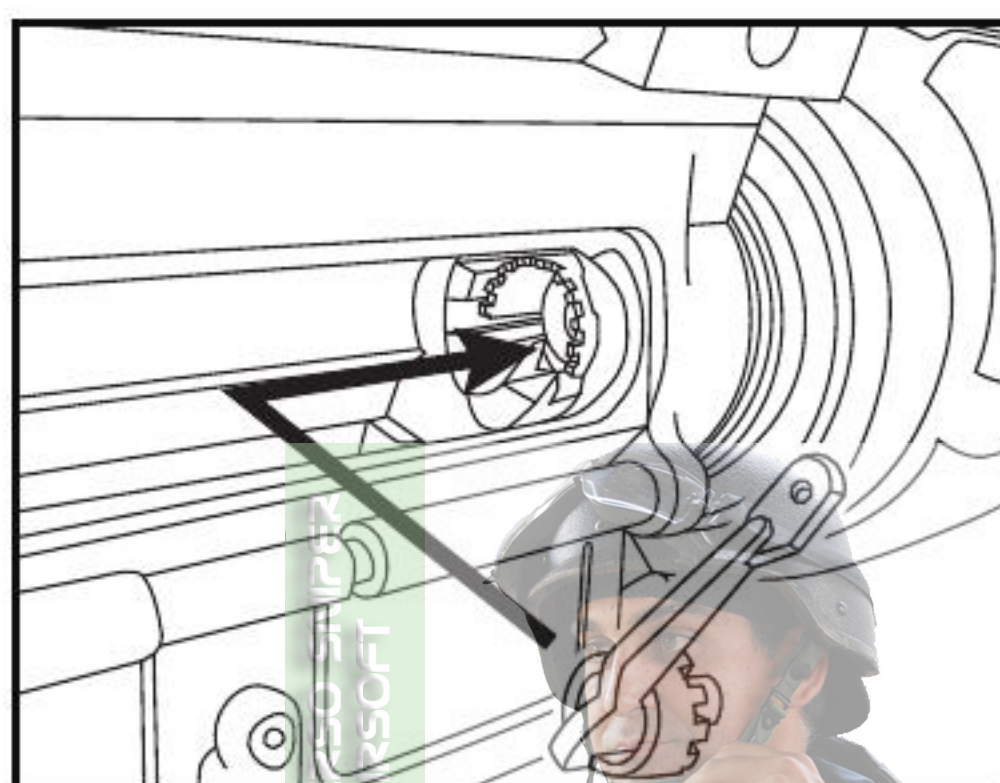

HOP-UP ADJUSTMENT POINT

BB TRAJECTORY PATTERN		ADJUSTMENTS
	BB DROPS FREELY	TURN KNOB TO LEFT
	BB TRAVELS AT SHORT TRAJECTORY PATH	TURN KNOB SLIGHTLY TO LEFT
	BB TRAVELS DISTANCE AT FLAT TRAJECTORY PATH	NO ADJUSTMENT MADE
	BB TRAVELS FLAT IN SHORT DISTANCE, THEN GOES UP IN CURVE AND DROPS FREELY	TURN KNOB SLIGHTLY TO RIGHT
	BB TRAVELS AT UNSTABLE SPEED AND IRREGULAR PATH	TURN KNOB TO RIGHT

WARNING:

- Do not release the bolt with hand in the chamber.

BASIC TROUBLESHOOTING GUIDE FOR RIFLES		
SYMPTOMS	POSSIBLE CAUSE	SOLUTIONS
Bolt jams / Will not complete cycle	Dry internals	Add silicone to cylinder / main seal
Double feeds BBs into chamber / BB's roll out of barrel	Hop-up adjustment too tight	Release hop-up or replace bucking
BBs will not release from magazine / bent mag lip/ check BB condition	Bent magazine lip	Replace magazine lip
Leaking release valve & charging valve	Dry O-ring	Add silicone oil to valves / Replace valves
Magazine base plate will not lock	Broken base plate lock	Replace base plate lock
Magazine base leaking air	Worn out base seal	Replace magazine base seal
Cylinder will not load BBs into chamber	Broken cylinder tab	Replace cylinder
Trigger will not reset	Worn out trigger spring / trigger bow spring	Replace trigger spring / trigger bow spring

OPERATING UNDER UNUSUAL CONDITIONS

Unusual conditions are defined as any condition requiring special maintenance. Perform maintenance outlined for the climate similar to your operational area.

Extreme Cold:

Operating an Airsoft gas gun in extremely cold temperatures is not recommended. Cold temperatures will cause the Hop-up Bucking to harden, reducing its effectiveness. Gas will not expand properly in cold temperatures, so both the cycling rate and power will be dramatically reduced.

Extreme Heat:

Operating an Airsoft gas gun in extremely hot temperatures is also not recommended. Leaving the gun in direct sunlight for long periods of time, or operating in extremely hot areas will cause the gas to over-expand, damaging the internal workings of the gun. The increase in internal pressure from the expanding gas can also damage the seals and cause leaks in the magazine.

Dust or Sand:

Dust or sand can get into a gas gun and cause malfunctions and/or excessive wear. Keep the gun covered whenever possible. Use lubricant sparingly, as lube naturally attracts dirt and other particles. After use in a dusty area, always field strip the gun (refer to Disassembly Section) and clean any areas you can reach with a soft, lint-free cloth.

LM4 PTR MAGAZINE PARTS DIAGRAM

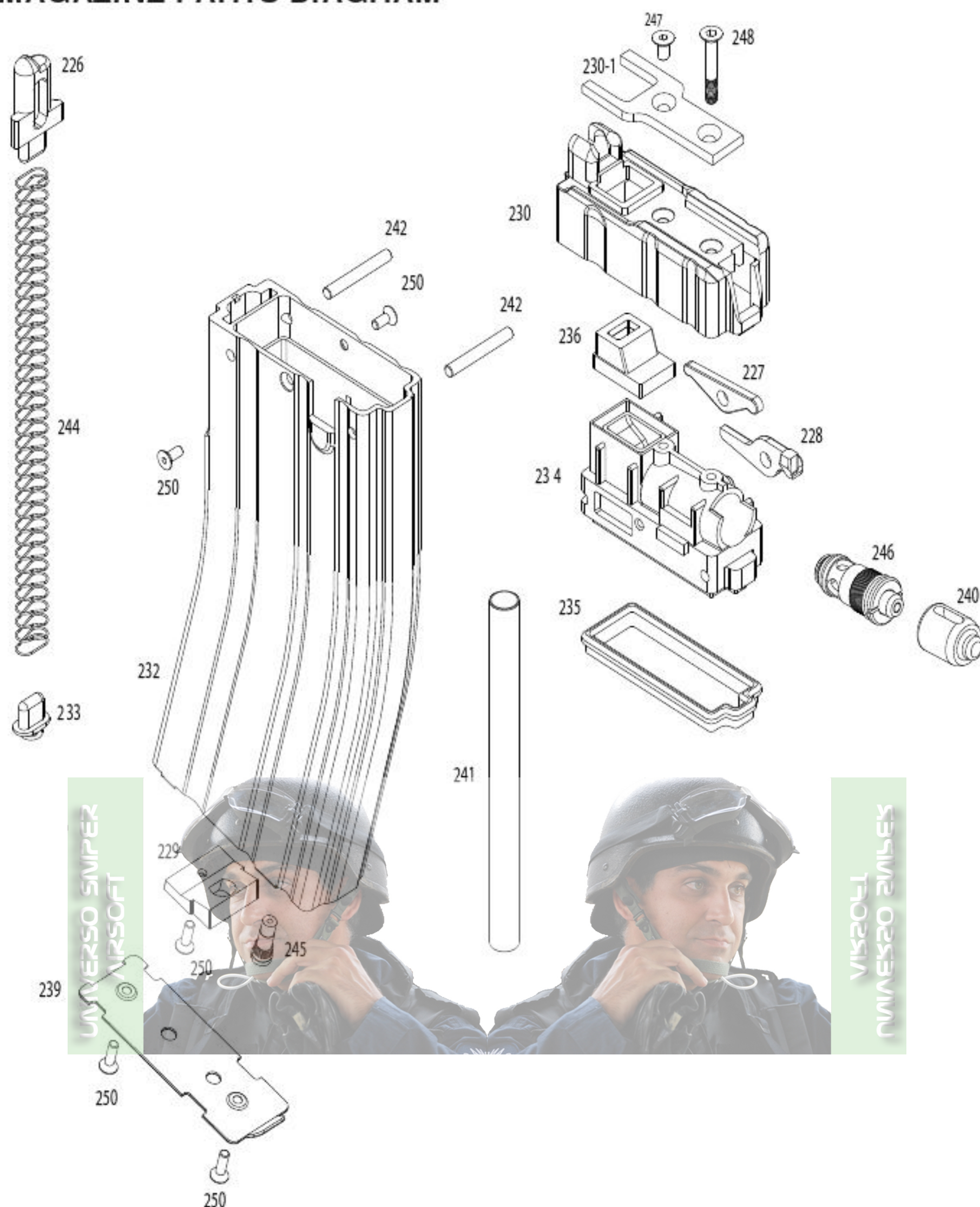

LM4 PTR MAGAZINE PARTS LIST

Part#	Description
MG226	MAGAZINE FOLLOWER
MG227	MAGAZINE DISCONNECT TRANSFER
MG228	MAGAZINE DISCONNECTOR
MG229	MAGAZINE SPRING STOP BASE
MG230	MAGAZINE FEED LIP
MG230-1	MAGAZINE LIP RETAINING PLATE
MG232	MAGAZINE BODY
MG233	MAGAZINE SPRING STOP
MG234	MAGAZINE RELEASE VALVE BLOCK
MG235	MAGAZINE RELEASE VALVE BLOCK SEAL
MG236	MAGAZINE NOZZLE SEAL

Part#	Description
MG239	MAGAZINE BASE PLATE
MG240	MAGAZINE RELEASE VALVE CAP
MG241	MAGAZINE GAS EXPANSION TUBE
MG242	MAGAZINE RELEASE VALVE BLOCK PIN
MG244	MAGAZINE FOLLOWER SPRING
MG245	MAGAZINE CHARGING VALVE
MG246	MAGAZINE RELEASE VALVE
MG247	MAGAZINE FEED LIP SCREW (SHORT)
MG248	MAGAZINE FEED LIP SCREW (LONG)
MG250	MAGAZINE BASE SCREWS

LM4 SERIES

LM4 PTR PARTS DIAGRAM

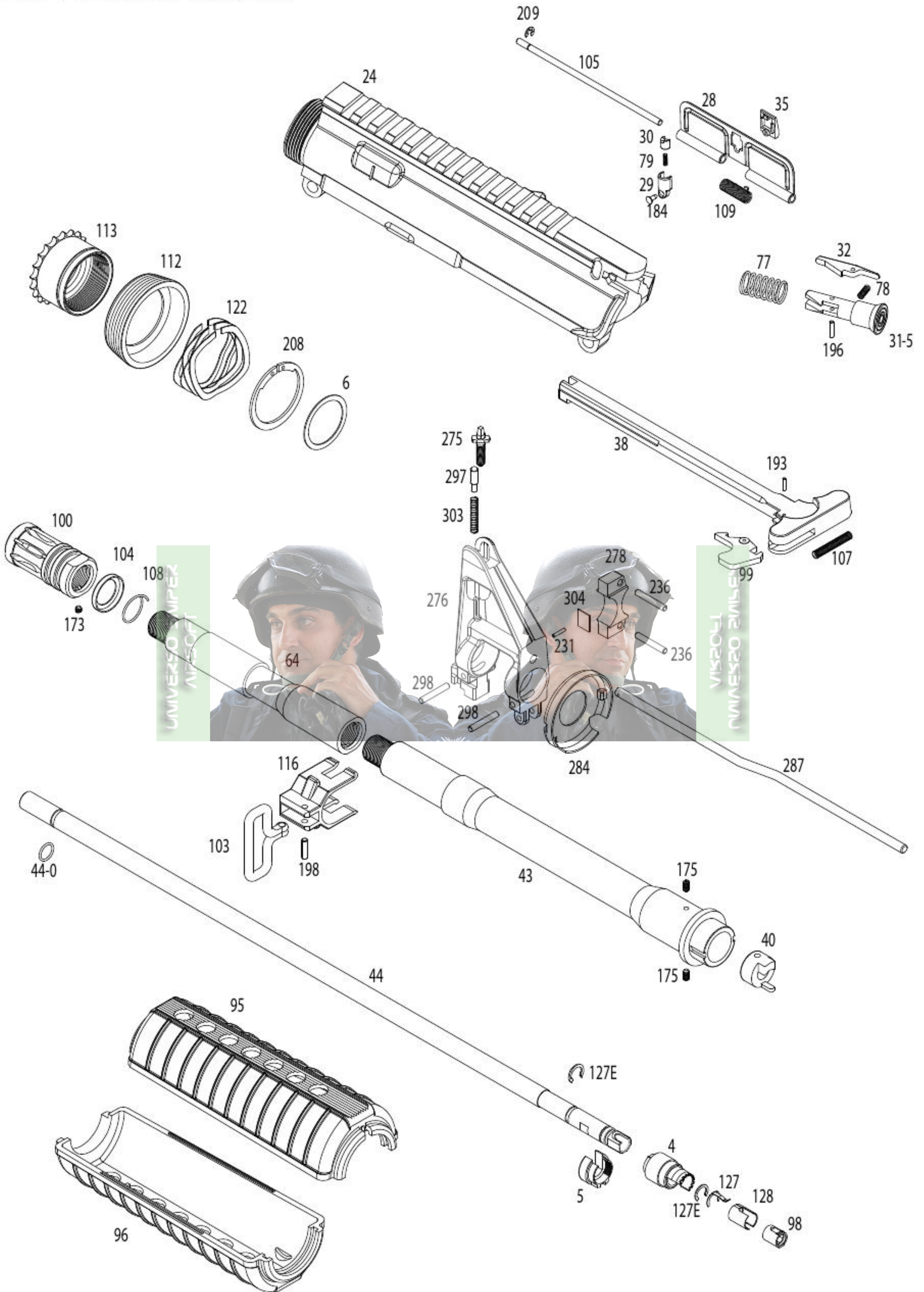

LM4 PTR PARTS DIAGRAM

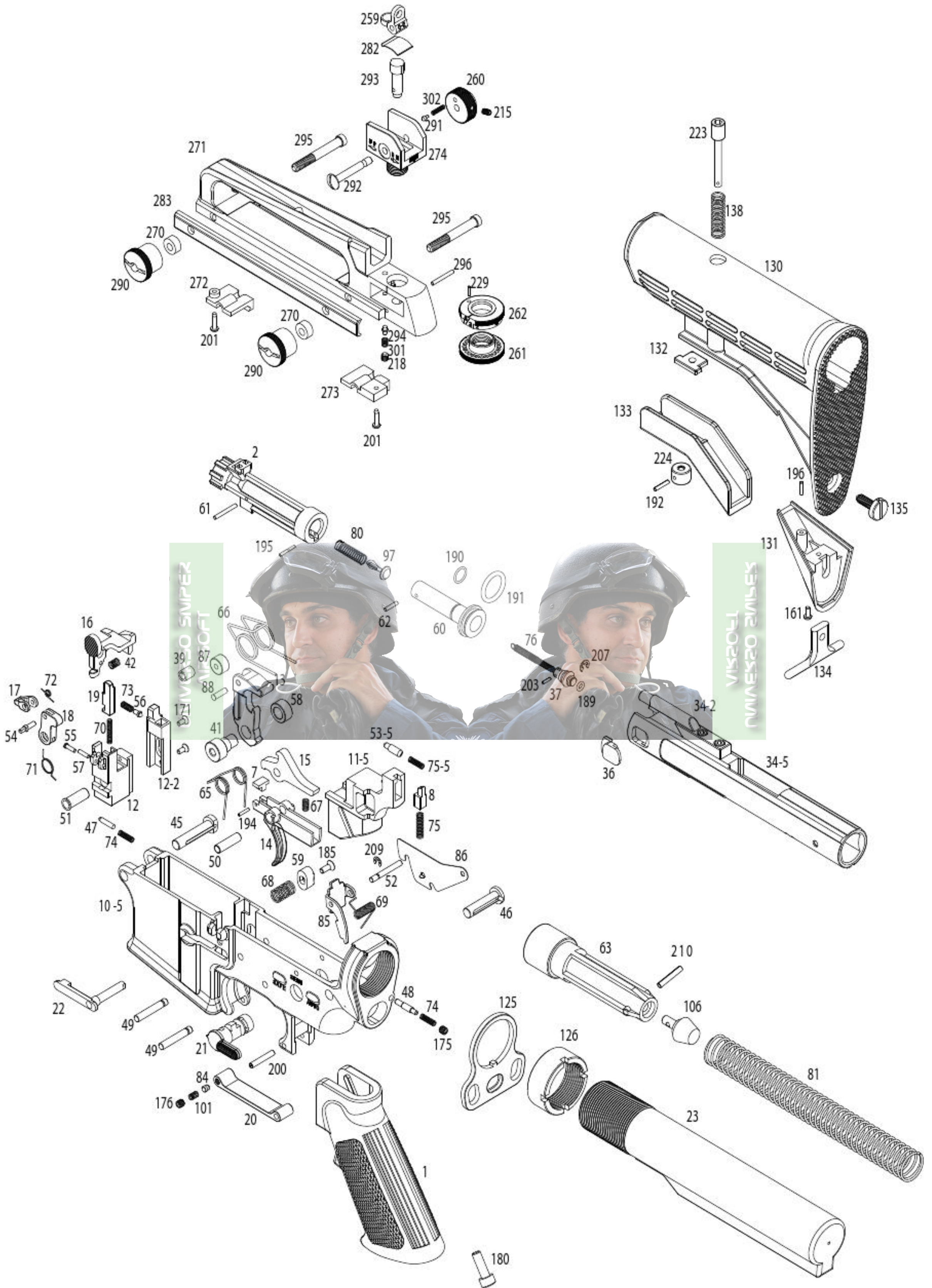

LM4 SERIES

LM4C PTR PARTS DIAGRAM

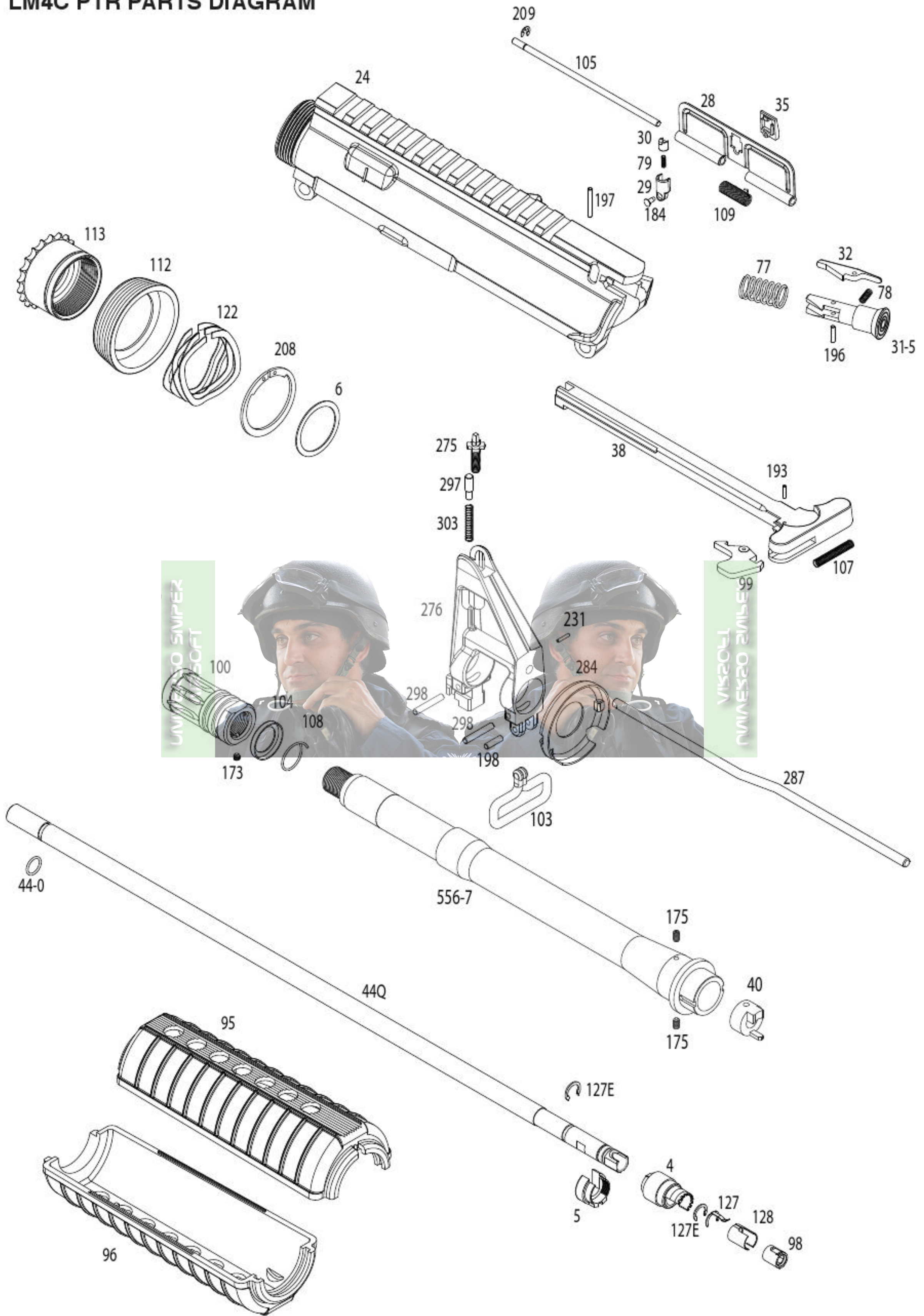

LM4C PTR PARTS DIAGRAM

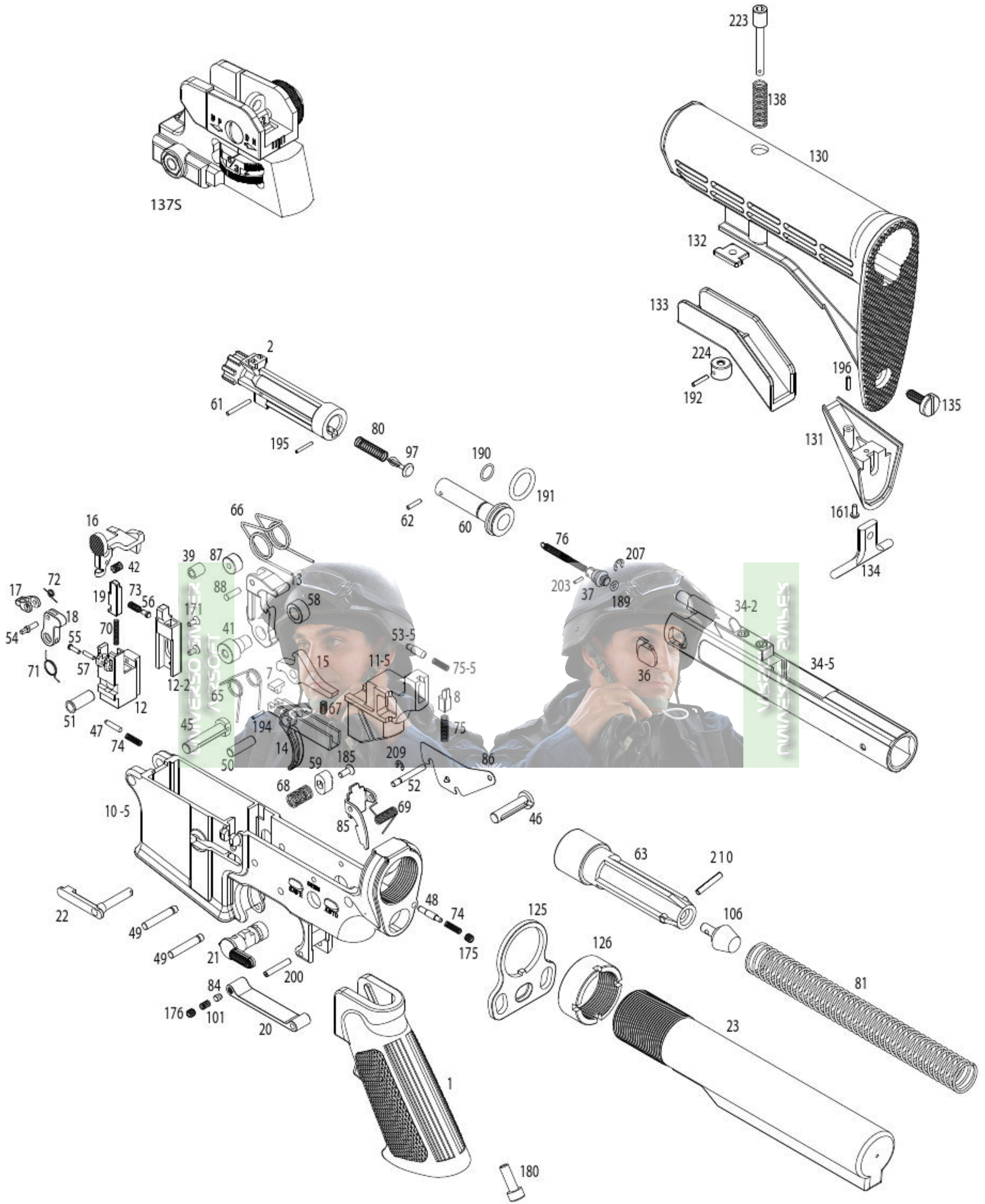

LM4 RIS PTR PARTS DIAGRAM

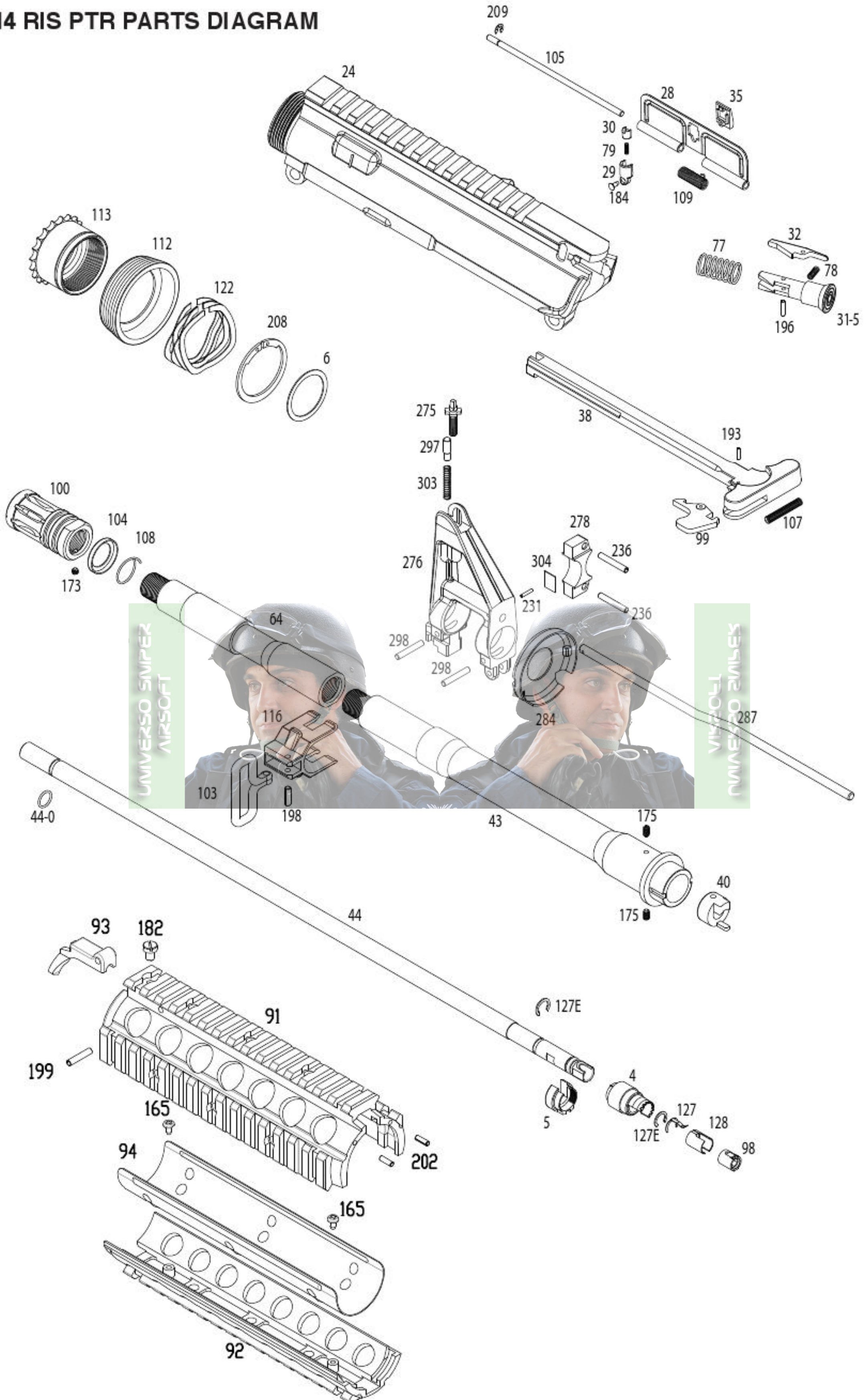

LM4 RIS PTR PARTS DIAGRAM

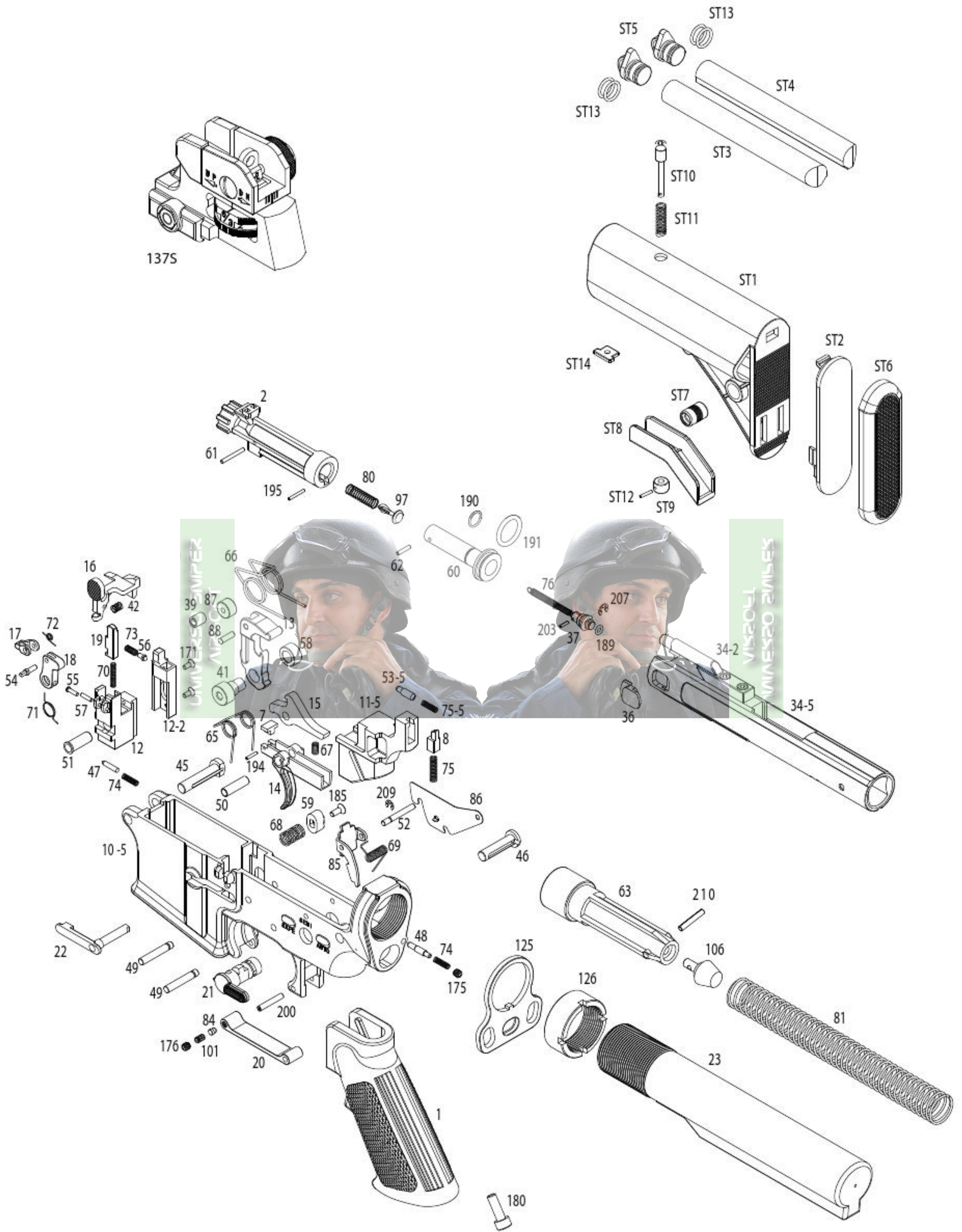

LM4 SERIES

LM4 SERIES PARTS LIST

LM4	LM4C	RIS	Part #	Description	LM4	LM4C	RIS	Part #	Description
•	•	•	1	PISTOL GRIP	•	•	•	51	IMPACT BLOCK SLEEVE
•	•	•	2	BOLT	•	•	•	52	AUTO SEAR PIN
•	•	•	4	HOP UP CYLINDER	•	•	•	53-5	SELECTOR LEVER PLUNGER
•	•	•	5	HOP UP INNER BARREL CLAMP	•	•	•	54	IMPACT HAMMER PIN
•	•	•	6	BARREL BASE WASHER	•	•	•	55	IMPACT HAMMER RESET PIN
•	•	•	7	SEAR STOP	•	•	•	56	BOLT STOP PLUNGER
•	•	•	8	RECOIL BUFFER STOP	•	•	•	57	BOLT STOP PIN
•	•	•	10-5	LOWER RECEIVER	•	•	•	58	HAMMER BUSHING
•	•	•	11-5	GRIP BASE	•	•	•	59	MAGAZINE CATCH BUTTON
•	•	•	12	IMPACT BLOCK BASE	•	•	•	60	BOLT BASE
•	•	•	12-2	IMPACT BLOCK BASE PANEL	•	•	•	61	JET NOZZLE PIN
•	•	•	13	HAMMER	•	•	•	62	BOLT BASE RETURN SPRING PIN
•	•	•	14	TRIGGER	•	•	•	63	RECOIL BUFFER
•	•	•	15	SEAR	•	•	•	64	OUTER BARREL (FRONT)
•	•	•	16	BOLT CATCH	•	•	•	65	TRIGGER SPRING
•	•	•	17	IMPACT HAMMER	•	•	•	66	HAMMER SPRING
•	•	•	18	IMPACT HAMMER BASE	•	•	•	67	SEAR SPRING
•	•	•	19	IMPACT HAMMER RESET	•	•	•	68	MAGAZINE CATCH SPRING
•	•	•	20	TRIGGER GUARD	•	•	•	69	AUTO SEAR SPRING
•	•	•	21	SELECTOR LEVER (LEFT)	•	•	•	70	IMPACT HAMMER RESET SPRING
•	•	•	22	MAGAZINE CATCH	•	•	•	71	IMPACT BLOCK RETURN SPRING
•	•	•	23	BUFFER TUBE	•	•	•	72	IMPACT HAMMER SPRING
•	•	•	24	ONE PIECE UPPER RECEIVER	•	•	•	73	BOLT STOP PLUNGER SPRING
•	•	•	28	EJECTION PORT COVER	•	•	•	74	TAKEDOWN PLUNGER SPRING
•	•	•	29	EJECTION PORT COVER LOCK TUBE	•	•	•	75	BUFFER STOP SPRING
•	•	•	30	EJECTION PORT COVER LOCK PLUNGER	•	•	•	75-5	SELECTOR PLUNGER SPRING
•	•	•	31-5	FORWARD ASSIST	•	•	•	76	BOLT BASE RETURN SPRING
•	•	•	32	FORWARD ASSIST PLATE	•	•	•	77	FORWARD ASSIST SPRING
•	•	•	34-2	CARRIER KEY	•	•	•	78	FORWARD ASSIST PLATE SPRING
•	•	•	34-5	BOLT CARRIER	•	•	•	79	EJECTION PORT COVER LOCK SPRING
•	•	•	35	EJECTION PORT COVER LOCK	•	•	•	80	JET NOZZLE SPRING
•	•	•	36	PISTON STOP	•	•	•	81	BUFFER SPRING
•	•	•	37	BOLT BASE PLUG	•	•	•	84	TRIGGER GUARD LOCK PIN
•	•	•	38	CHARGING HANDLE	•	•	•	85	FULL AUTO SEAR
•	•	•	40	INNER BARREL STABILIZER	•	•	•	86	TRIGGER ASSEMBLY PIN RETAINER
•	•	•	41	HAMMER ALIGNMENT BUSHING	•	•	•	87	HAMMER ROLLER
•	•	•	42	BOLT CATCH SPRING	•	•	•	88	HAMMER ROLLER PIN
•	•	•	43	OUTER BARREL (REAR)	•	•	•	91	TOP RAIL INTERFACE
•	•	•	44	INNER BARREL	•	•	•	92	LOWER RAIL INTERFACE
•	•	•	44Q	INNER BARREL	•	•	•	93	TOP RAIL LOCK
•	•	•	45	TAKEDOWN PIN (FRONT)	•	•	•	94	HEAT SHIELD
•	•	•	46	TAKEDOWN PIN (REAR)	•	•	•	96	UPPER HAND GUARD
•	•	•	47	TAKEDOWN PLUNGER (FRONT)	•	•	•	96	LOWER HAND GUARD
•	•	•	48	TAKEDOWN PLUNGER (REAR)	•	•	•	97	JET NOZZLE
•	•	•	49	TRIGGER ASSEMBLY PIN X2	•	•	•	98	HOP UP BUCKING
•	•	•	50	TRIGGER SLEEVE	•	•	•	99	CHARGING HANDLE LATCH

LM4 SERIES PARTS LIST (CONTINUED)

LM4	LM4C	LM4 RIS	Part#	Description	LM4	LM4C	LM4 RIS	Part#	Description
•	•	•	100	FLASH HIDER			•	199	RAIL LOCK PIN
•	•	•	101	TRIGGER GUARD PLUNGER SPRING	•	•	•	200	FRONT SIGHT HOUSING PING
•	•	•	103	SWIVEL FRONT			•	202	RAIL ALIGNMENT PINS X2
•	•	•	104	FLASH HIDER WASHER	•	•	•	203	GAS PLUG PIN
•	•	•	105	EJECTION PORT COVER	•	•	•	207	BOLT BASE PLUG E-CLIP
•	•	•	106	RECOIL BUFFER BASE	•	•	•	208	LOCKING CLAMP
•	•	•	107	CHARGING HANDLE LATCH SPRING	•	•	•	209	PIN RETAINING E-CLIP
•	•	•	108	FLASH HIDER SPRING	•	•	•	210	BUFFER PIN
•	•	•	109	EJECTION PORT COVER SPRING	•	•		223	STOCK LEVER BOLT
•	•	•	112	DELTA RING	•	•		224	STOCK LEVER RETAINER NUT
•	•	•	113	BARREL NUT	•			231	GAS TUBE PIN
•		•	116	SWIVEL BASE	•		•	236	SWIVEL BASE LOCK ROLL PIN X2
•	•	•	122	DELTA RING LOCK SPRING	•			270	KNOB SPACER
•	•	•	125	REAR SLING LOOP	•			271	CARRY HANDLE
•	•	•	126	BUFFER TUBE CASTLE NUT	•			272	CARRY HANDLE BASE COVER
•	•	•	127E	RETAINING C-CLIP	•	•	•	275	FRONT SIGHT POST
•	•	•	128	HOP UP COVER	•	•	•	276	FRONT SIGHT BASE
•	•		130	RETRACTING STOCK	•		•	278	SWIVEL BASE LOCK
•	•		131	STOCK SLING MOUNT COVER	•			283	CARRY HANDLE LOCKING RAIL
•	•		132	STOCK LEVER SPACER	•	•	•	284	FRONT HANDGUARD RING
•	•		133	STOCK LEVER	•	•	•	287	GAS TUBE
•	•		134	STOCK SLING MOUNT	•	•		290	CARRY HANDLE KNOB
•	•		135	STOCK SLING MOUNT SCREW	•	•		297	FRONT SIGHT PLUNGER
•	•	•	137S	REAR SIGHT	•	•	•	298	FRONT SIGHT HOUSING PINS
•	•	•	138	STOCK LEVER BOLT SPRING	•	•	•	303	FRONT SIGHT SPRING
	•	•		REAR SIGHT LOCK	•		•	304	SWIVEL BASE SPACER
•	•		161	SLING MOUNT COVER SCREW		•		556-7	OUTER BARREL 1 PC
		•	165	HEAT SHIELD SCREWS X2			•	ST1	STOCK
•	•	•	171	IMPACT BLOCK SCREWS			•	ST2	BUTT PAD BASE
•	•	•	173	FLASH HIDER/TAKEDOWN SET SCREW			•	ST3	BATTERY TUBE (LEFT)
•	•	•	175	STABILIZER SCREW			•	ST4	BATTERY TUBE (RIGHT)
•	•	•	176	TRIGGER GUARD SET SCREW			•	ST5	BATTERY TUBE PLUG
•	•	•	180	PISTOL GRIP SCREW			•	ST6	BUTT PAD
		•	182	RAIL LOCK SCREW			•	ST7	QD SWIVEL MOUNT
•	•	•	184	EJECTION PORT COVER SCREW			•	ST8	STOCK LEVER
•	•	•	185	MAGAZINE CATCH SCREW			•	ST9	STOCK LEVER NUT
•	•	•	189	BOLT BASE PLUG O-RING			•	ST10	STOCK LEVER BOLT
•		•	190	BOLT BASE O-RING (SMALL)			•	ST11	STOCK LEVER SPRING
•	•	•	191	BOLT BASE O-RING (LARGE)			•	ST12	STOCK NUT PIN
•	•		192	LEVER RETAINER NUT PIN			•	ST13	BATTERY TUBE PLUG
•	•	•	193	CHARGING HANDLE LATCH PIN			•	ST14	STOCK LEVER SPACER
•	•	•	194	GAS TUBE PIN					
•	•	•	195	BOLT BASE PIN					
•	•	•	196	RETAINING PIN					
•	•	•	197	FORWARD ASSIST PIN					
•	•	•	198	FRONT SWIVEL PIN					



KWA Performance Industries, Inc.

18571 E. Gale Ave.
City of Industry, CA 91748

T: (626) 581-1777 • F: (626) 581-0777

WWW.KWAUSA.COM

Copyright © August 2015 KWA Performance Industries, Inc. All Rights Reserved.