

KWA®

OPERATOR'S MANUAL

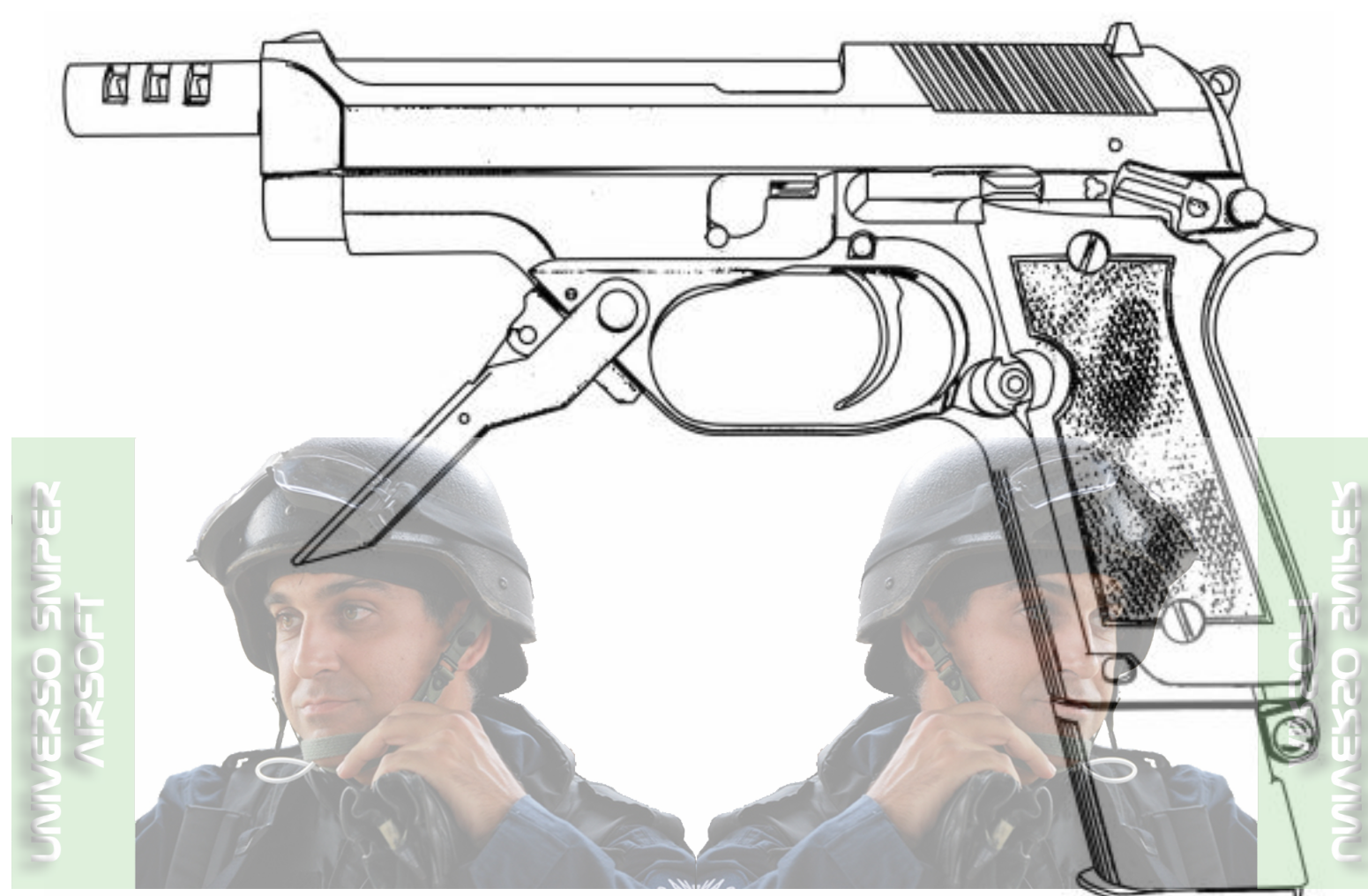

M93R II NS2

TABLE OF CONTENTS

Use of this manual.....	2
Safety Guidelines	2-3
Specifications	4
Package Contents	4
Charging Gas	5
BB Loading	6
Loading Magazine	7
Loading Chamber	7
Safety	7
Shooting	8
Shooting Modes	8
Open Slide	9
After Shooting	9
Hop-Up System	9
Hop-Up Adjustment Point	10
Disassembly	10
Assembly	11
Troubleshooting	12
General Maintenance	13
Operating Under Unusual Conditions.....	14
Diagrams and Parts Lists	15-18



USE OF THIS MANUAL

Before operating the Airsoft gun, read this manual in its entirety. Important safety topics and tips are discussed throughout all of the chapters. It's important that the operator know the principles of gun handling safety and operation prior to firing the Airsoft gun.

SAFETY GUIDELINES



WARNING! Failure to follow safety guidelines may result in serious injury.

Safety Distance

The effective shooting range is approximately 75 feet. BBs fired from this Airsoft gun may travel further than intended. Make certain that you have an adequate backstop.

Eye Protection

Eye protection should be worn at all times when both shooting and maintaining your Airsoft gun. Protect your eyes from silicone spray and BBs under spring pressure while performing maintenance on your Airsoft gun.

Assume Every Gun is Always Loaded

Until you are certain the chamber is empty, treat every gun as if it were loaded. Do not assume the chamber is empty based on your memory or someone else's words. Always remove the magazine and visually check to confirm the chamber is empty.

Beware of Barrel Obstructions

Ensure the Airsoft gun barrel is free of obstructions before you fire the gun. Even the smallest obstruction such as lubrication or a stuck cleaning patch can cause a misfire or malfunction.

Muzzle Control

Always keep the muzzle of the gun pointed in a safe direction. Never point the muzzle at a person or object that you do not intend to shoot.

Keep Your Safety On

Keep the gun's safety on until your sights are aligned on your target and you are ready to fire.

Keep Your Finger Off The Trigger

Keep your finger off the trigger and out of the trigger guard until your sights are aligned on your target and you are ready to fire.



WARNING! Airsoft BBs can be a choking hazard. Keep them away from children.

SAFETY GUIDELINES

Identify Your Target and Backstop

Before you pull the trigger, make certain of your target and what is beyond it. The Airsoft gun should never be fired at surfaces such as rocks, glass, water, or other hard surfaces where BBs are likely to ricochet in unpredictable directions.



WARNING! Adult supervision is required for any person under the age of 18.

Failure To Fire

If the Airsoft gun fails to fire, misfires, or malfunctions, do not look into the gun barrel. BBs can become lodged into the chamber, and serious eye injury may occur.

Maintain Your Gun Properly

Performing proper maintenance, as outlined in this manual, ensures that your Airsoft gun will be safe to shoot and will perform to its designed specifications for many years. Alterations, modifications or adjustments may damage your Airsoft gun, make it unsafe to shoot, and will void all warranty claims.

Store Your Gun Safely

Always store the Airsoft gun in a safe place, and out of the reach of children. Always transport the Airsoft gun in a carrying case. Never display the Airsoft gun in a public place. Keep the safety engaged, and remove the magazine before storing the Airsoft gun. Note: it is your responsibility to take every reasonable precaution to ensure the safe storage and transportation of your Airsoft gun.

Orange Tip

The orange tip on Airsoft guns helps Law Enforcement distinguish between the replica guns from their real firearm counterparts. Altering the coloration or markings required by state or Federal law so as to make the product look more like a firearm is dangerous and may be a crime. Operator assumes all risks and responsibility when doing so.

Hazards of Being Mistaken for a Real Firearm

Airsoft guns have been mistaken by Police and Law Enforcement as real firearms. A confrontation with law enforcement while carrying an Airsoft gun can result in serious injury or even death. It is strongly advised to operate the Airsoft gun at a safe and legal location. In the event that you are approached by Law Enforcement personnel, you must comply with their instructions immediately to avoid an incident.

Alcohol, Medications, and Drugs

Do not handle or operate your Airsoft gun while under the influence of alcohol, medication or drugs.

Your Responsibility

Your Airsoft gun is well-engineered and manufactured to the highest standards. It was carefully inspected before it was packaged and shipped from our factory. Its safe use depends on you alone. You are the ultimate safety device. Like many other devices, your Airsoft gun is safe unless handled in an irresponsible or uneducated manner.

SPECIFICATIONS

- Overall Length = 25.3 cm [9.96"]
- Overall Height = 17.5 cm [6.89"]
- Inner Barrel Length = 125 mm
- Inner Barrel Diameter = 6.05 mm
- Weight = 1.06 kg [2.34 lbs]
- Caliber = 6 mm
- Magazine Capacity = 32 [48] rounds
- Velocity = 104-107 MPS [340-350 FPS]
- Energy Output with 0.20g BB = 1.07 Joules
- Gas System = NS2
- Propellant = Green Gas

Special Features:

- Realistic construction and field stripping
- Full metal alloy construction
- Functional safety
- Integrated flip down front handle
- Semi-Auto and three round selective fire
- Adjustable hop-up

*Individual test results may vary depending on brand of BBs, ambient temperature, and chronograph used.

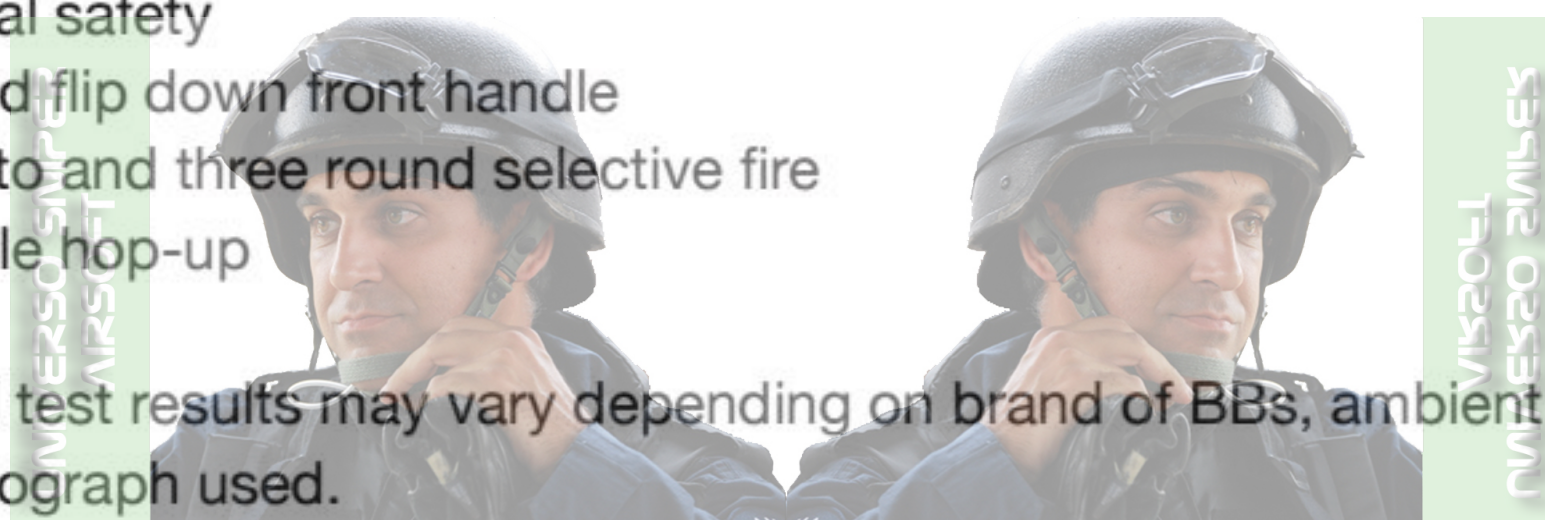

PACKAGE CONTENTS

- 1 M93R II NS2 Airsoft gun
- 1 Bottle of Silicone Oil
- 1 Hi-Cap Magazine
- 1 Sample bag of Airsoft BBs
- 1 Hop-Up Adjustment Tool
- 1 Operator's Manual



CHARGING GAS

1. Release the magazine by pressing the magazine catch button.
2. Push the gas canister nozzle into the charging valve. (Make sure both the canister and magazine are inverted and in the vertical position when charging.)
3. Charge the magazine until gas overflows from the charging valve.



WARNING: Avoid dropping the magazine. Sudden impact with a hard surface may cause damage to the magazine.

Note: It is normal to have minor leaking from the charging valve during charging due to high pressure built up inside the magazine. It is recommended to keep the gas release valve slightly oiled. Room temperature is the ideal temperature for shooting. You may experience a delayed action if the surrounding temperature drops below 68° F.

Note: Do not expose the magazine to direct sunlight or incinerate the magazine, as this may cause the magazine to burst. It is strongly recommended to empty the gas from the magazine after shooting. Be certain that the gas does not make contact with eyes or skin while being released, as any contact will cause cold burns.

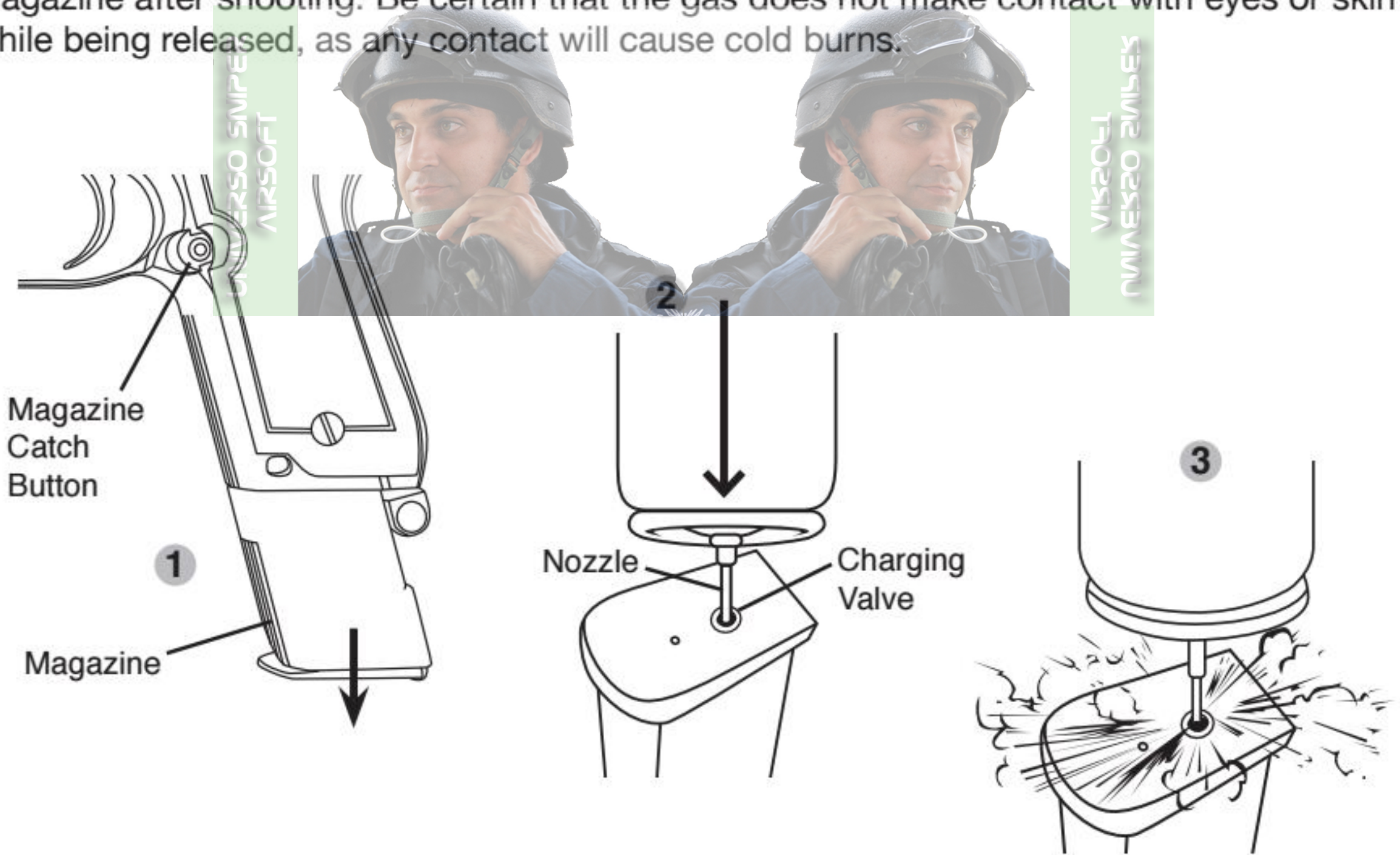

Green Gas safety tips:

- Check the canister for any cracks or leaks before using.
- Do not expose the canister to temperature over 104° F.
- Do not leave the canister directly over fire.
- Do not heat the canister.
- Keep the canister away from direct sunlight.
- Do not leave the canister in any type of vehicle.

LOADING BBs

1. Pull the magazine follower down until it locks.
2. Insert BBs into the magazine lip.
3. Make sure to have a 3mm clearance between BBs and the top lip of the magazine.
4. Push the magazine follower lock to release.



WARNING: Always use high quality 6mm BBs, weighing 0.2g or heavier. For best result use 0.25g KWA Perfect BBs. Never use recycled or low grade BBs to prevent damage to your gun.



WARNING: Do not release the magazine follower when the magazine is empty. Doing so will damage the magazine and magazine follower.

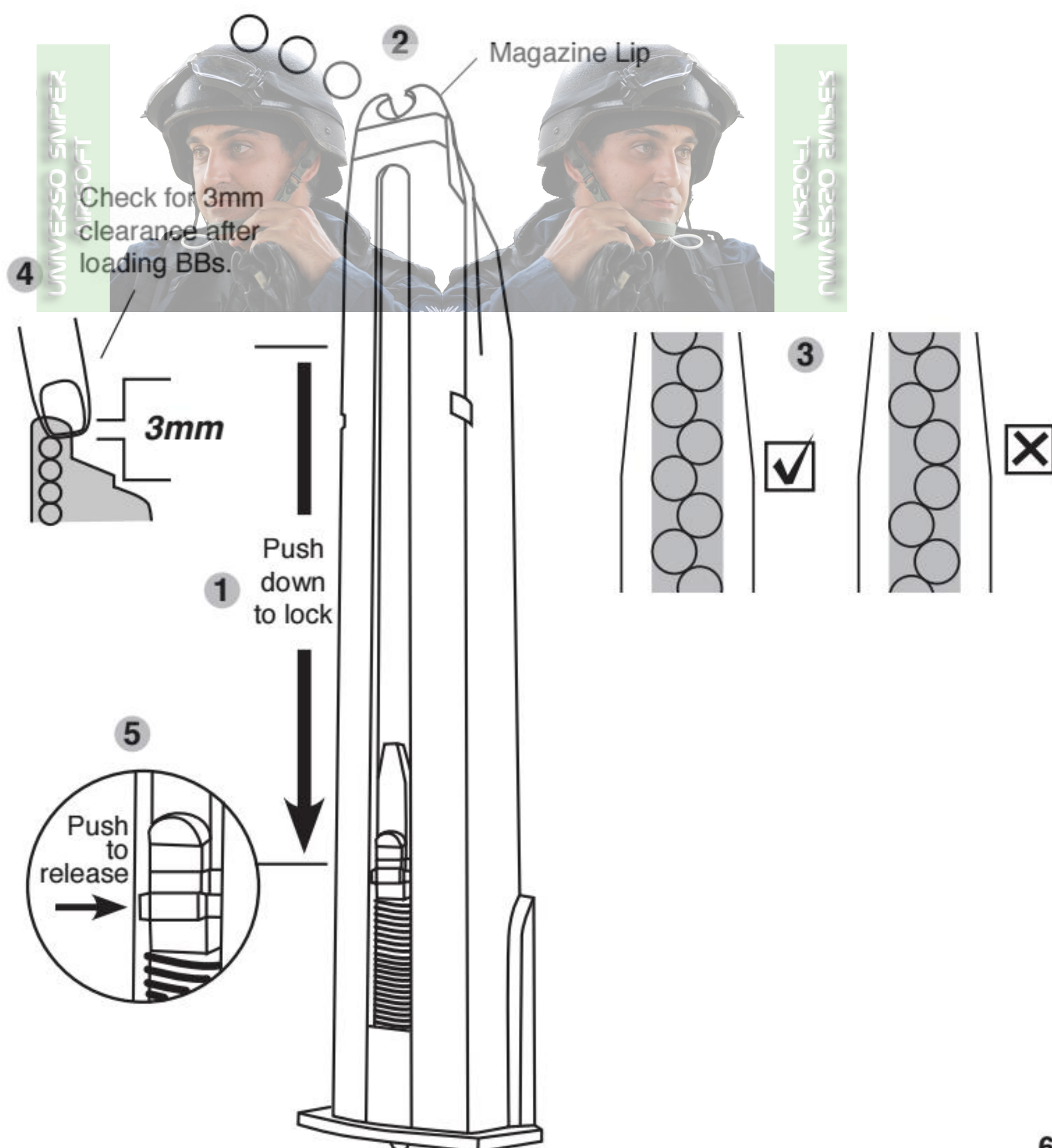

LOADING MAGAZINE

1. Place the magazine back into the magazine well.
2. Push the magazine up until it clicks into a locked position.
3. Pull the magazine down to assure that it has been locked in place.

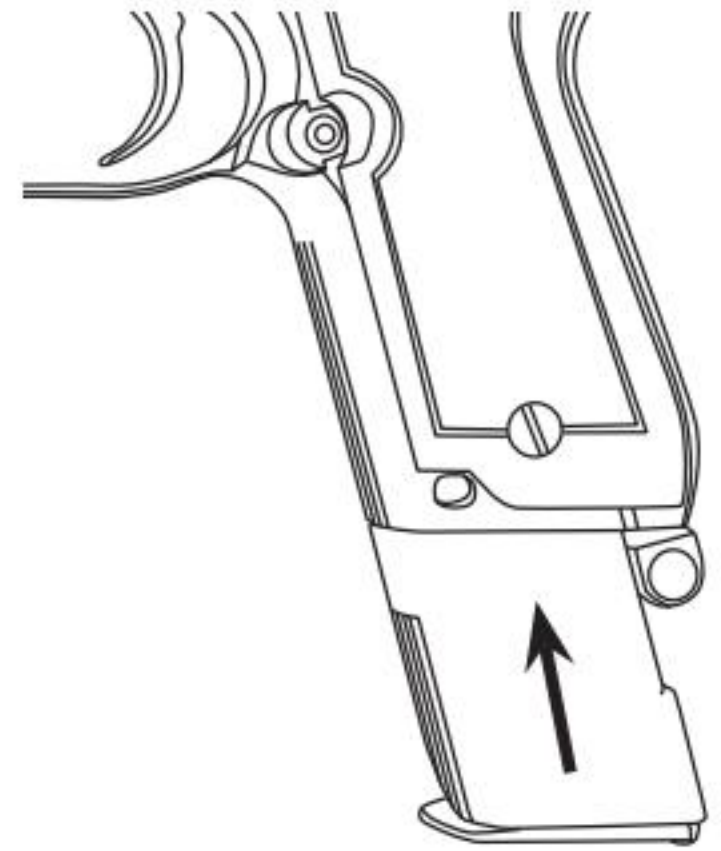

LOADING CHAMBER

Pull the slide to the rear-most position and release the slide. This will automatically load the BBs into the chamber. The hammer will be in a cocked position. Make sure not to skip this procedure. Skipping this step will cause a misfire on the first pull of the trigger. The slide will stay open when the last BB is fired and ejected.

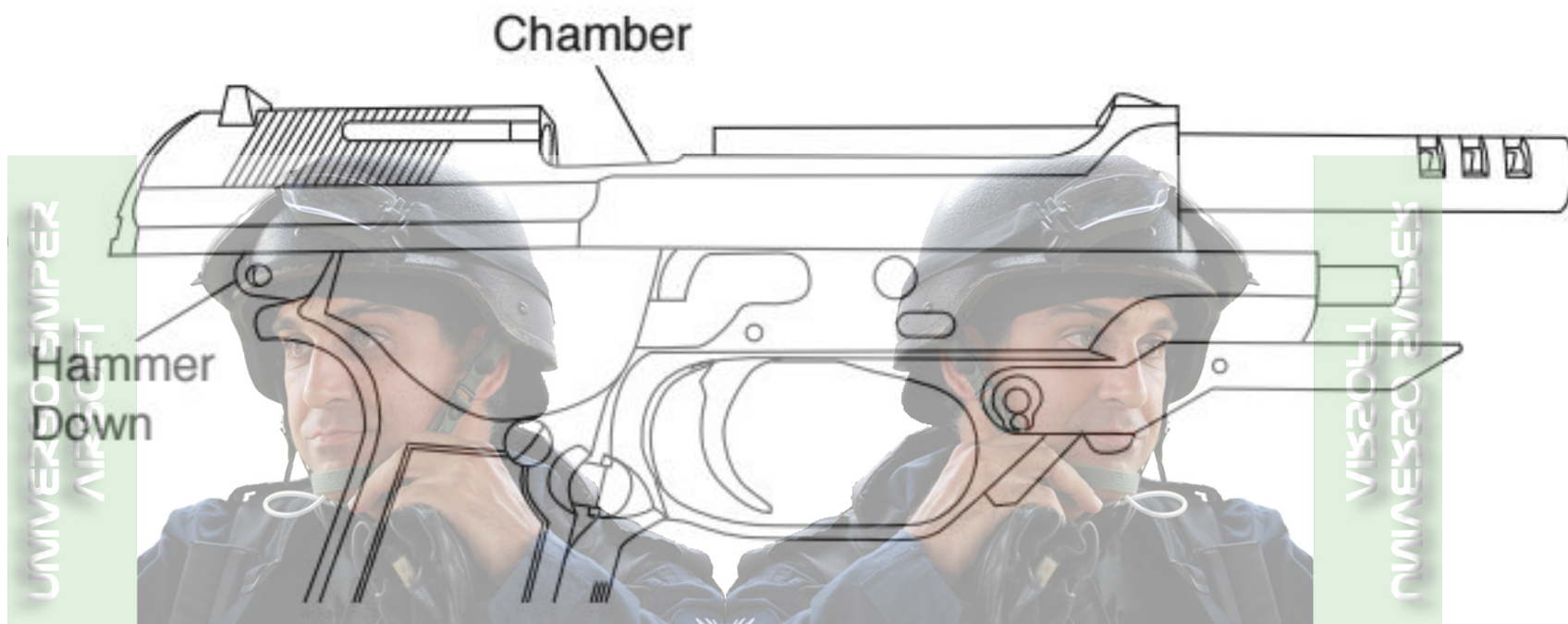

SAFETY

To engage the Safety, cock the hammer back and push down on the safety lever. The gun is not ready to fire.
(DOWN = ON = NOT READY TO FIRE)

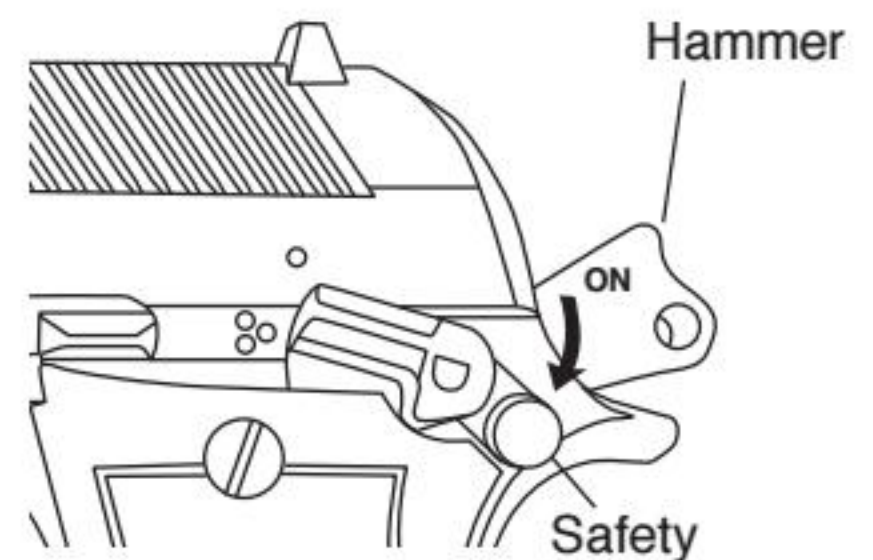

To disengage the Safety, push up on the safety lever. The gun is ready to fire.
(UP = OFF = READY TO FIRE)

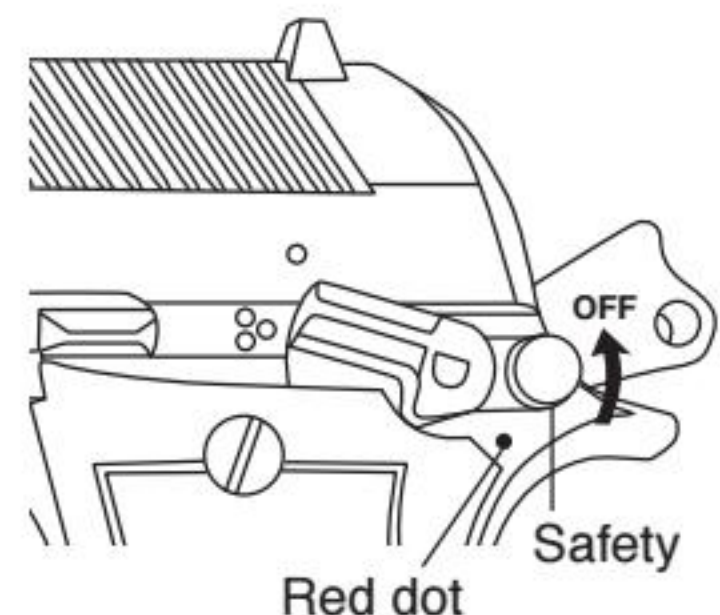

WARNING: After decocking the hammer, you can still shoot with double action if the safety is disengaged.

SHOOTING

1. Make sure the gun is cocked.
2. Grasp the Airsoft gun in your hand firmly. A two-hand hold with one hand wrapped around the other will help control the Airsoft gun.
3. Release safety and squeeze the trigger. The blow back action will load the following BBs automatically as the slide cycles back and forth.



WARNING: Never shoot the gun in a horizontal or upside-down position.



WARNING: Do not fire the pistol without a magazine inserted. Doing so may damage the impact block and result in the loss of the impact pin.

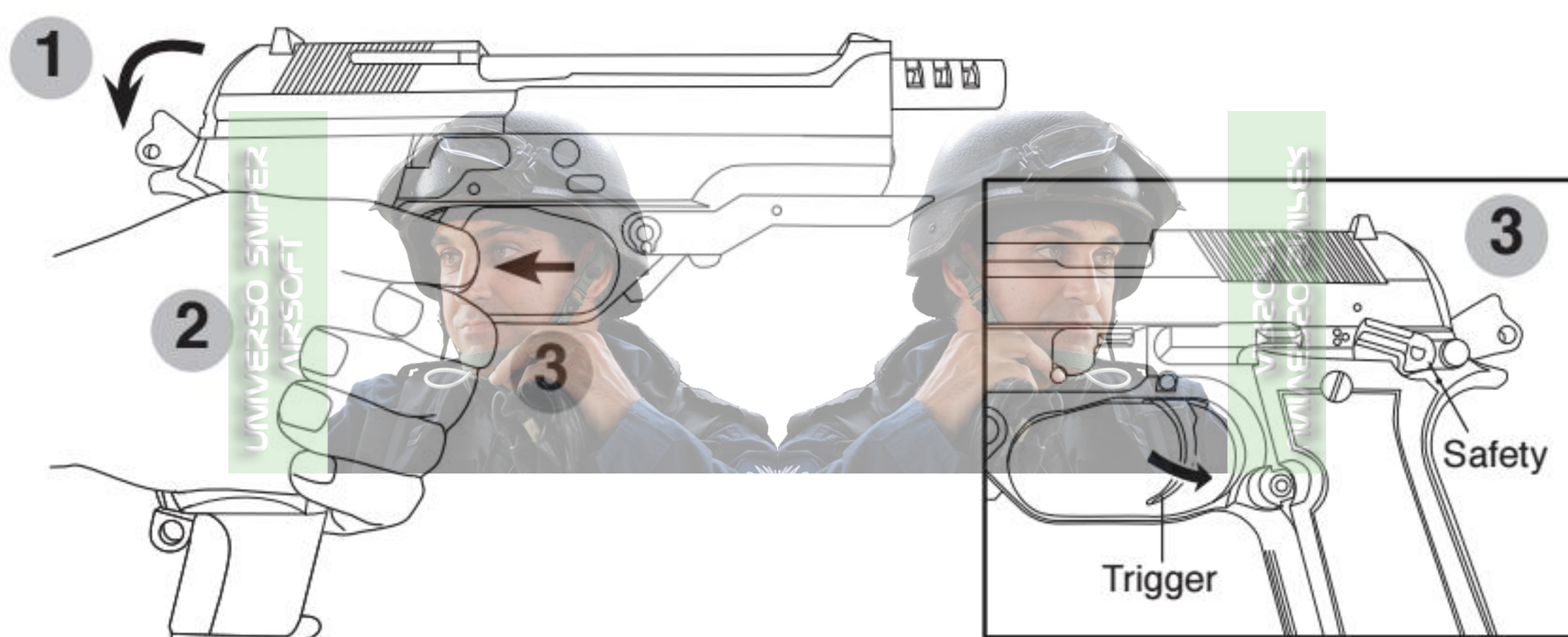

SHOOTING MODES

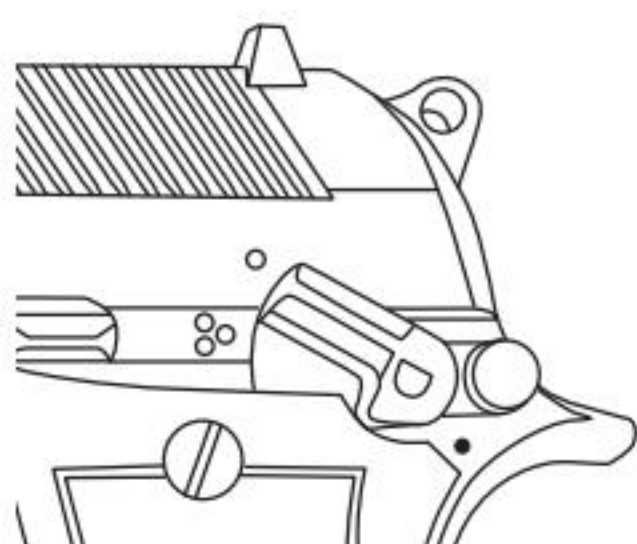

Single Action Mode

Align the selector lever with the single white dot.

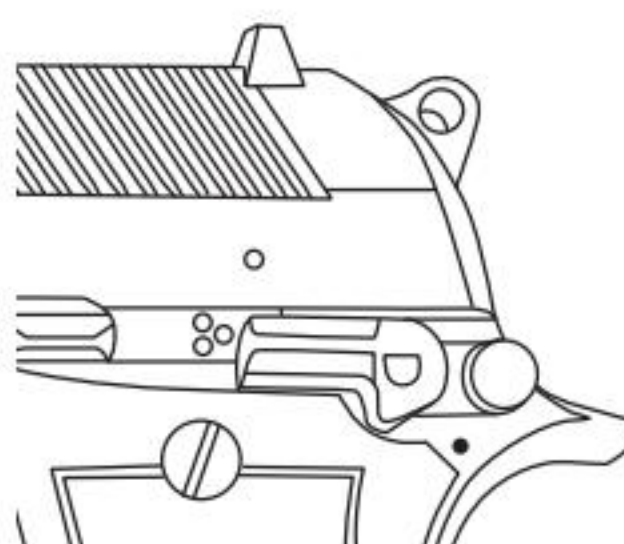

3 Round Burst Mode

Align the selector lever with the group of 3 white dots.

OPEN SLIDE

The slide will remain open after the last BB has been fired and ejected. Remove the empty magazine and replace it with a loaded magazine, then release the slide stop. The first BB will be automatically loaded into the chamber.

Note: It is important to treat your gun as if it were loaded even when the slide is open.

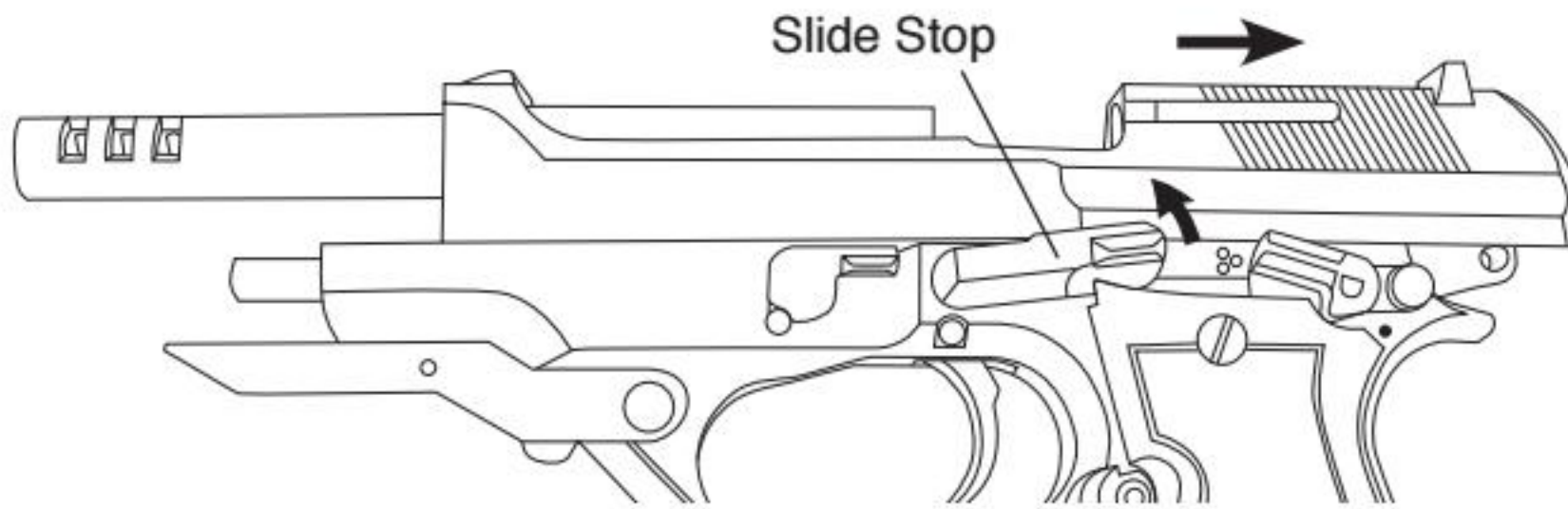

AFTER SHOOTING

After you are finished shooting, remove the magazine and visually examine the open chamber to check for clearance. Make sure both the magazine and the chamber are clear without BBs, **then engage the safety lever.**

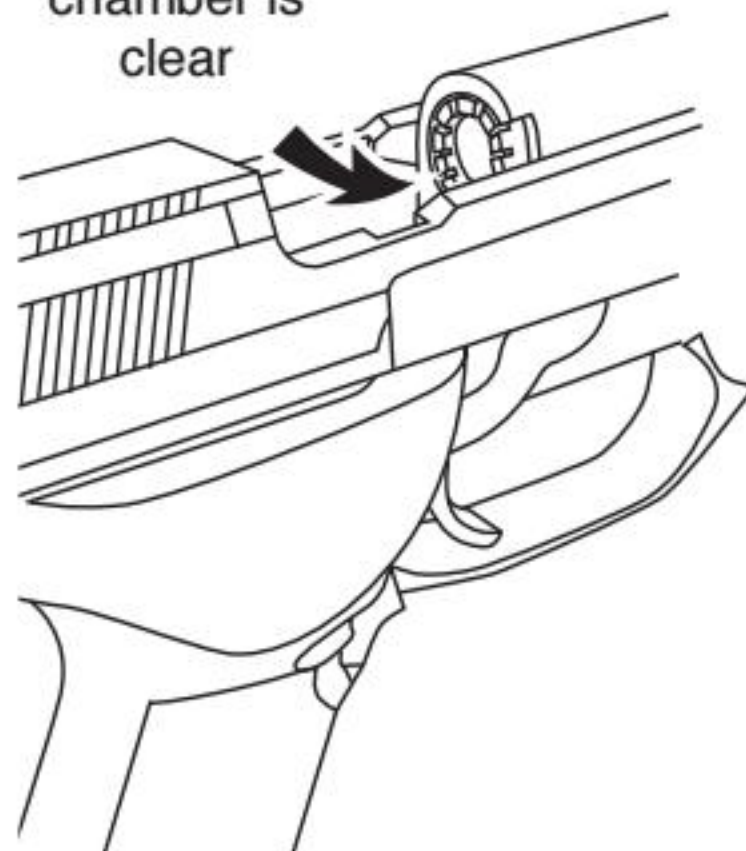

HOP-UP SYSTEM

The Hop-Up device is one of KWA's standard features, giving Airsoft BBs greater stability, further travel and increased accuracy. Airsoft BBs are light-weight and can be affected by wind when fired. With the Hop-Up system, the trajectory of the Airsoft BBs can be adjusted according to the shooting environment or surroundings.

HOP-UP ADJUSTMENT

To adjust the Hop-Up, make sure the magazine is loaded and that you have at least 65 feet of clearance for a test fire before making any adjustments.

1. Test fire the gun for 10 to 20 rounds and observe the BB's traveling pattern.
2. Remove the magazine.
3. Open the slide and place adjusting tool into the slotted chamber ring. Turn the adjusting ring a 1/4-inch at a time.
4. If the BBs are dropping too quickly, move the adjusting ring to the left or counter-clockwise to give the BB more hop. If the BBs are dropping too slowly, move the adjusting ring to the right or clock-wise.
5. Test fire and adjust as needed.

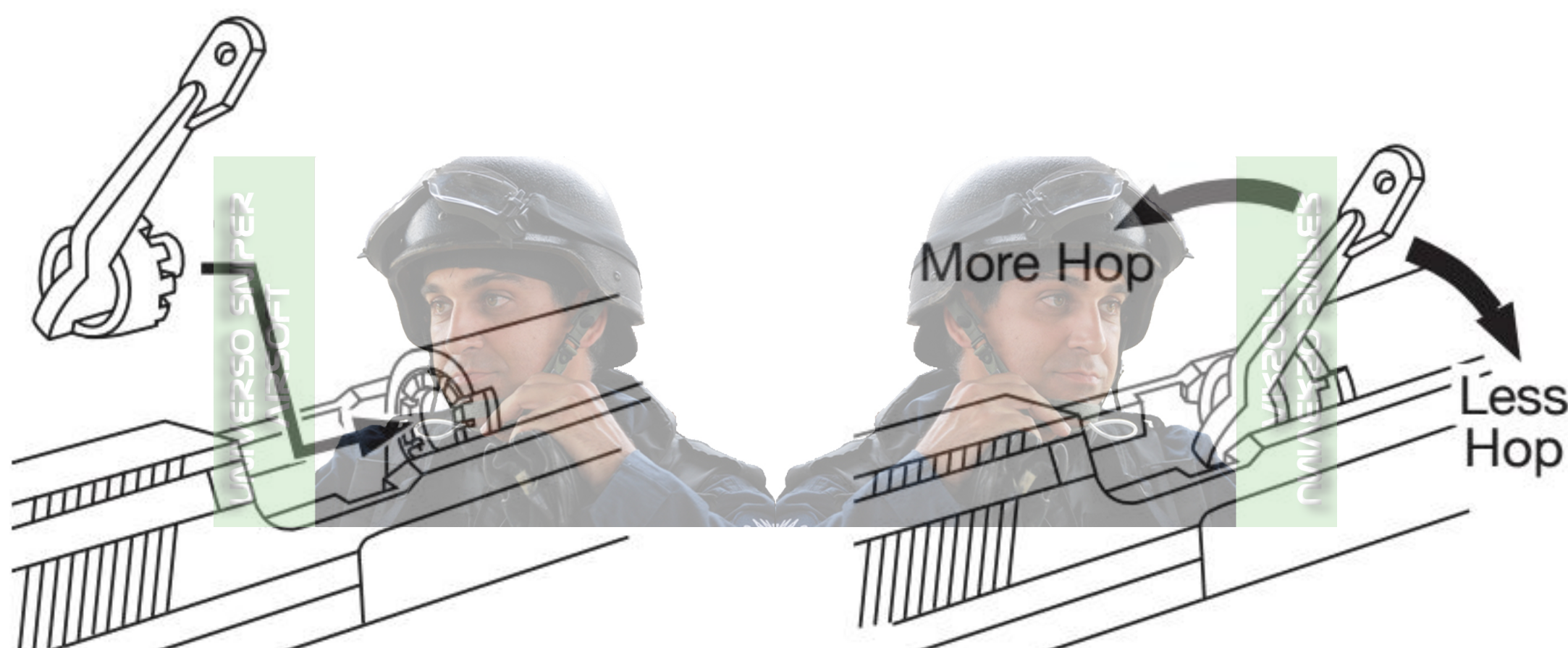

HOP-UP ADJUSTMENT POINT

HOP UP EFFECTIVENESS	BB TRAJECTORY PATTERN	ADJUSTMENTS
NOT EFFECTIVE	BB DROPS FREELY	TURN KNOB TO LEFT
SLIGHTLY	BB TRAVELS AT SHORT TRAJECTORY PATH	TURN KNOB SLIGHTLY TO LEFT
PROPERLY	BB TRAVELS DISTANCE AT FLAT TRAJECTORY PATH	NO ADJUSTMENT MADE
OVERLY	BB TRAVELS FLAT IN SHORT DISTANCE, THEN GOES UP IN CURVE AND DROPS FREELY	TURN KNOB SLIGHTLY TO RIGHT
EXTREMELY EFFECTIVE	BB TRAVELS AT UNSTABLE SPEED AND IRREGULAR PATH	TURN KNOB TO RIGHT

DISASSEMBLY

It is not recommended to disassemble the gun unless for general maintenance, or to clear BBs jammed inside the barrel.

1. Remove the magazine by depressing the magazine catch on either side of the Airsoft gun.
2. Check and clear the chamber of BBs.
3. Press the disassembly button from the right side of the frame and turn the disassembly lever downward from the left side of the frame.
4. Glide the slide forward slowly away from the frame. The recoil spring and guide rod will pop loose.
5. Remove the guide rod and recoil spring.
6. Slide the barrel out from underneath the slide.

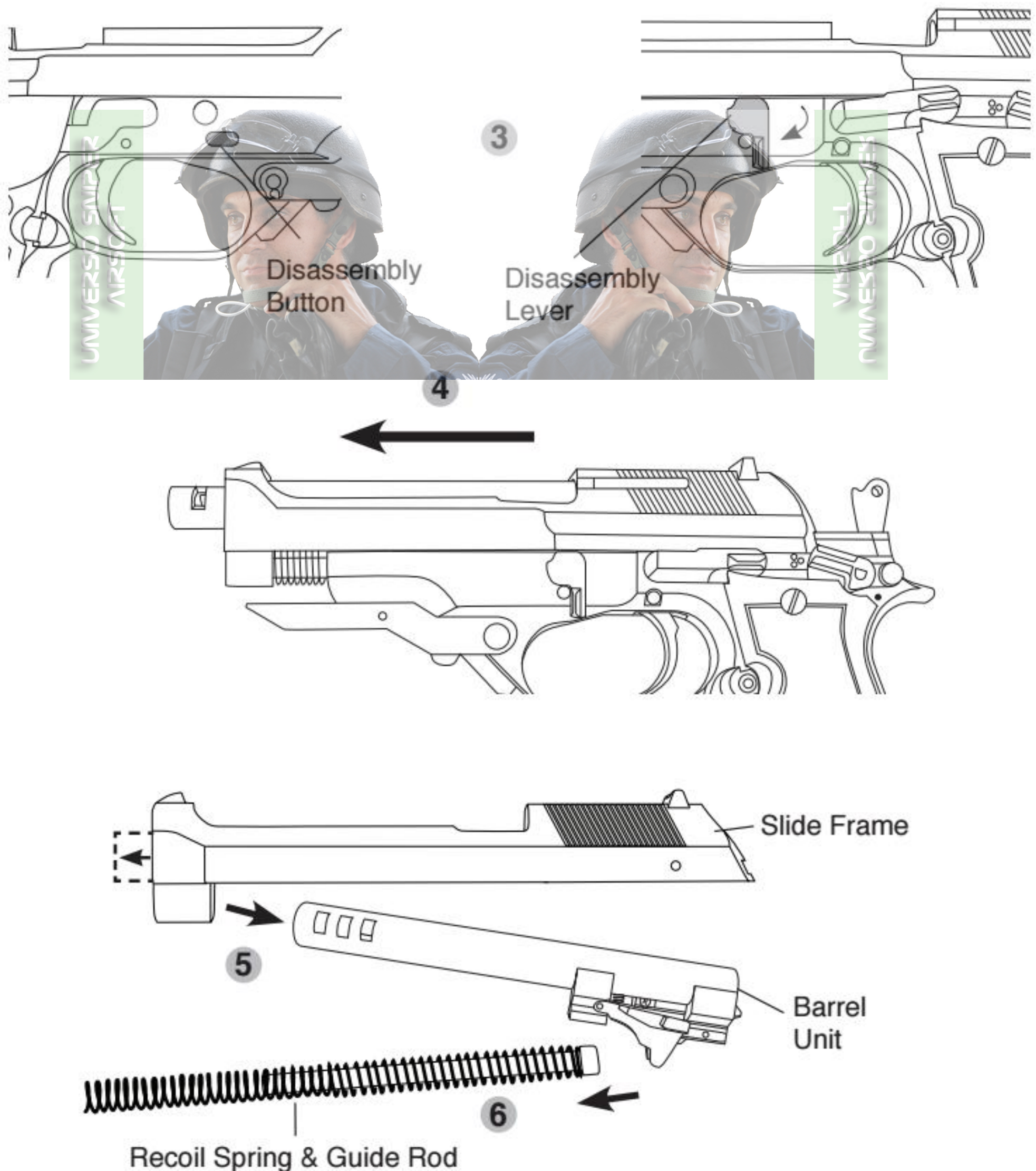

ASSEMBLY

1. Place the barrel into the slide.
2. Install the recoil spring and guide rod into position.
3. Keep pressure on the spring and guide. Put the assembled slide onto the frame rails and glide it toward the rear of the gun.
4. Swing the disassembly lever upward.
5. Pull the slide to rear most position and then release.

NOTE: After assembly is completed, cycle the slide back and forth to ensure proper assembly.

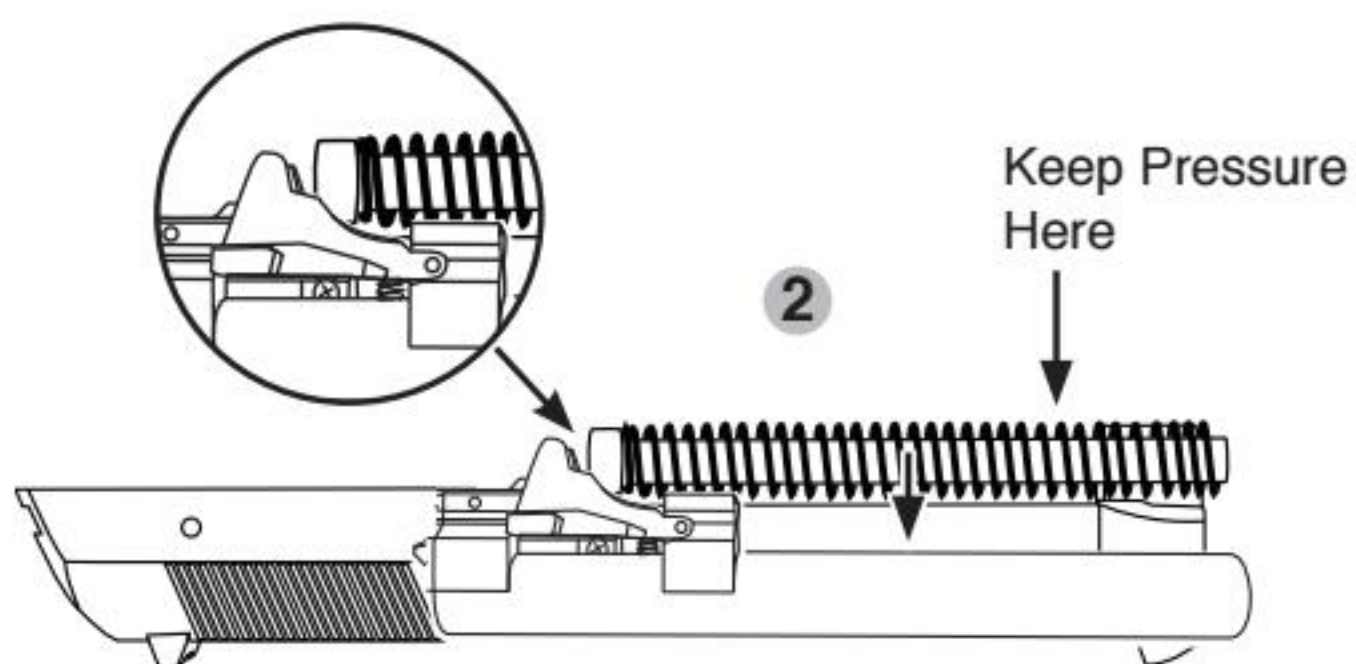
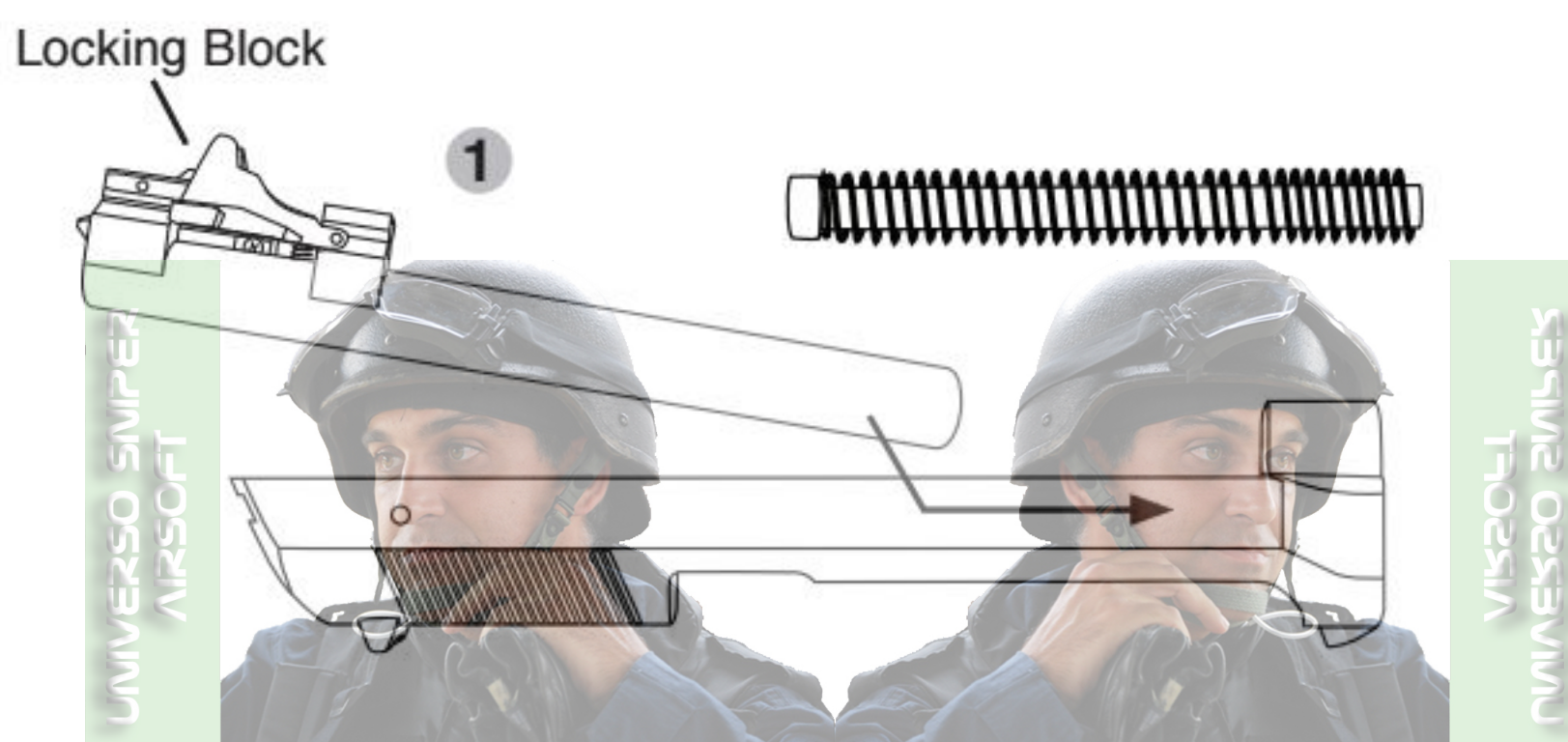

BASIC TROUBLESHOOTING GUIDE FOR PISTOL

SYMPTOMS	POSSIBLE CAUSE	SOLUTIONS
Slide jams / Will not complete cycle	Dry internals	Add silicone to cylinder / main seal/ rails
Double feeds BBs into chamber / BB's roll out of barrel	Hop-up adjustment too tight	Release hop-up or replace bucking
BBs will not release from magazine / bent mag lip/ check bb condition	Bent magazine lip	Replace magazine lip
Leaking release valve & charging valve	Dry O-ring	Add silicone oil to valves / Replace valves
Slide stop engages while shooting BBs	Weak slide stop spring	Adjust tension
Magazine base plate will not lock	Broken base plate lock	Replace base plate lock
Magazine base leaking air	Worn out base seal	Replace magazine base seal
Cylinder will not load BBs into chamber	Broken cylinder tap	Replace cylinder
Trigger will not reset	Worn out trigger spring / trigger bar spring	Replace trigger spring / trigger bar spring



GENERAL MAINTENANCE FOR KWA GAS BLOW BACK

Green gas is a liquid propellant which tends to dry out the seals and o-rings. With lubricating silicone oil, it will extend the life of the seals and o-rings and prevent gas leaks.

Use only the recommended 100% silicone oil, available for purchase at the Airsoft dealer where you purchased your KWA products. Any other type of lubricant may damage the products.

Lightly lubricate the recoil spring, cylinder and moving parts with a few drops of oil. Lubricating the seals and o-rings are essential. Unload BBs from the magazine. Make sure the magazine is free of gas before lubricating the magazine's charging valve and release valve.

OPERATING UNDER UNUSUAL CONDITIONS

Unusual conditions are defined as any condition requiring special maintenance. Perform maintenance outlined for the climate similar to your operational area

Extreme Cold:

Operating an Airsoft gas gun in extremely cold temperatures is not recommended. Cold temperatures will cause the Hop-up Bucking to harden, reducing its effectiveness. Gas will not expand properly in cold temperatures, so both the cycling rate and power will be dramatically reduced.

Extreme Heat:

Operating an Airsoft gas gun in extremely hot temperatures is also not recommended. Leaving the gun in direct sunlight for long periods of time, or operating in extremely hot areas will cause the gas to over-expand, damaging the internal workings of the gun. The increase in internal pressure from the expanding gas can also damage the seals and cause leaks in the magazine.

Dust or Sand:

Dust or sand can get into a gas gun and cause malfunctions and/or excessive wear. Keep the gun covered whenever possible. Use lubricant sparingly, as lube naturally attracts dirt and other particles. After use in a dusty area, always field strip the gun (refer to Disassembly Section) and clean any areas you can reach with a soft, lint-free cloth.



DIAGRAM

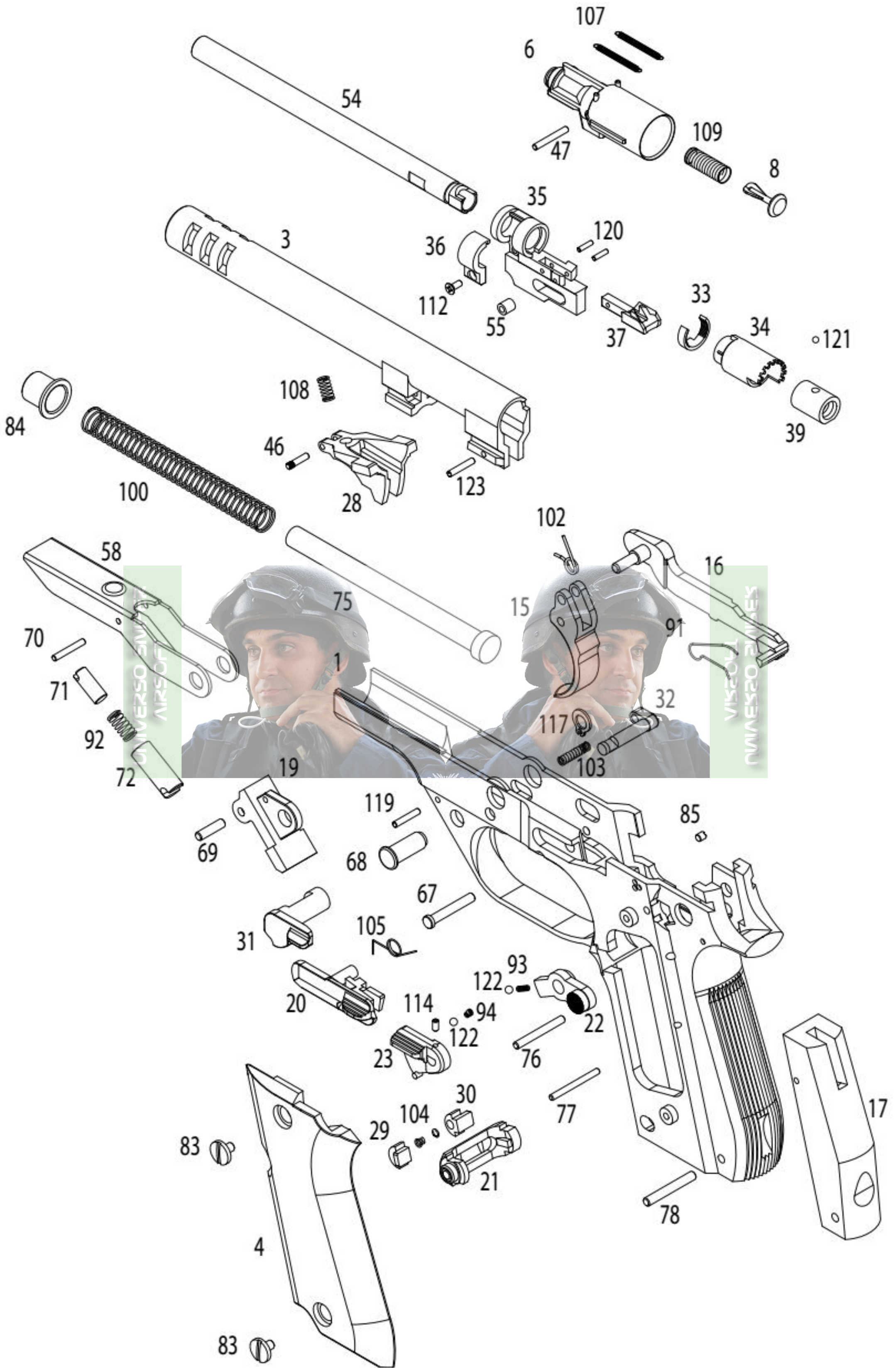

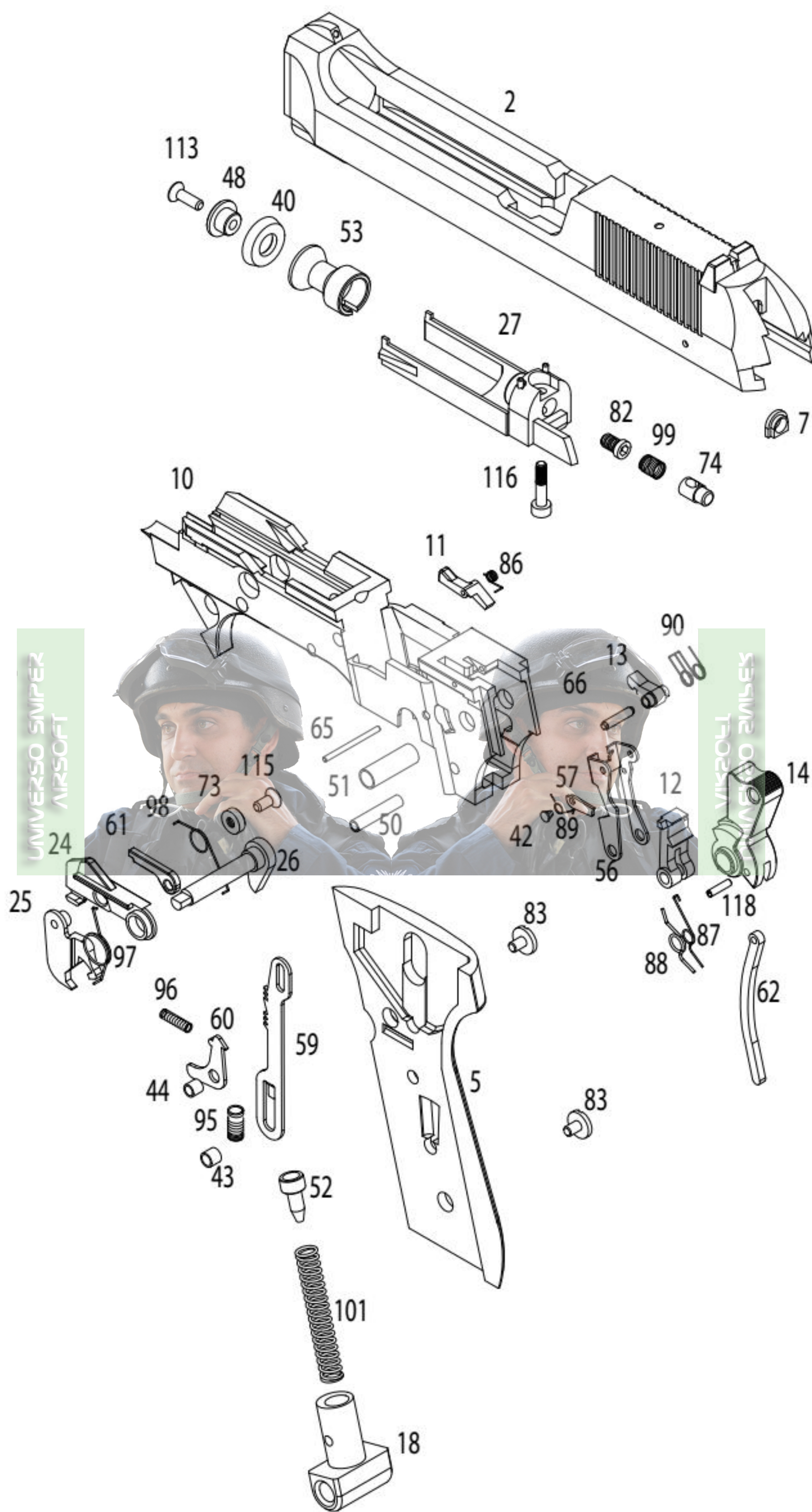

PARTS LIST

Parts #	Description
M93R-1	Frame
M93R-2	Slide
M93R-3	Outer Barrel
M93R-4	Grip (Left)
M93R-5	Grip (Right)
M93R-6	Cylinder
M93R-7	Firing Pin Sleeve
M93R-8	Jet Nozzle
M93R-10	Inner Frame Base
M93R-11	Inner Base Block
M93R-12	Sear
M93R-13	Impact Block
M93R-14	Hammer
M93R-15	Trigger
M93R-16	Trigger Bar
M93R-17	Main Spring Housing
M93R-18	Lanyard Loop Base
M93R-19	Forward Handle Base
M93R-20	Slide Catch Lever
M93R-21	Magazine Catch
M93R-22	Safety Lever
M93R-23	Selector Lever
M93R-24	Disconnecter
M93R-25	Disconnecter Locking Block
M93R-26	Disconnecter Lever Bar
M93R-27	Breech
M93R-28	Locking Block
M93R-29	Magazine Catch Spring Guide (Left)
M93R-30	Magazine Catch Spring Guide (Right)
M93R-31	Disassembly Lever
M93R-32	Disassembly Lever Pin
M93R-33	Hop Up Cylinder Clamp
M93R-34	Hop Up Cylinder
M93R-35	Inner Barrel Base
M93R-36	Inner Barrel Base Clamp
M93R-37	BB Feed Ramp
M93R-39	Hop Up Bucking
M93R-40	Main Seal
M93R-42	Impact Block Lever Pin
M93R-43	Selector Transfer Bar Bushing
M93R-44	Selector Transfer Bar Locking Hook Bushing
M93R-46	Locking Block Pin

Parts #	Description
M93R-47	Jet Nozzle Pin
M93R-48	Main Seal Cap
M93R-50	Sear Pin Sleeve
M93R-51	Hammer Pin Sleeve
M93R-52	Hammer Strut Plunger
M93R-53	Main Seal Base
M93R-54	Inner Barrel
M93R-55	Inner Barrel Base Pin Sleeve
M93R-56	Impact Block Housing
M93R-57	Impact Block Lever
M93R-58	Forward Handle
M93R-59	Selector Transfer Bar
M93R-60	Selector Transfer Bar Locking Hook
M93R-61	Selector Bar Adapter
M93R-62	Hammer Strut
M93R-65	Sear Base Assembly Pin
M93R-66	Impact Block Pin
M93R-67	Trigger Pin
M93R-68	Forward Handle Pin
M93R-69	Forward Handle Mount Pin
M93R-70	Forward Handle Spring Cover Pin
M93R-71	Forward Handle Spring Cover (Small)
M93R-72	Forward Handle Spring Cover (Large)
M93R-73	Selector Bar Bushing
M93R-74	Firing Pin
M93R-75	Recoil Spring Guide Rod
M93R-76	Sear Housing Pin
M93R-77	Top Main Spring Housing Pin
M93R-78	Main Spring Housing Pin
M93R-82	Main Seal Base Screw
M93R-83	Grips Screw
M93R-84	Recoil Spring End Cap
M93R-85	Disconnecter Pin
M93R-86	Inner Base Block Spring
M93R-87	Sear Housing Pin
M93R-88	Sear Spring
M93R-89	Impact Block Lever Spring
M93R-90	Impact Block Spring
M93R-91	Trigger Bar Spring
M93R-92	Forward Handle Spring
M93R-93	Safety Lever Spring

Parts #	Description
M93R-94	Selector Lever Spring
M93R-95	Selector Transfer Bar Spring
M93R-96	Selector Transfer Bar Locking Hook Spring
M93R-97	Disconnecter Spring
M93R-98	Selector Bar Spring
M93R-99	Firing Pin Spring
M93R-100	Recoil Spring
M93R-101	Hammer Strut Spring
M93R-102	Trigger Spring
M93R-103	Disassembly Lever Pin Spring
M93R-104	Magazine Catch Spring
M93R-105	Slide Catch Lever Spring
M93R-107	Cylinder Return Springs
M93R-108	Locking Block Spring
M93R-109	Jet Nozzle Spring
M93R-112	Inner Barrel Clamp Screw
M93R-113	Main Seal Cap Screw
M93R-114	Selector Lever Allen Screw
M93R-115	Selector Bar Bushing Screw
M93R-116	Breech Screw
M93R-117	Forward Handle Clip
M93R-118	Hammer Strut Pin
M93R-120	BB Feed Ramp Pins
M93R-121	Hop Up Bucking Ball Bearing
M93R-122	Selector Lever Ball Bearing
M93R-123	Outer Barrel Base Pin
M93R-122	Selector Lever Ball Bearing

MAGAZINE DIAGRAM AND PARTS LIST

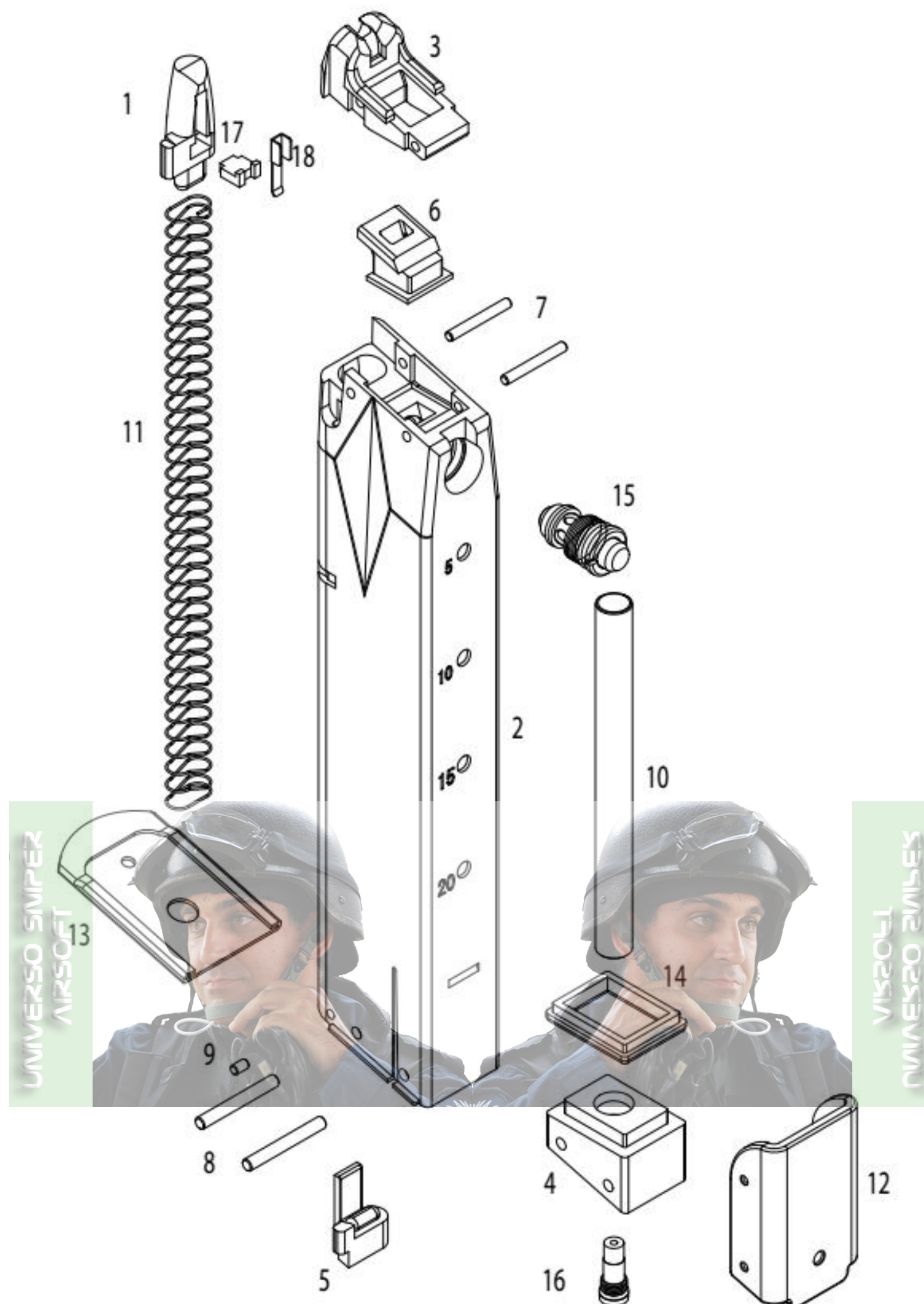

Parts #	Description
M93R-MG1	Magazine Follower
M93R-MG2	Magazine Body (Standard)
M93R-MG3	Magazine Lip
M93R-MG4	Magazine Base
M93R-MG5	Magazine Base Plate Lock
M93R-MG6	Magazine Nozzle Seal
M93R-MG7	Magazine Lip Pins
M93R-MG8	Magazine Base Lock Pins (Large)
M93R-MG9	Magazine Base Lock Pin (Small)

Parts #	Description
M93R-MG10	Magazine Expansion Tube
M93R-MG11	Magazine Follower Spring
M93R-MG12	Magazine Sleeve
M93R-MG13	Magazine Base Plate
M93R-MG14	Magazine Base Seal
M93R-MG15	Magazine Release Valve
M93R-MG16	Magazine Charging Valve
M93R-MG17	Magazine Follower Lock
M93R-MG18	Magazine Follower Leaf Spring



KWA Performance Industries, Inc.

Copyright © December, 2008 KWA Performance Industries, Inc. All Rights Reserved.