

# KWA<sup>®</sup>

## M1911A1



## OPERATOR'S MANUAL

Please read this manual carefully before using the Airsoft gun.

UNIVERSO SNIPER  
AIRSOFT



UNIVERSO SNIPER  
AIRSOFT

## TABLE OF CONTENTS

Warranty Coverage .....	3-4
Use of this manual.....	5
Safety Guidelines .....	6
Specifications .....	7
Package Contents .....	7
Charging Gas .....	8
Safety Features .....	9
Loading .....	9-10
Shooting .....	10-11
Hop-Up System .....	11-12
Disassembly .....	13-14
Assembly.....	14
General Maintenance.....	14
Basic Troubleshooting .....	15
Operating Under Unusual Conditions .....	15
Diagrams and Parts Lists:	
M1911A1 Pistol .....	16-17
M1911A1 Magazine .....	18





# KWA<sup>®</sup> WARRANTY

KWA PERFORMANCE INDUSTRIES, INC.  
18571 E. Gale Ave.,  
City of Industry, CA 91748-1339  
1-(626)-581-1777

## THANK YOU FOR PURCHASING A KWA PERFORMANCE INDUSTRIES, INC. PRODUCT.

KWA Performance Industries, Inc. is committed to serving our customers with the finest quality products, the highest level of service, and the best customer satisfaction. Because of this, we offer a 90-day warranty on all KWA products we import and distribute.

### Warranty Coverage

Except as specified below, this warranty covers all defects in material and workmanship in KWA products that occur during the above warranty period. The following are not covered by the warranty: (1) Any product which is not imported and distributed in the U.S.A. by KWA PERFORMANCE INDUSTRIES, INC. (2) Any products not purchased in the U.S.A. from a KWA AUTHORIZED RESELLER. If you are uncertain as to whether a reseller is a KWA AUTHORIZED RESELLER, please contact KWA PERFORMANCE INDUSTRIES, INC. as listed above or visit our website [www.kwausa.com/where-to-buy](http://www.kwausa.com/where-to-buy) (3) Damages, deterioration, or malfunction resulting from: a) An accident, act of nature, abuse, misuse, neglect, opening of or modification or failure to follow instructions supplied with the product. b) Repair or attempted repair by anyone not authorized by KWA PERFORMANCE INDUSTRIES, INC. c) Removal of the orange safety tip. (4) Use of the product outside the U.S.A. (5) Damaged batteries or improper use of bullets (BBs), or non approved propellants (ie. Propane, Red Gas, 134a...etc.) (6) Use in industrial, commercial, and/or professional applications.

### What KWA Will Pay For

If your KWA product is found to be defective by KWA Performance Industries, Inc. during the applicable warranty period from the date of original purchase, KWA Performance Industries, Inc. will repair, or at its option, replace with new, used, or equivalent model, the defective product without charge for parts or labor.



## How To Obtain Warranty Service

If your product needs service, it may be taken or shipped to KWA Performance Industries, Inc. The following procedures apply whenever your unit must be transported for warranty service:

- You must go to the Help Desk at [www.kwausa.com/support](http://www.kwausa.com/support) to obtain an RMA number. THE RMA NUMBER MUST BE CLEARLY MARKED ON THE OUTSIDE OF THE PACKAGE. PACKAGES WITHOUT AN RMA NUMBER CLEARLY MARKED WILL BE REFUSED AND RETURNED TO THE SENDER.
- You are responsible for transporting your unit or arranging for its transportation.
- If shipment of your unit is required; you must pay the initial shipping fee, but we will pay the return shipping charge if the repairs are covered by the warranty.
- WHEN RETURNING YOUR UNIT FOR WARRANTY SERVICE, A COPY OF THE ORIGINAL SALES RECEIPT MUST BE ATTACHED.
- You must include the following: RMA number, your name, address, daytime telephone number, model and serial number (if applicable) of the product and a description of the problem.

### **This Warranty is Only Valid in the United States**

If your product does not require service, but you have questions regarding its operation, please contact our Help Desk at [www.kwausa.com/support](http://www.kwausa.com/support).

THIS WARRANTY IS EXPRESSLY MADE IN LIEU OF ALL OTHER WARRANTIES, EXPRESSED OR IMPLIED, INCLUDING WITHOUT LIMITATION, WARRANTIES OF MERCHANTABILITY AND FITNESS FOR A PARTICULAR PURPOSE.

OUR LIABILITY IS LIMITED TO THE REPAIR OR REPLACEMENT, AT OUR OPTION, OF ANY DEFECTIVE PRODUCT AND SHALL IN NO EVENT INCLUDE INCIDENTAL OR CONSEQUENTIAL COMMERCIAL OR PROPERTY DAMAGES OF ANY KIND. WE ARE NOT RESPONSIBLE FOR PRODUCTS LOST, STOLEN AND/OR DAMAGED DURING SHIPPING.

SOME STATES DO NOT ALLOW LIMITATIONS ON HOW LONG AN IMPLIED WARRANTY LASTS AND/OR DO NOT ALLOW THE EXCLUSION OF INCIDENTAL OR CONSEQUENTIAL DAMAGES, THE ABOVE LIMITATIONS AND EXCLUSIONS MAY NOT APPLY TO YOU.

This warranty gives you specific legal rights, but you may also have other rights which vary from state to state. This Warranty may not be altered other than in writing signed by an officer of KWA Performance Industries, Inc.



## USE OF THIS MANUAL

Before operating the Airsoft gun, read this manual in its entirety. Important safety topics and tips are discussed throughout all of the chapters. It's important that the operator know the principles of gun handling, safety, and operation prior to firing the Airsoft gun.

## SAFETY GUIDELINES

### Safety Distance

The effective shooting range is approximately 50 feet. BBs fired from this Airsoft gun may travel further than intended. Make certain that you have an adequate backstop.

### Eye Protection

Eye protection should be worn at all times when both shooting and maintaining your Airsoft gun. Protect your eyes from BBs under pressure while performing maintenance on your Airsoft gun.

### Assume Every Gun is Always Loaded

Until you are certain the chamber is empty, treat every gun as if it were loaded. Do not assume the chamber is empty based on your memory or someone else's words. Always remove the magazine and visually check to confirm the chamber is empty.

### Beware of Barrel Obstructions

Ensure the Airsoft gun barrel is free of obstructions before you fire the gun. Even the smallest obstruction such as dirt, dust, or a stuck cleaning patch can cause a jam, misfire, or malfunction.

### Muzzle Control

Always keep the muzzle of the gun pointed in a safe direction. Never point the muzzle at a person or object that you do not intend to shoot.

### Keep Your Safety On

Keep the gun's safety on until your sights are aligned on your target and you are ready to fire.

### Keep Your Finger Off The Trigger

Keep your finger off the trigger and out of the trigger guard until your sights are aligned on your target and you are ready to fire.

### Identify Your Target and Backstop

Before you pull the trigger, make certain of your target and what is beyond it. The Airsoft gun should never be fired at surfaces such as rocks, glass, water, or other hard surfaces where BBs are likely to ricochet in unpredictable directions.



### WARNING:

- Airsoft BBs can be a choking hazard. Keep them away from children.
- Failure to follow safety guidelines may result in serious injury.



## SAFETY GUIDELINES (CONTINUED)

### Failure To Fire

If the Airsoft gun fails to fire, misfires, or malfunctions, do not look into the gun barrel. BBs can become lodged into the chamber, and serious eye injury may occur.

### Maintain Your Gun Properly

Performing proper maintenance, as outlined in this manual, ensures that your Airsoft gun will be safe to shoot and will perform to its designed specifications for many years. Alterations, modifications or adjustments may damage your Airsoft gun, make it unsafe to shoot, and will void all warranty claims.

### Store Your Gun Safely

Always store the Airsoft gun in a safe place, and out of reach of children. Always transport the Airsoft gun in a carrying case. Never display the Airsoft gun in a public place. Keep the safety engaged, and remove the magazine before storing the Airsoft gun.

**NOTE:** IT IS YOUR RESPONSIBILITY TO TAKE EVERY REASONABLE PRECAUTION TO ENSURE THE SAFE STORAGE AND TRANSPORTATION OF YOUR AIRSOFT GUN.

### Orange Tip

The orange tip on Airsoft guns helps Law Enforcement distinguish between the replica guns from their real firearm counterparts. Altering the coloration or markings required by state or Federal law so as to make the product look more like a firearm is dangerous and may be a crime. Operator assumes all risks and responsibility when doing so.

### Hazards of Being Mistaken for a Real Firearm

Airsoft guns have been mistaken by Police and Law Enforcement as real firearms. A confrontation with law enforcement while carrying an Airsoft gun can result in serious injury or even death. It is strongly advised to operate the Airsoft gun at a safe and legal location. In the event that you are approached by Law Enforcement personnel, you must comply with their instructions immediately to avoid an incident.

### Alcohol, Medications, and Drugs

Do not handle or operate your Airsoft gun while under the influence of alcohol, medication or drugs.

### Your Responsibility

Your Airsoft gun is well-engineered and manufactured to the highest standards. It was carefully inspected before it was packaged and shipped from our factory. Its safe use depends on you alone. You are the ultimate safety device. Like many other devices, your Airsoft gun is safe unless handled in an irresponsible or uneducated manner.



### WARNING:

- Adult supervision is required for any person under the age of 18.



## SPECIFICATIONS

- Overall Length = 209.55 mm [8.25"]
- Overall Height = 124.80 mm [4.90"]
- Inner Barrel Length = 113 mm [4.45"]
- Inner Barrel Diameter = 6.05 mm
- Weight = 0.97 kg [2.14 lbs]
- Caliber = 6 mm
- Outer Barrel Length = 127.11 mm [5.00"]
- Magazine Capacity = 21 rounds
- Velocity = 104-107 MPS [340-350 FPS]
- Energy Output with 0.20g BB = 1.07 Joules
- Gas System = NS2
- Propellant = Green Gas

### Special Features:

- Realistic construction and field stripping
- Full metal alloy construction
- Functional grip safety
- Thumb safety lever
- Adjustable hop-up
- Lanyard loop
- Rear Slide Serrations



\*Individual test results may vary depending on brand of BBs, ambient temperature, and chronograph used.

## PACKAGE CONTENTS

- 1 M1911A1 Airsoft Gun
- 1 Bottle of Silicone Oil
- 1 Magazine
- 1 Sample Bag of Airsoft BBs
- 1 Hop-Up Adjustment Tool
- 1 Operator's Manual





## CHARGING GAS

1. Release the magazine by pressing the magazine catch button.
2. Push the gas canister nozzle into the charging valve. (Make sure both the canister and magazine are inverted and in the vertical position when charging.)
3. Charge the magazine until gas overflows from the charging valve. (approximately 20 seconds.)

**Note:** It is normal to have minor leaking from the charging valve during charging due to high pressure built up inside the magazine. It is recommended to keep the gas release valve slightly oiled. Room temperature is the ideal temperature for shooting. You may experience a delayed action if the surrounding temperature drops below 68° F.

**Note:** Do not expose the magazine to direct sunlight or incinerate the magazine, as this may cause the magazine to burst. It is strongly recommended to empty the gas from the magazine after shooting. Be certain that the gas does not make contact with eyes or skin while being released, as any contact will cause cold burns.

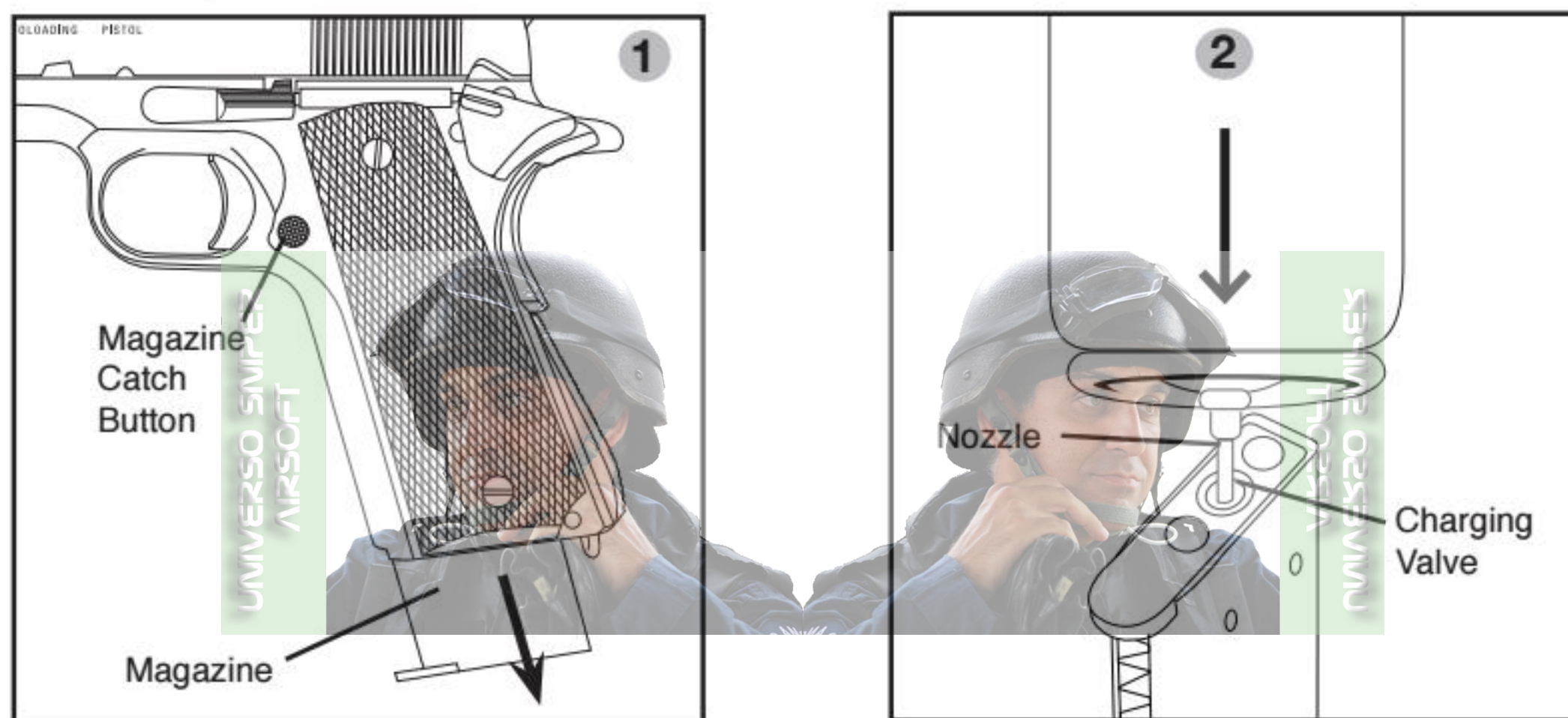

### Green Gas safety tips:

- Check the canister for any cracks or leaks before using.
- Do not expose the canister to temperature over 104° F.
- Do not leave the canister directly over fire.
- Do not heat the canister.
- Keep the canister away from direct sunlight.
- Do not leave the canister in any type of vehicle.



### WARNING:

- Avoid dropping the magazine. Sudden impact with a hard surface may cause damage to the magazine.



## SAFETY FEATURES

To engage the Safety, push the safety lever upward. The gun is not ready to fire. (UP = ON = NOT READY TO FIRE)

To disengage the Safety, push the safety lever downward. The gun is ready to fire. (DOWN = OFF = READY TO FIRE)

### GRIP SAFETY

Grip safety is on at all times. To release grip safety, hold grip firmly and grip safety will be disengaged.

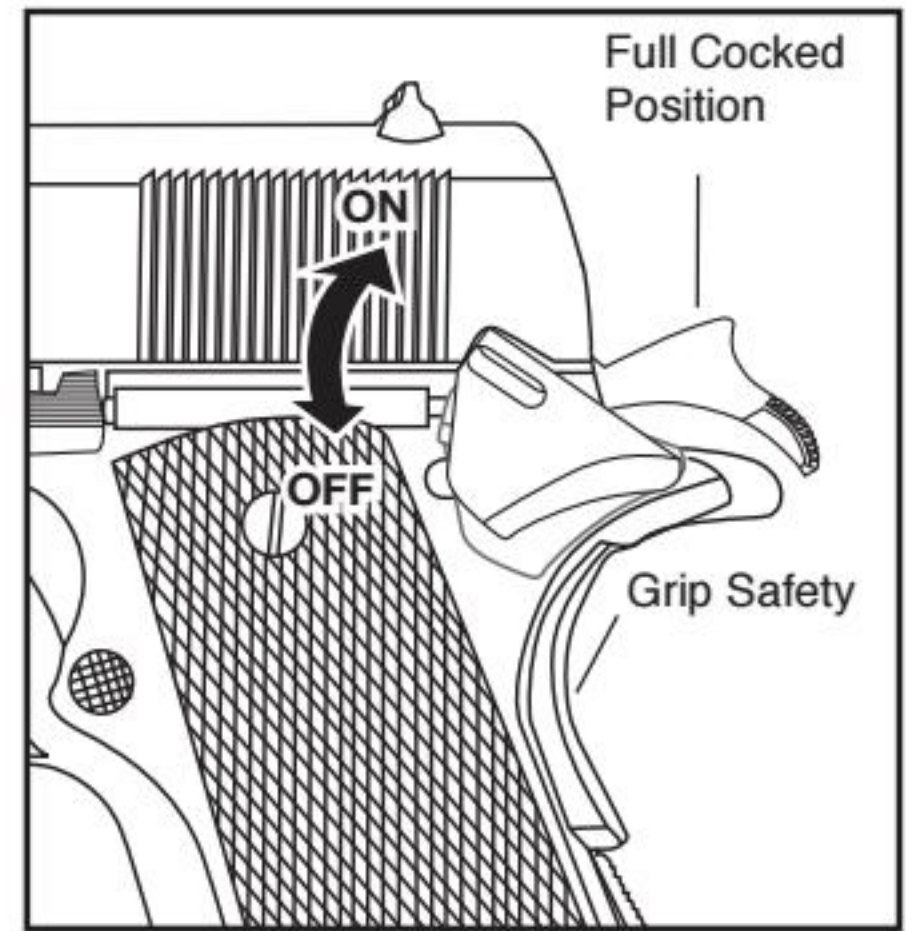

## LOADING

### LOADING BBs

1. Pull the magazine follower down until it locks.
2. Insert BBs into the magazine lip.
3. Make sure to have a 3mm clearance between BBs and the top lip of the magazine.
4. Push the magazine follower lock to release.

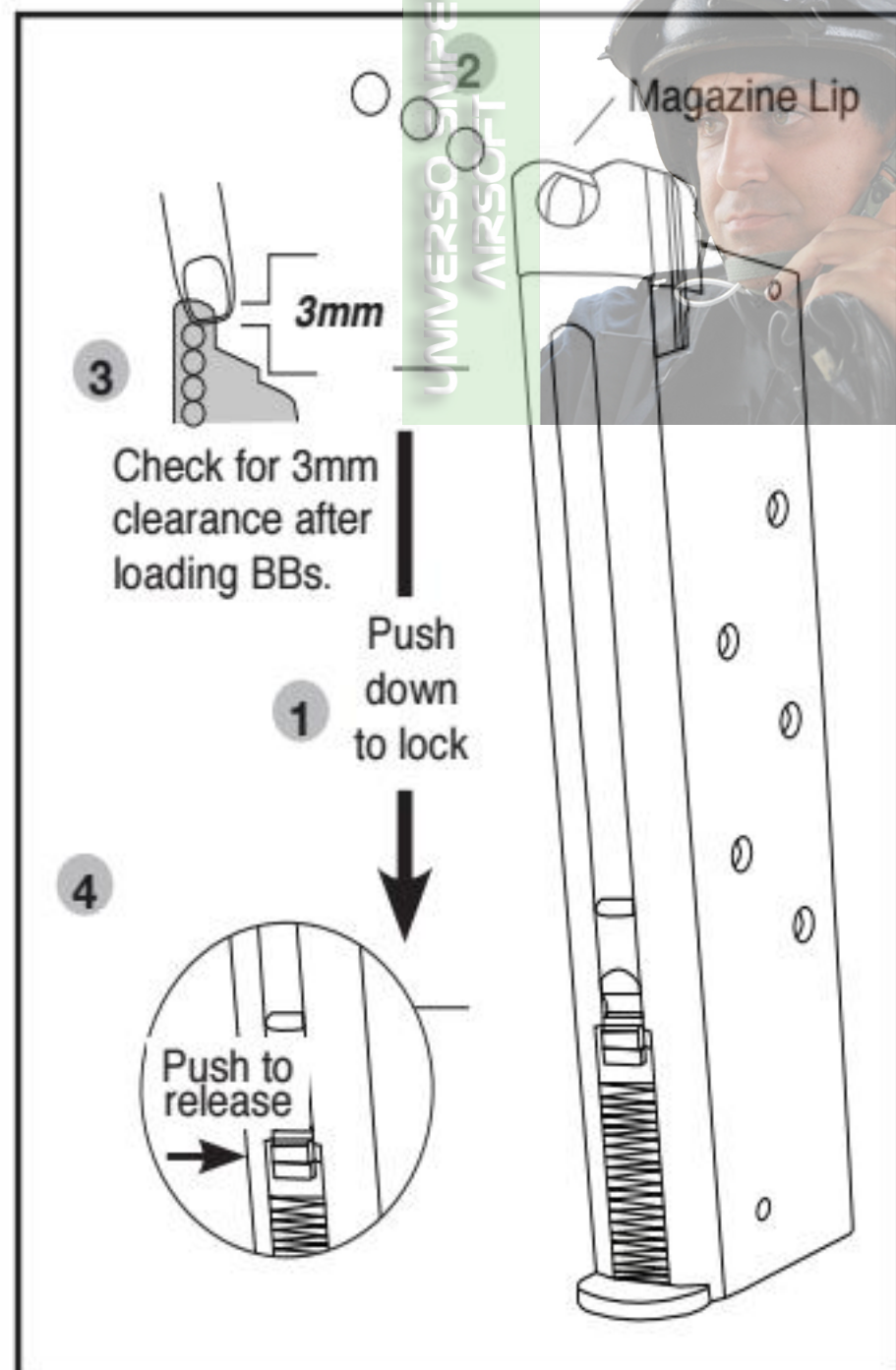

### LOADING MAGAZINE

1. Place the magazine back into the magazine well.
2. Push the magazine up until it clicks into a locked position.
3. Pull on the magazine to assure that it is locked in place.

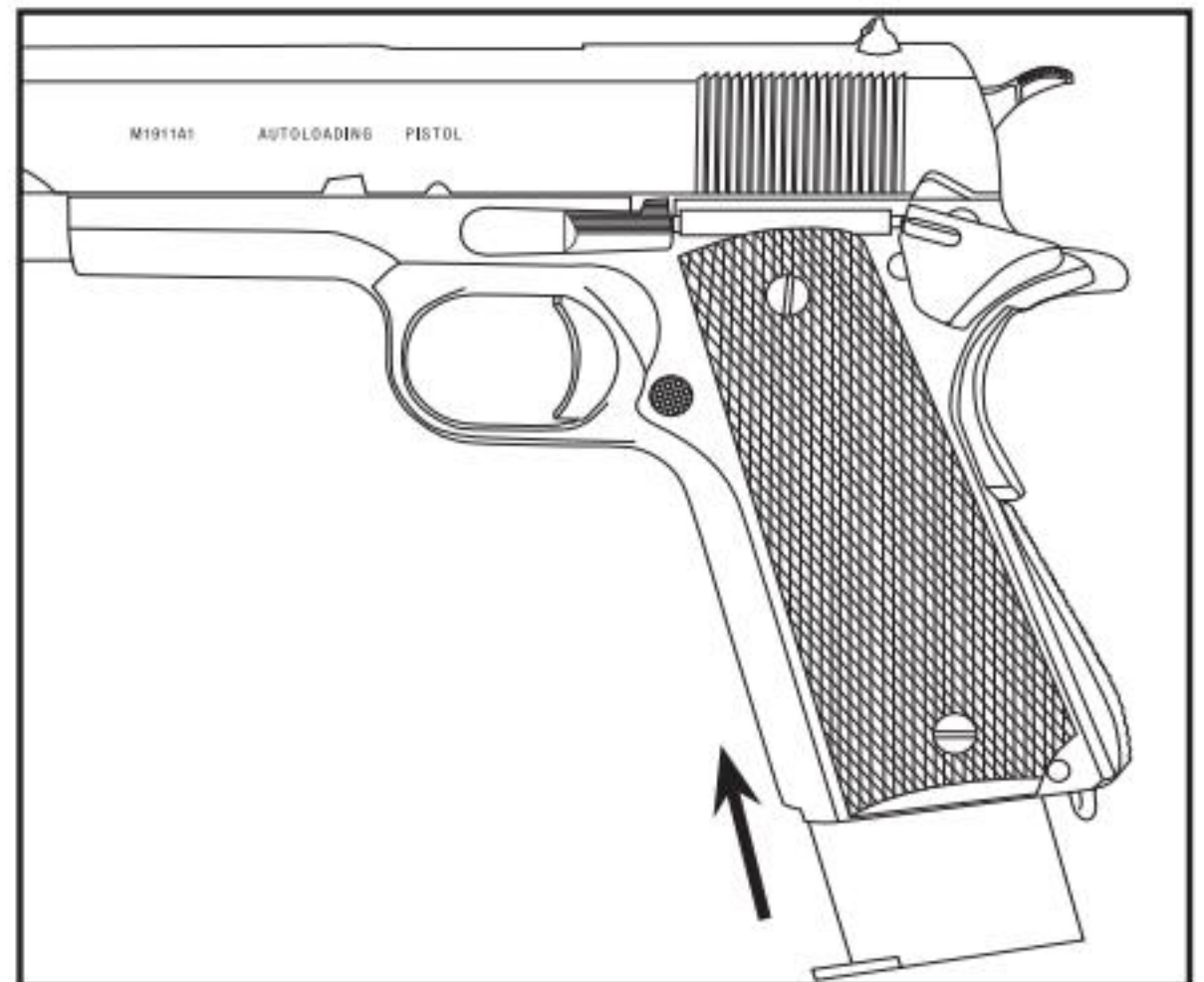

### WARNING:

- Do not release the magazine follower when the magazine is not completely filled with BB's. Doing so will damage the magazine and magazine follower.



## LOADING (CONTINUED)

### LOADING CHAMBER

Pull the slide to the rear-most position and release the slide. This will automatically load the first BB into the chamber. The hammer will be in a cocked position. Make sure not to skip this procedure. Skipping this step will cause a misfire on the first pull of the trigger. The slide will lock open when the last BB is fired.

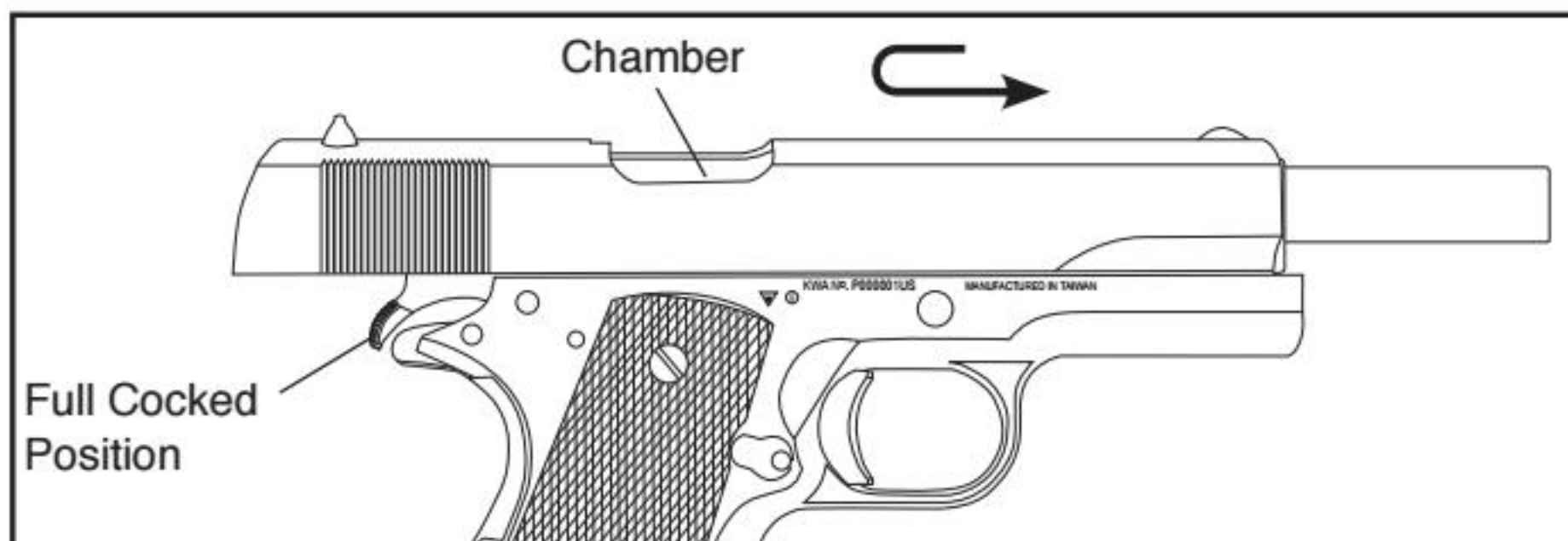

## SHOOTING

1. Make sure the gun is cocked.
2. Grasp the Airsoft gun in your hand firmly. A two-hand hold with one hand wrapped around the other will help control the Airsoft gun.
3. Release the safety and squeeze the trigger. The blow back action will load the remaining BBs automatically as the slide cycles back and forth.
4. The slide will lock back in the open position when the last BB is fired.

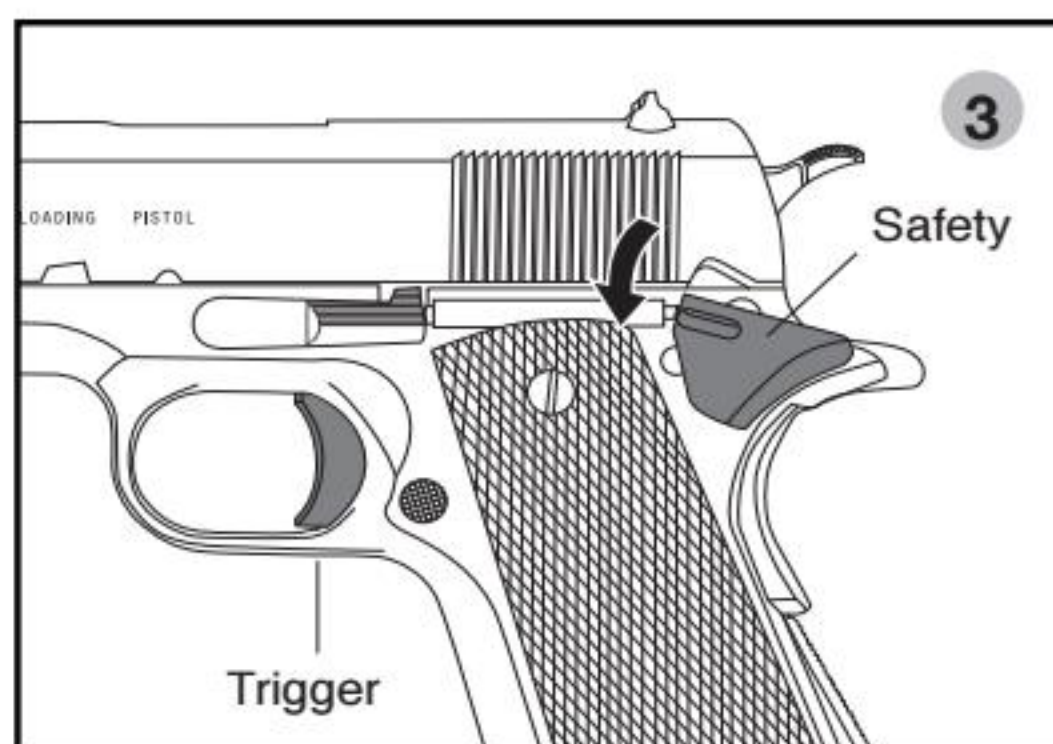
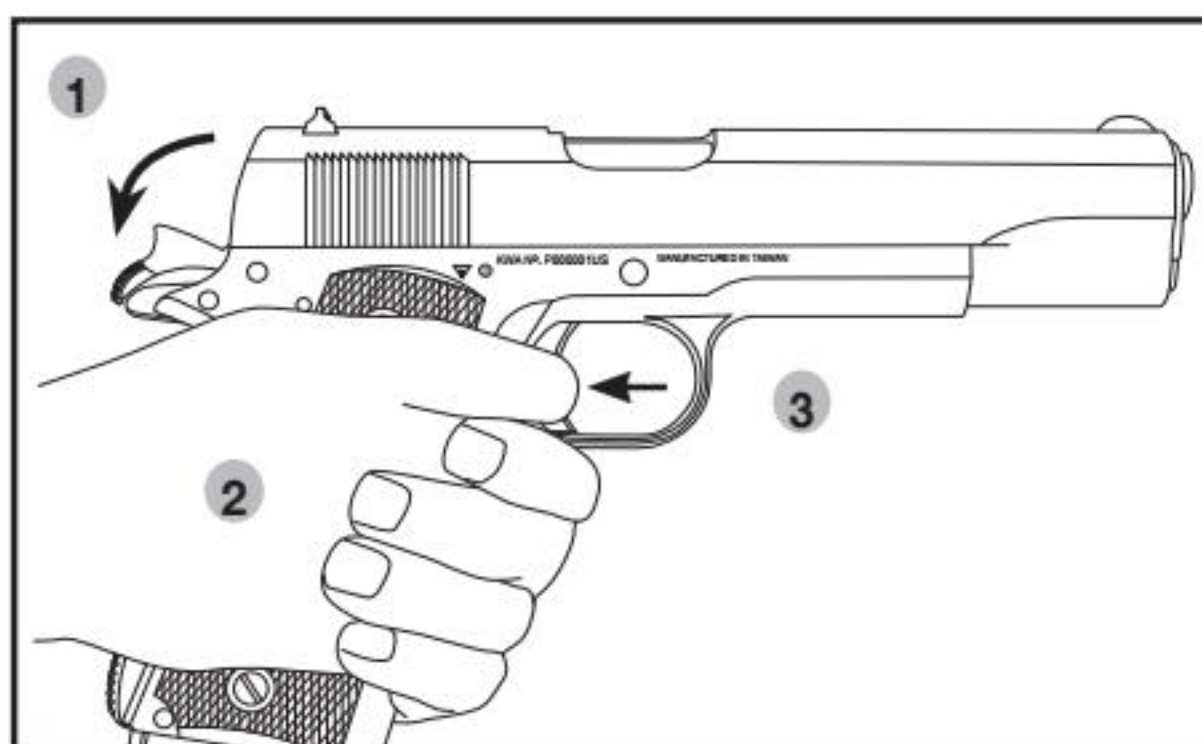

### WARNING:

- Never shoot the gun in a horizontal or upside-down position.
- Do not fire the pistol without a magazine inserted. Doing so may damage the impact block and result in the loss of the impact pin.
- Always use high quality 6mm BBs, weighing 0.2g or heavier. Using recycled or low grade BBs will damage your gun.



## SHOOTING (CONTINUED)

### OPEN SLIDE

The slide will remain open after the last BB has been fired. Remove the empty magazine and replace it with a loaded magazine before releasing the slide catch lever. The first BB will be automatically loaded into the chamber.

**Note:** It is important to treat your gun as if it were loaded even when the slide is open.

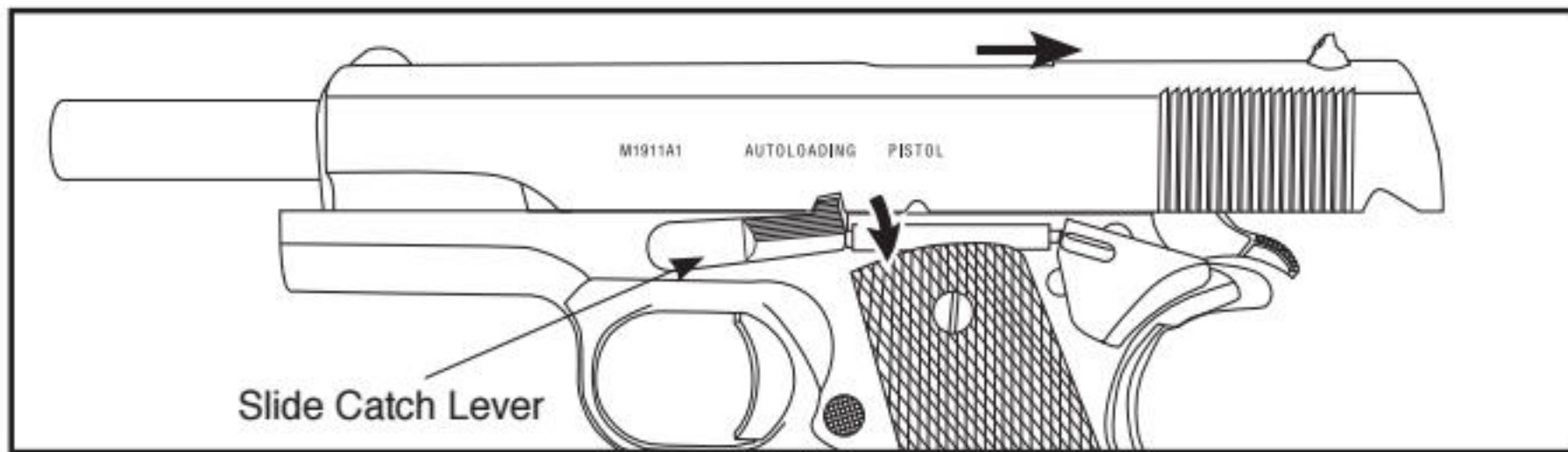

### AFTER SHOOTING

After you are finished shooting, remove the magazine and visually examine the open chamber to check for clearance. Make sure both the magazine and the chamber are clear without BBs, **release the slide then engage the safety lever.**

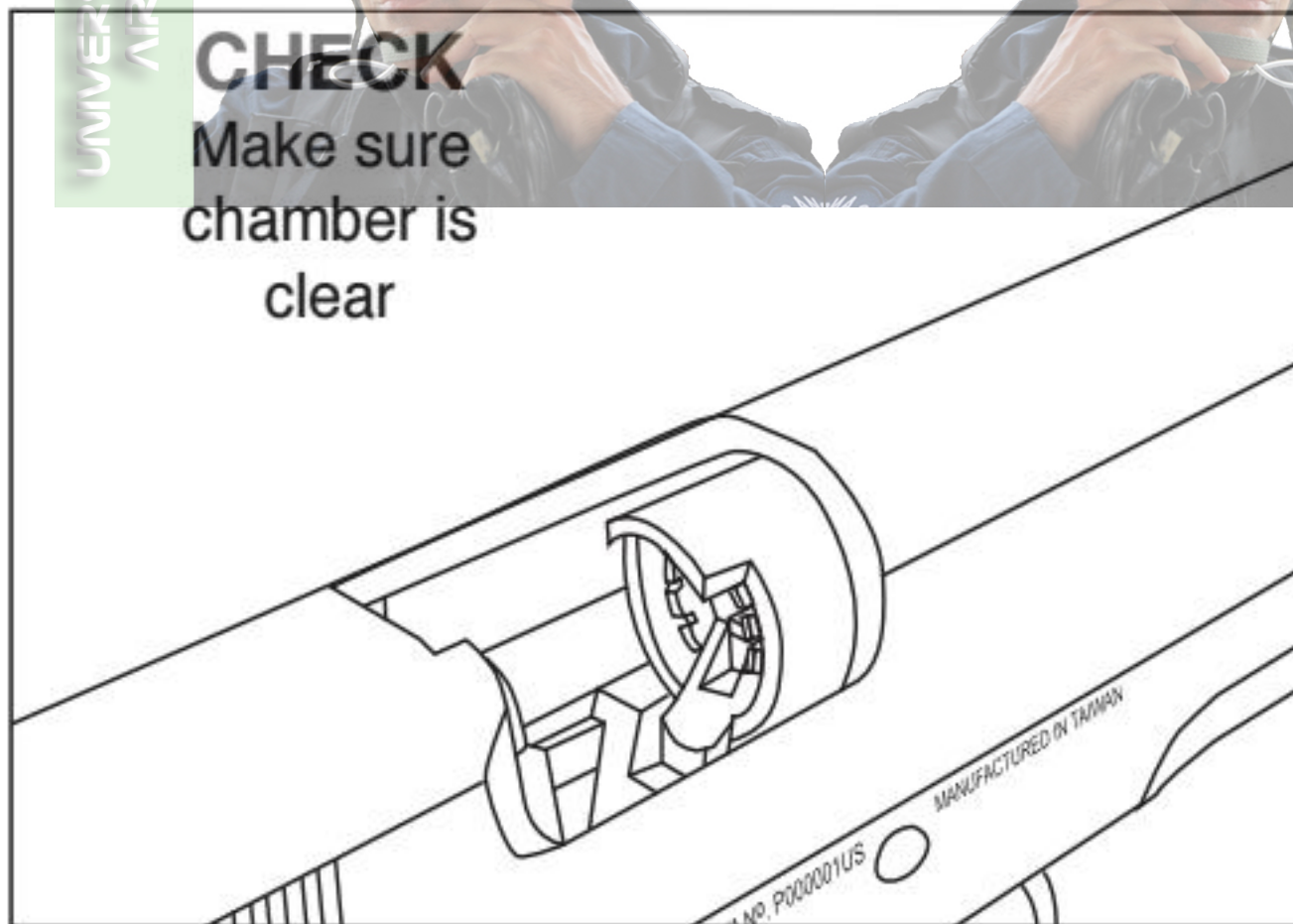

### HOP-UP SYSTEM

The Hop-Up device is one of KWA's standard features, giving Airsoft BBs greater stability, further travel and increased accuracy. Airsoft BBs are light-weight and can be affected by wind when fired. With the Hop-Up system, the trajectory of the Airsoft BBs can be adjusted according to the shooting environment or surroundings.



## HOP-UP SYSTEM (CONTINUED)











### HOP-UP ADJUSTMENT

To adjust the Hop-Up, make sure the magazine is loaded and that you have at least 65 feet of clearance for a test fire before making any adjustments.

1. Test fire the gun for 10 to 20 rounds and observe the BB's traveling pattern.
2. Remove the magazine.
3. Open the slide and place adjusting tool into the slotted chamber ring. Turn the adjusting ring a 1/4-inch at a time.
4. If the BBs are dropping too quickly, move the adjusting ring to the left or counter-clockwise to give the BB more hop. If the BBs are dropping too slowly, move the adjusting ring to the right or clock-wise.
5. Test fire and adjust as needed.



### HOP-UP ADJUSTMENT POINT

BB TRAJECTORY PATTERN		ADJUSTMENTS
	BB DROPS FREELY	 TURN KNOB TO LEFT
	BB TRAVELS AT SHORT TRAJECTORY PATH	 TURN KNOB SLIGHTLY TO LEFT
	BB TRAVELS DISTANCE AT FLAT TRAJECTORY PATH	 NO ADJUSTMENT MADE
	BB TRAVELS FLAT IN SHORT DISTANCE, THEN GOES UP IN CURVE AND DROPS FREELY	 TURN KNOB SLIGHTLY TO RIGHT
	BB TRAVELS AT UNSTABLE SPEED AND IRREGULAR PATH	 TURN KNOB TO RIGHT



## DISASSEMBLY

It is not recommended to disassemble the gun unless for general maintenance, or to clear BBs jammed inside the barrel.

1. Remove the magazine by depressing the magazine catch button on the left side of the Airsoft gun. Check and clear the chamber of BBs.
2. Pull back the slide until the small cut out slot on the slide aligns with the back end of the slide catch lever.
3. While holding the slide in position, remove the slide catch lever by pushing the pin on the right side of frame. Pull off the slide catch lever from the left side of the frame.
4. Glide the slide forward, away from the frame.
5. Remove the recoil spring and guide rod.
6. Remove the recoil plug from the slide.
7. Turn the barrel bushing counter-clockwise and pull it off of the barrel tip.
8. Slide the barrel unit out through the front opening of the slide.

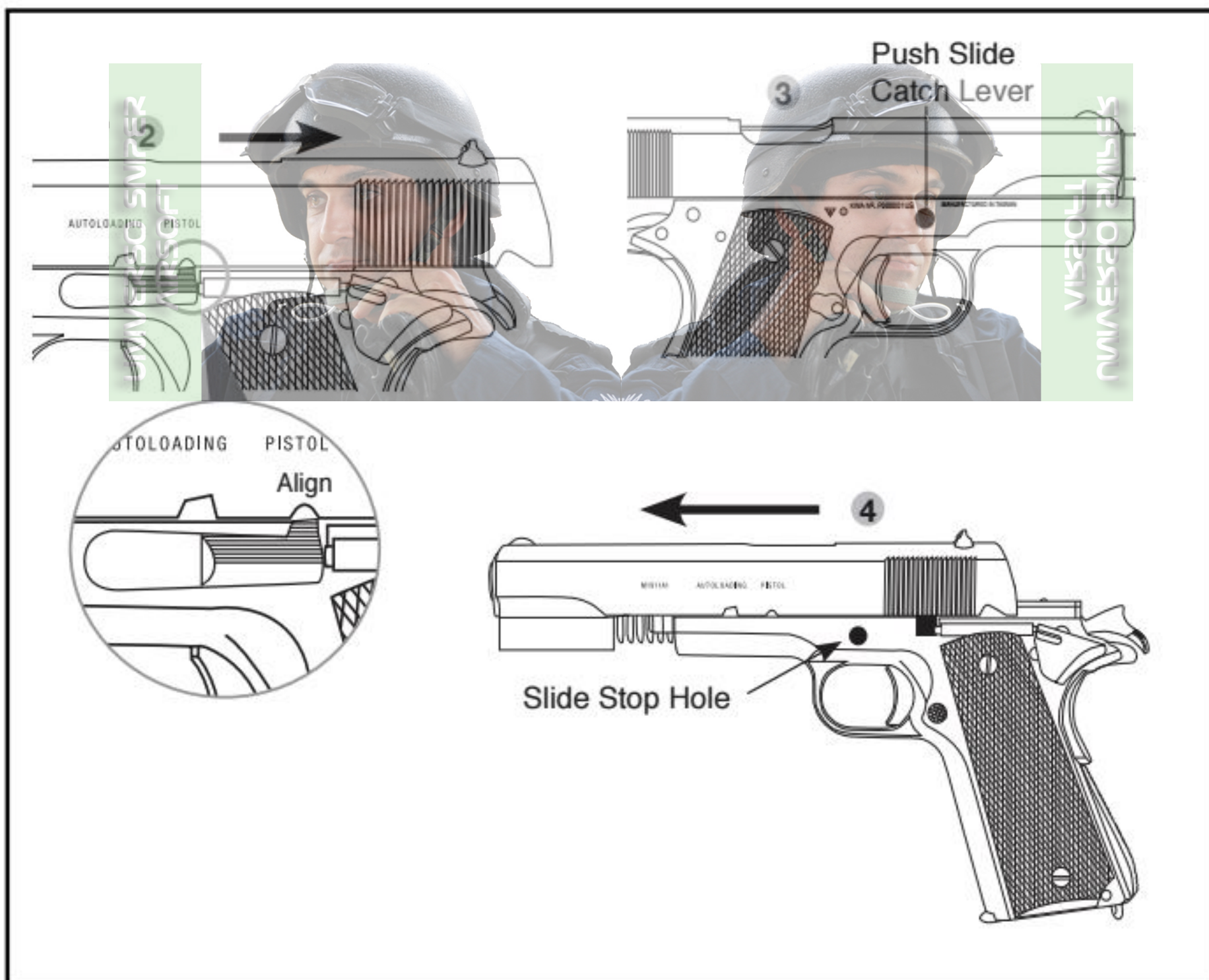



## DISASSEMBLY (CONTINUED)

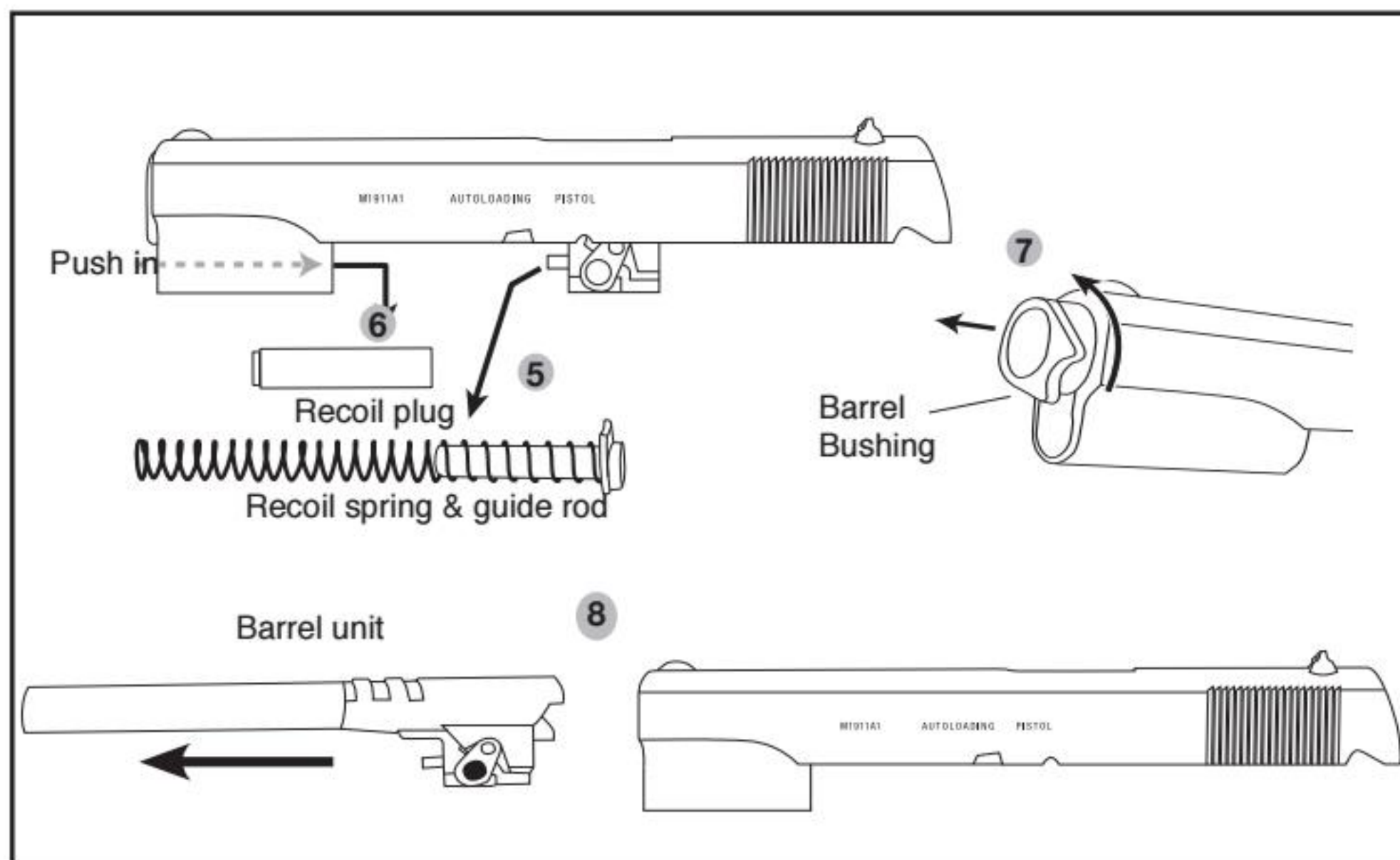

## ASSEMBLY

1. Place the barrel unit into the slide and re-attach the barrel bushing to the barrel tip.
2. Insert the recoil spring and guide rod into the slide.
3. Install the recoil plug into position.
4. Put the assembled slide onto the frame rails and glide it toward the rear of the gun.
5. Align the Barrel Link Hole with the Slide Catch Hole and re-insert the slide catch lever through the slide and push the lever back into position.
6. Push the slide toward the rear, cycle the slide back and forth to insure proper assembly.

## GENERAL MAINTENANCE FOR KWA GAS BLOW BACK

Green gas is a liquid propellant which tends to dry out the seals and o-rings. With lubricating silicone oil, it will extend the life of the seals and o-rings and prevent gas leaks.

Use only the recommended 100% silicone oil, available for purchase at the Airsoft dealer where you purchased your KWA products. Any other type of lubricant may damage the products.

Lightly lubricate the recoil spring, cylinder and moving parts with a few drops of oil. Lubricating the seals and o-rings are essential. Unload BBs from the magazine. Make sure the magazine is free of gas before lubricating the magazine's charging valve and release valve.



BASIC TROUBLESHOOTING GUIDE FOR PISTOL		
SYMPTOMS	POSSIBLE CAUSE	SOLUTIONS
Slide jams / Will not complete cycle	Dry internals	Add silicone to cylinder / main seal
Double feeds BBs into Chamber / BB's roll out of barrel	Hop-up adjustment too tight	Release hop-up or replace bucking
BBs will not release from magazine / bent mag lip/ check BB condition	Bent magazine lip	Replace magazine lip
Leaking release valve & charging valve	Dry O-ring	Add silicone oil to valves / Replace valves
Slide stop engages while shooting BBs	Weak slide stop spring	Adjust tension
Magazine base plate will not lock	Broken base plate lock	Replace base plate lock
Magazine base leaking air	Worn out base seal	Replace magazine base seal
Cylinder will not load BBs into chamber	Broken cylinder tab	Replace cylinder
Trigger will not reset	Worn out trigger spring / trigger bow spring	Replace trigger spring / trigger bow spring

## OPERATING UNDER UNUSUAL CONDITIONS

Unusual conditions are defined as any condition requiring special maintenance. Perform maintenance outlined for the climate similar to your operational area.

### Extreme Cold:

Operating an Airsoft gas gun in extremely cold temperatures is not recommended. Cold temperatures will cause the Hop-up Bucking to harden, reducing its effectiveness. Gas will not expand properly in cold temperatures, so both the cycling rate and power will be dramatically reduced.

### Extreme Heat:

Operating an Airsoft gas gun in extremely hot temperatures is also not recommended. Leaving the gun in direct sunlight for long periods of time, or operating in extremely hot areas will cause the gas to over-expand, damaging the internal workings of the gun. The increase in internal pressure from the expanding gas can also damage the seals and cause leaks in the magazine.

### Dust or Sand:

Dust or sand can get into a gas gun and cause malfunctions and/or excessive wear. Keep the gun covered whenever possible. Use lubricant sparingly, as lube naturally attracts dirt and other particles. After use in a dusty area, always field strip the gun (refer to Disassembly Section) and clean any areas you can reach with a soft, lint-free cloth.







## M1911A1 PARTS LIST

Parts #	Description	Parts #	Description	Parts #	Description	Parts #	Description
M1911A1-7	CYLINDER	M1911A1-48	MAIN SEAL CAP	M1911A1-73	FIRING PIN SPRING	M1911A1-334	SLIDE
M1911A1-8	JET NOZZLE	M1911A1-49	CYLINDER PIN	M1911A1-74	PLUNGER SPRING	M1911A1-335	OUTER BARREL
M1911A1-9	HOP-UP CYLINDER CLAMP	M1911A1-50	BARREL LINK PIN	M1911A1-75	IMPACT HAMMER SPRING	M1911A1-336	SLIDE CATCH LEVER
M1911A1-10	HOP-UP CYLINDER	M1911A1-51	MAIN SEAL BASE SCREW	M1911A1-76	IMPACT HAMMER LOCK SPRING	M1911A1-337	HAMMER
M1911A1-15	BARREL BUSHING	M1911A1-52	FIRING PIN	M1911A1-77	MAIN SPRING	M1911A1-338	TRIGGER
M1911A1-16	PLUNGER TUBE	M1911A1-53	INNER BARREL	M1911A1-78	SEAR SPRING	M1911A1-339	SAFETY LEVER
M1911A1-19	INNER FRAME	M1911A1-54	BB FEED RAMP PIN	M1911A1-81	TRIGGER BOW	M1911A1-340	MAIN SPRING HOUSING
M1911A1-27	BREECH BLOCK	M1911A1-55	RECOIL SPRING GUIDE CAP	M1911A1-82	HAMMER STRUT	M1911A1-341	MAGAZINE CATCH LOCK
M1911A1-28	INNER BARREL BASE	M1911A1-56	TRIGGER BOW SET PIN	M1911A1-85	RECOIL BUFFER	M1911A1-342	REAR SIGHT
M1911A1-29	INNER BARREL LOCK	M1911A1-57	SLIDE RELEASE LEVER	M1911A1-86	MAIN SEAL	M1911A1-343	RECOIL PLUG
M1911A1-30	BARREL LINK	M1911A1-58	SAFETY LEVER PLUNGER	M1911A1-87	HOP-UP BUCKING	M1911A1-344	MAGAZINE CATCH
M1911A1-31	BB FEED RAMP	M1911A1-59	IMPACT HAMMER PIN	M1911A1-90	INNER BARREL LOCK SCREW	M1911A1-345	GRIP SAFETY
M1911A1-32	SEAR	M1911A1-60	IMPACT PIN	M1911A1-91	MAIN SEAL CAP SCREW	M1911A1-347	SLIDE RELEASE CAP
M1911A1-33	DISCONNECTOR	M1911A1-61	SLIDE RELEASE SLEEVE	M1911A1-93	INNER FRAME SCREW	M1911A1-348	GRIP SCREWS X 4
M1911A1-34	IMPACT FRAME	M1911A1-63	MAIN SPRING HOUSING PIN	M1911A1-95	STOPPER SCREW	M1911A1-350	REAR SIGHT SCREW
M1911A1-35	IMPACT HAMMER	M1911A1-64	MAIN SPRING RETAINER PIN	M1911A1-97	ROLL PINS	M1911A1-351	BREECH SCREW
M1911A1-36	IMPACT HAMMER LOCK	M1911A1-65	MAIN SPRING RETAINER	M1911A1-98	HAMMER STRUT PIN		
M1911A1-37	STOPPER	M1911A1-66	MAIN SPRING CATCH	M1911A1-99	HOP-UP BALL		
M1911A1-38	GRIP WEIGHT (LEFT)	M1911A1-69	MAGAZINE CATCH SPRING	M1911A1-105	SPRING GUIDE SPACER		
M1911A1-39	GRIP WEIGHT (RIGHT)	M1911A1-70	RECOIL SPRING	M1911A1-180	HAMMER PIN		
M1911A1-42	RECOIL SPRING GUIDE	M1911A1-71	JET NOZZLE SPRING	M1911A1-330	GRIP (LEFT)		
M1911A1-43	SEAR PIN	M1911A1-72	CYLINDER SPRINGS X 2	M1911A1-331	GRIP (RIGHT)		
M1911A1-44	SEAR SLEEVE			M1911A1-333	FRAME		
M1911A1-47	MAIN SEAL BASE						



# M1911A1 MAGAZINE DIAGRAM AND PARTS LIST

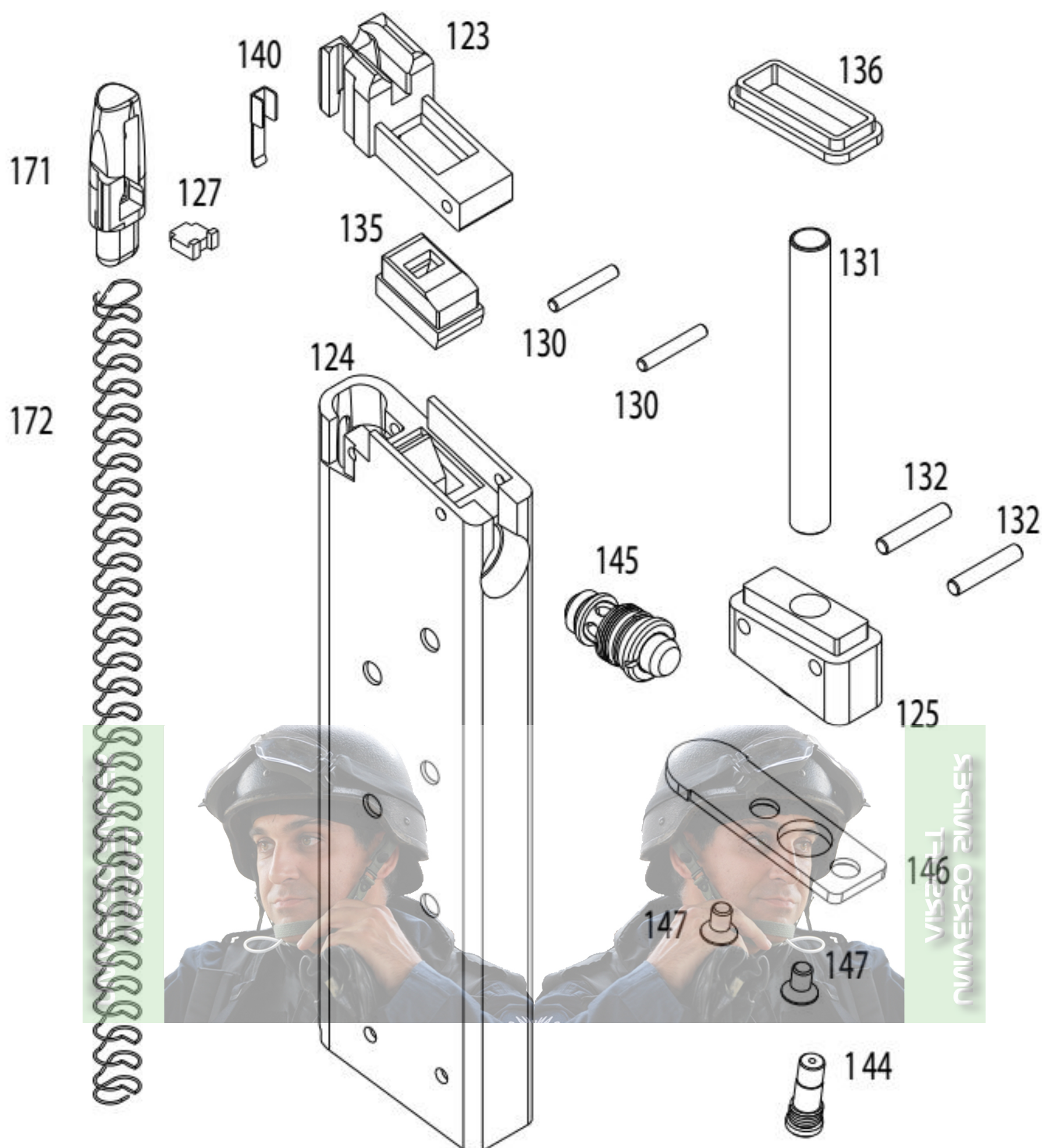

Parts #	Description
M1911A1-123	MAGAZINE LIP
M1911A1-124	MAGAZINE CASE
M1911A1-125	MAGAZINE BASE
M1911A1-127	MAGAZINE FOLLOWER LOCK
M1911A1-130	MAGAZINE LIP PINS X 2
M1911A1-131	MAGAZINE EXPANSION TUBE
M1911A1-132	MAGAZINE BASE PINS X 2
M1911A1-135	MAGAZINE NOZZLE SEAL
M1911A1-136	MAGAZINE SEAL

Parts #	Description
M1911A1-140	MAGAZINE FOLLOWER LOCK SPRING
M1911A1-144	MAGAZINE CHARGING VALVE
M1911A1-145	MAGAZINE RELEASE VALVE
M1911A1-146	MAGAZINE BASE PLATE
M1911A1-147	MAGAZINE BASE PLATE SCREWS X 2
M1911A1-171	MAGAZINE FOLLOWER
M1911A1-172	MAGAZINE FOLLOWER SPRING





**KWA Performance Industries, Inc.**

18571 E. Gale Ave  
City of Industry, CA 91748  
T: 1.626.581.1777 • F: 1.626.581.0777  
[WWW.KWAUSA.COM](http://WWW.KWAUSA.COM)