

KWA®

OPERATOR'S MANUAL



UNIVERSO SNIPER
ARSOFT

UNIVERSO SNIPER
ARSOFT

1911 MARK PTP SERIES

TABLE OF CONTENTS

Use of this manual.....	2
Safety Guidelines	2-3
Specifications & Package Contents	4-7
Functions and Features	8
Charging Gas	9
Loading BBs	10
Loading Magazine	11
Safety	11
Loading Chamber	11
Shooting	12
Open Slide	13
After Shooting	13
Hop-Up System	14
Hop-Up Adjustment Point	15
Disassembly	16
Assembly	16
Troubleshooting	17
General Maintenance	18
Operating Under Unusual Conditions.....	18
Diagrams and Parts Lists	19-31

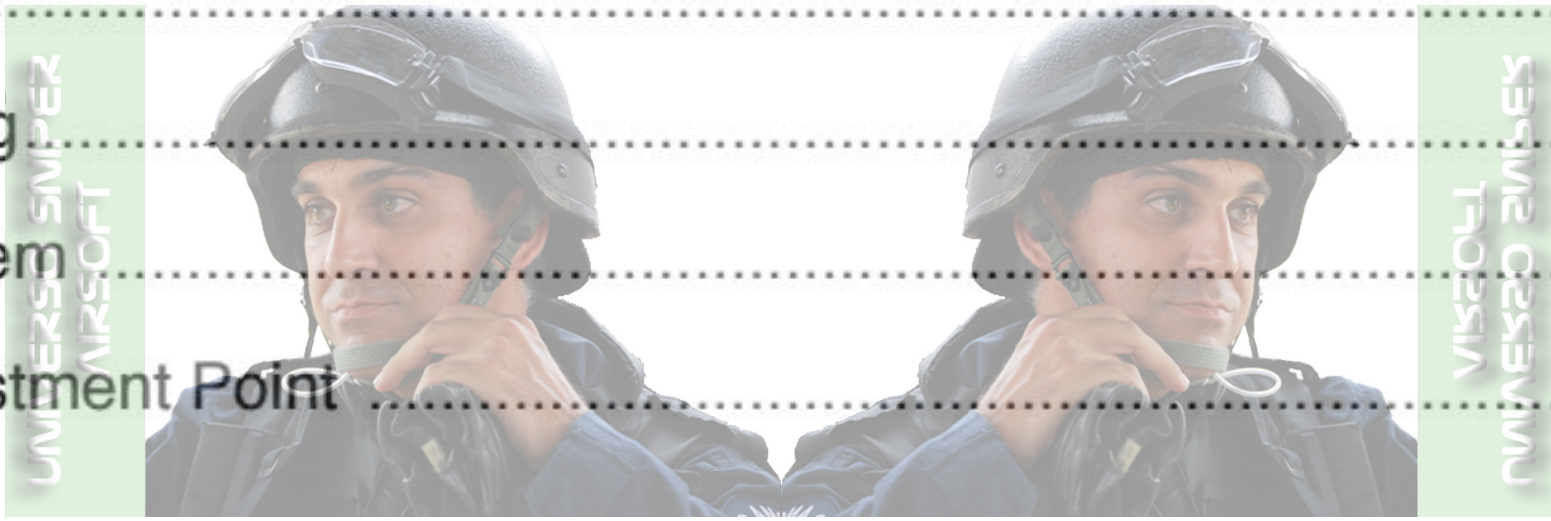

USE OF THIS MANUAL

Before operating the Airsoft gun, read this manual in its entirety. Important safety topics and tips are discussed throughout all of the chapters. It's important that the operator know the principles of gun handling safety and operation prior to firing the Airsoft gun.

SAFETY GUIDELINES



WARNING! Failure to follow safety guidelines may result in serious injury.

Safety Distance

The effective shooting range is approximately 75 feet. BBs fired from this Airsoft gun may travel further than intended. Make certain that you have an adequate backstop.

Eye Protection

Eye protection should be worn at all times when both shooting and maintaining your Airsoft gun. Protect your eyes from BBs under pressure while performing maintenance on your Airsoft gun.

Assume Every Gun is Always Loaded

Until you are certain the chamber is empty, treat every gun as if it were loaded. Do not assume the chamber is empty based on your memory or someone else's words. Always remove the magazine and visually check to confirm the chamber is empty.

Beware of Barrel Obstructions

Ensure the Airsoft gun barrel is free of obstructions before you fire the gun. Even the smallest obstruction such as lubrication or a stuck cleaning patch can cause a misfire or malfunction.

Muzzle Control

Always keep the muzzle of the gun pointed in a safe direction. Never point the muzzle at a person or object that you do not intend to shoot.

Keep Your Safety On

Keep the gun's safety on until your sights are aligned on your target and you are ready to fire.

Keep Your Finger Off The Trigger

Keep your finger off the trigger and out of the trigger guard until your sights are aligned on your target and you are ready to fire.



WARNING! Airsoft BBs can be a choking hazard. Keep them away from children.

SAFETY GUIDELINES

Identify Your Target and Backstop

Before you pull the trigger, make certain of your target and what is beyond it. The Airsoft gun should never be fired at surfaces such as rocks, glass, water, or other hard surfaces where BBs are likely to ricochet in unpredictable directions.



WARNING! Adult supervision is required for any person under the age of 18.

Failure To Fire

If the Airsoft gun fails to fire, misfires, or malfunctions, do not look into the gun barrel. BBs can become lodged into the chamber, and serious eye injury may occur.

Maintain Your Gun Properly

Performing proper maintenance, as outlined in this manual, ensures that your Airsoft gun will be safe to shoot and will perform to its designed specifications for many years. Alterations, modifications or adjustments may damage your Airsoft gun, make it unsafe to shoot, and will void all warranty claims.

Store Your Gun Safely

Always store the Airsoft gun in a safe place, and out of the reach of children. Always transport the Airsoft gun in a carrying case. Never display the Airsoft gun in a public place. Keep the safety engaged, and remove the magazine before storing the Airsoft gun. Note: it is your responsibility to take every reasonable precaution to ensure the safe storage and transportation of your Airsoft gun.

Orange Tip

The orange tip on Airsoft guns helps Law Enforcement distinguish between the replica guns from their real firearm counterparts. Altering the coloration or markings required by state or Federal law so as to make the product look more like a firearm is dangerous and may be a crime. Operator assumes all risks and responsibility when doing so.

Hazards of Being Mistaken for a Real Firearm

Airsoft guns have been mistaken by Police and Law Enforcement as real firearms. A confrontation with law enforcement while carrying an Airsoft gun can result in serious injury or even death. It is strongly advised to operate the Airsoft gun at a safe and legal location. In the event that you are approached by Law Enforcement personnel, you must comply with their instructions immediately to avoid an incident.

Alcohol, Medications, and Drugs

Do not handle or operate your Airsoft gun while under the influence of alcohol, medication or drugs.

Your Responsibility

Your Airsoft gun is well-engineered and manufactured to the highest standards. It was carefully inspected before it was packaged and shipped from our factory. Its safe use depends on you alone. You are the ultimate safety device. Like many other devices, your Airsoft gun is safe unless handled in an irresponsible or uneducated manner.

SPECIFICATIONS

1911 MARK I

- Overall Length = 22.22 cm [8.75"]
- Overall Height = 15.24 cm [6"]
- Inner Barrel Length = 115 mm
- Inner Barrel Diameter = 6.05 mm
- Weight = 1.01 kg [2.23 lbs]
- Caliber = 6 mm
- Magazine Capacity = 14 rounds
- Velocity = 104-107 MPS [340-350 FPS]
- Energy Output with 0.20g BB = 1.07 Joules
- Gas System = NS2
- Propellant = Green Gas

Special Features:

- Realistic construction and field stripping
- Functional beavertail grip safety
- Thumb safety lever
- Skeletonized hammer and trigger
- Front and rear slide serrations
- Full metal alloy construction
- Combat sight
- Adjustable hop-up



*Individual test results may vary depending on brand of BBs, ambient temperature, and chronograph used.

PACKAGE CONTENTS

- 1 1911 Mark I PTP
- 1 Bottle of Silicone Oil
- 1 Magazine
- 1 Sample bag of Airsoft BBs
- 1 Hop-Up Adjustment Tool
- 1 Operator's Manual



SPECIFICATIONS

1911 MARK II

- Overall Length = 22.22 cm [8.75"]
- Overall Height = 15.24 cm [6"]
- Inner Barrel Length = 115 mm
- Inner Barrel Diameter = 6.05 mm
- Weight = 1.09 kg [2.4 lbs]
- Caliber = 6 mm
- Magazine Capacity = 14 rounds
- Velocity = 104-107 MPS [340-350 FPS]
- Energy Output with 0.20g BB = 1.07 Joules
- Gas System = NS2
- Propellant = Green Gas

Special Features:

- Realistic construction and field stripping
- Functional beavertail grip safety
- Thumb safety lever
- Skeletonized hammer and trigger
- Front and rear slide serrations
- Accessory rail
- Full metal alloy construction
- Combat sight
- Adjustable hop-up



*Individual test results may vary depending on brand of BBs, ambient temperature, and chronograph used.

PACKAGE CONTENTS

- 1 1911 Mark II PTP
- 1 Bottle of Silicone Oil
- 1 Magazine
- 1 Sample bag of Airsoft BBs
- 1 Hop-Up Adjustment Tool
- 1 Operator's Manual

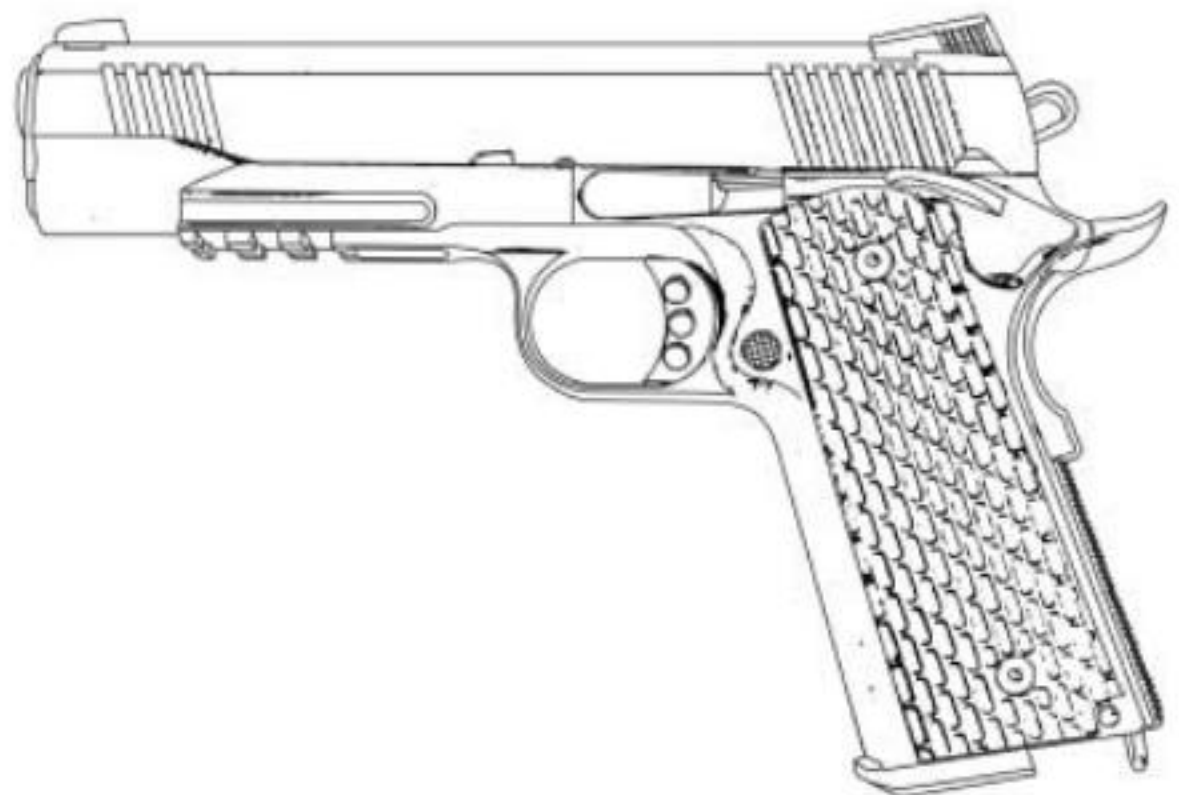

SPECIFICATIONS

1911 MARK III

- Overall Length = 22.22 cm [8.75"]
- Overall Height = 15.24 cm [6"]
- Inner Barrel Length = 115 mm
- Inner Barrel Diameter = 6.05 mm
- Weight = 1.01 kg [2.23 lbs]
- Caliber = 6 mm
- Magazine Capacity = 14 rounds
- Velocity = 104-107 MPS [340-350 FPS]
- Energy Output with 0.20g BB = 1.07 Joules
- Gas System = NS2
- Propellant = Green Gas

Special Features:

- Realistic construction and field stripping
- Functional beavertail grip safety
- Thumb safety lever
- Skeletonized hammer and trigger
- Front and rear slide serrations
- Full metal alloy construction
- Combat sight
- Conical outer barrel
- Adjustable hop-up



*Individual test results may vary depending on brand of BBs, ambient temperature, and chronograph used.

PACKAGE CONTENTS

- 1 1911 Mark III PTP
- 1 Bottle of Silicone Oil
- 1 Magazine
- 1 Sample bag of Airsoft BBs
- 1 Hop-Up Adjustment Tool
- 1 Operator's Manual



SPECIFICATIONS

1911 MARK IV

- Overall Length = 22.22 cm [8.75"]
- Overall Height = 15.24 cm [6"]
- Inner Barrel Length = 115 mm
- Inner Barrel Diameter = 6.05 mm
- Weight = 1.09 kg [2.4 lbs]
- Caliber = 6 mm
- Magazine Capacity = 14 rounds
- Velocity = 104-107 MPS [340-350 FPS]
- Energy Output with 0.20g BB = 1.07 Joules
- Gas System = NS2
- Propellant = Green Gas

Special Features:

- Realistic construction and field stripping
- Functional beavertail grip safety
- Thumb safety lever
- Skeletonized hammer and trigger
- Front and rear slide serrations
- Accessory rail
- Full metal alloy construction
- Combat sight
- Conical outer barrel
- Adjustable hop-up



*Individual test results may vary depending on brand of BBs, ambient temperature, and chronograph used.

PACKAGE CONTENTS

- 1 1911 Mark VI PTP
- 1 Bottle of Silicone Oil
- 1 Magazine
- 1 Sample bag of Airsoft BBs
- 1 Hop-Up Adjustment Tool
- 1 Operator's Manual



CHARGING GAS

1. Release the magazine by pressing the magazine catch button.
2. Push the gas canister nozzle into the charging valve. (Make sure both the canister and magazine are inverted and in the vertical position when charging.)
3. Charge the magazine until gas overflows from the charging valve.



WARNING: Avoid dropping the magazine. Sudden impact with a hard surface may cause damage to the magazine.

Note: It is normal to have minor leaking from the charging valve during charging due to high pressure built up inside the magazine. It is recommended to keep the gas release valve slightly oiled. Room temperature is the ideal temperature for shooting. You may experience a delayed action if the surrounding temperature drops below 68° F.

Note: Do not expose the magazine to direct sunlight or incinerate the magazine, as this may cause the magazine to burst. It is strongly recommended to empty the gas from the magazine after shooting. Be certain that the gas does not make contact with eyes or skin while being released, as any contact will cause cold burns.

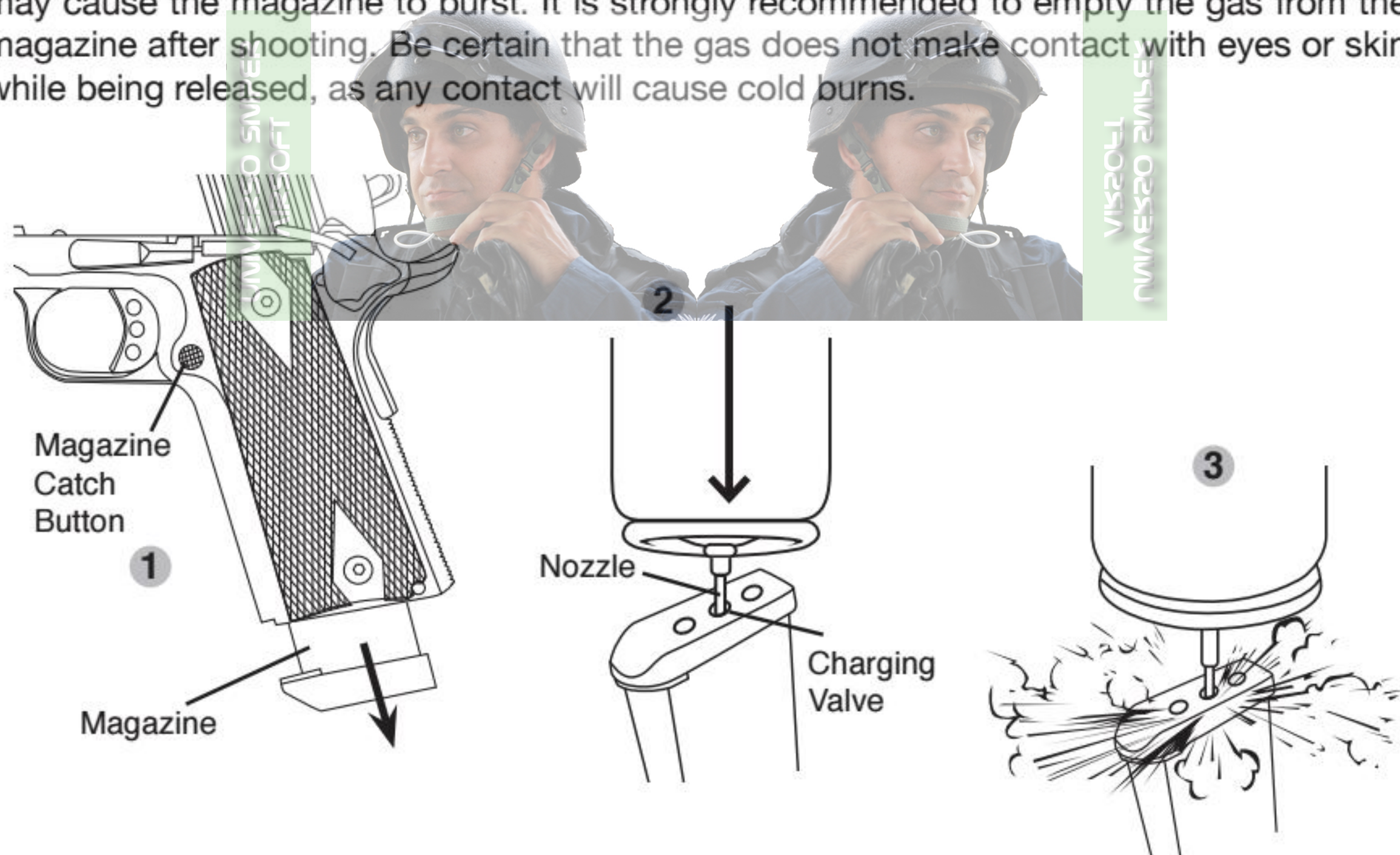

Green Gas safety tips:

- Check the canister for any cracks or leaks before using.
- Do not expose the canister to temperature over 104° F.
- Do not leave the canister directly over fire.
- Do not heat the canister.
- Keep the canister away from direct sunlight.
- Do not leave the canister in any type of vehicle.

LOADING BBs

1. Pull the magazine follower down until it locks.
2. Insert BBs into the magazine lip.
3. Make sure to have a 3mm clearance between BBs and the top lip of the magazine.
4. Push the magazine follower lock to release.



WARNING: Always use high quality 6mm BBs, weighing 0.2g or heavier. For best result use 0.25g KWA Perfect BBs. Never use recycled or low grade BBs to prevent damage to your gun.



WARNING: Do not release the magazine follower when the magazine is empty. Doing so will damage the magazine and magazine follower.

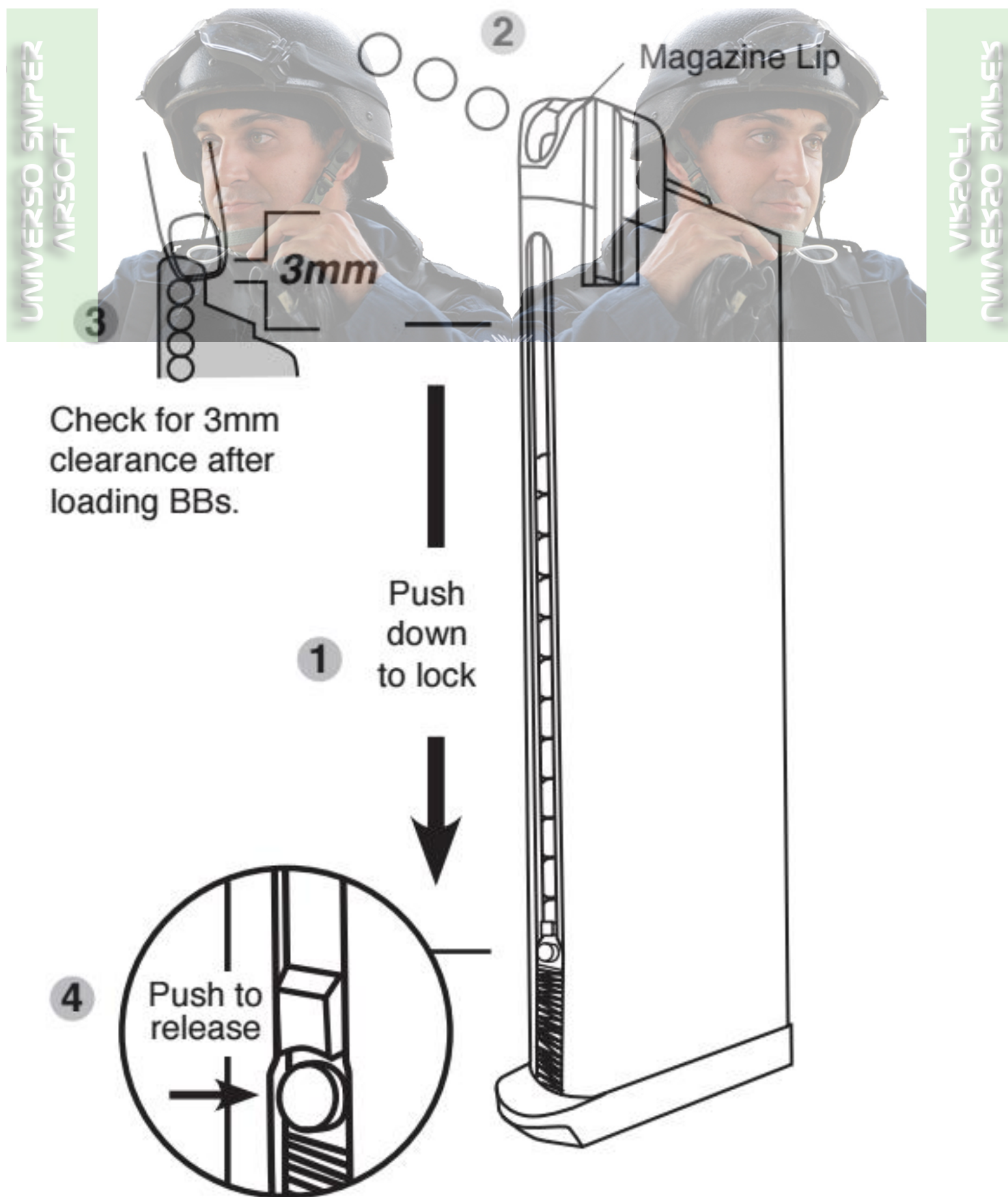

LOADING MAGAZINE

1. Place the magazine back into the magazine well.
2. Push the magazine up until it clicks into a locked position.
3. Pull the magazine down to assure that it has been locked in place.

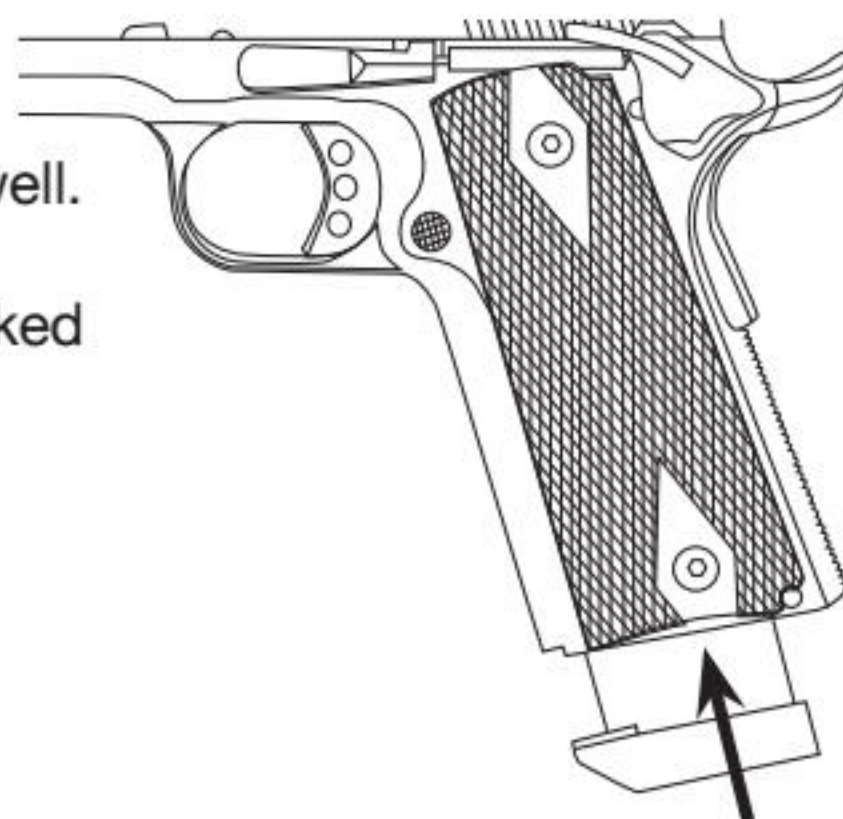

SAFETY

To engage the Safety, push the safety lever upward. The gun is not ready to fire.
(UP = ON = NOT READY TO FIRE)

To disengage the Safety, push the safety lever downward. The gun is ready to fire.
(DOWN = OFF = READY TO FIRE)

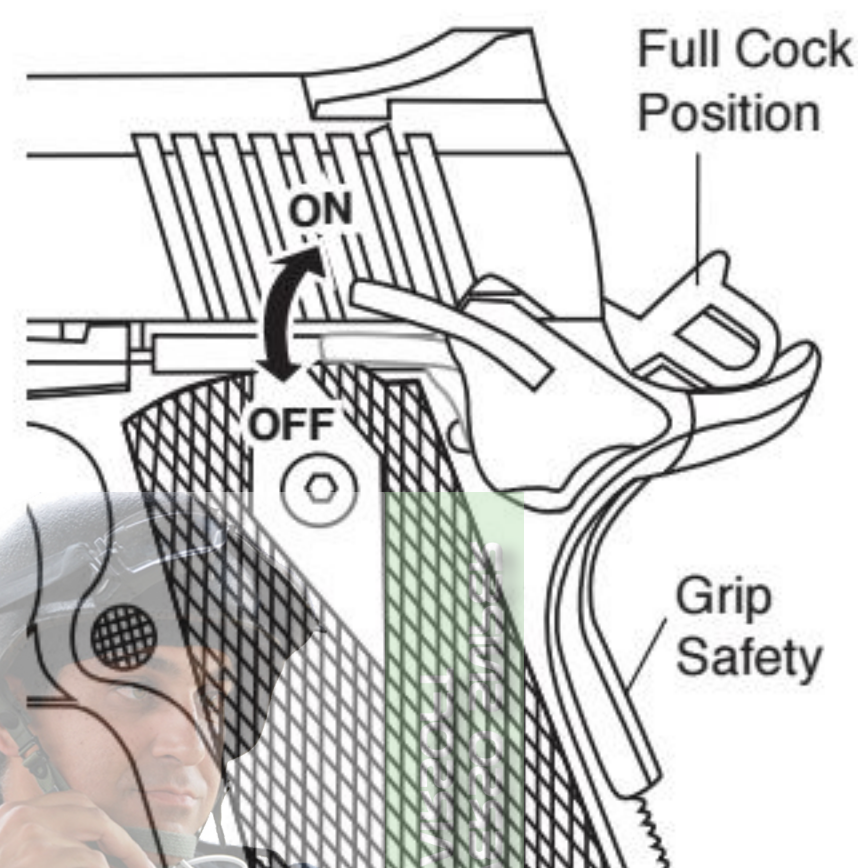

GRIP SAFETY

Grip safety is on at all times. To release grip safety, hold grip firmly and grip safety will be disengaged.

LOADING CHAMBER

Pull the slide to the rear-most position and release the slide. This will automatically load the BBs into the chamber. The hammer will be in a cocked position. Make sure not to skip this procedure. Skipping this step will cause a misfire on the first pull of the trigger. The slide will lock open when the last BB is fired.

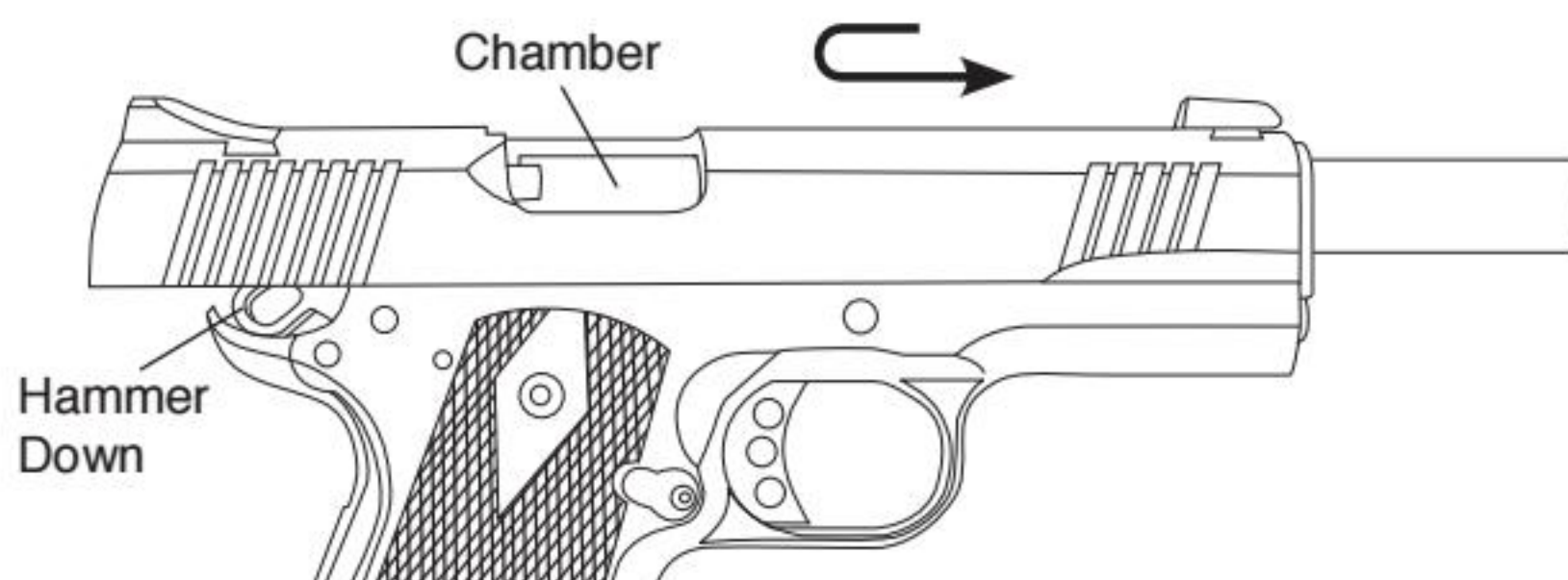

SHOOTING

1. Make sure the gun is cocked.
2. Grasp the Airsoft gun in your hand firmly. A two-hand hold with one hand wrapped around the other will help control the Airsoft gun.
3. Release safety and squeeze the trigger. The blow back action will load the following BBs automatically as the slide cycles back and forth.



WARNING: Never shoot the gun in a horizontal or upside-down position.



WARNING: Do not fire the pistol without a magazine inserted. Doing so may damage the impact block and result in the loss of the impact pin.

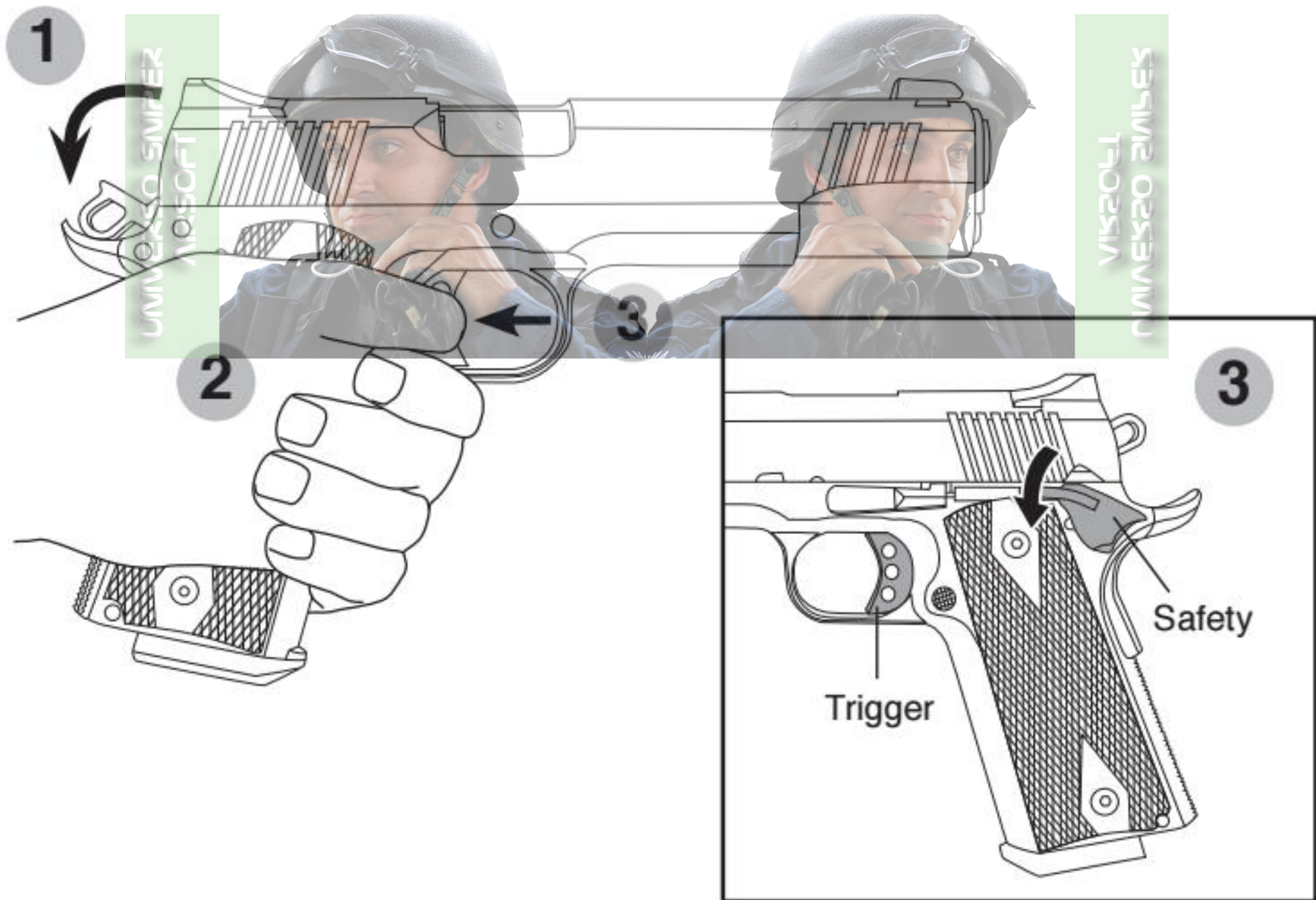

OPEN SLIDE

The slide will remain open after the last BB has been fired and ejected. Remove the empty magazine and replace it with a loaded magazine, then release the slide stop. The first BB will be automatically loaded into the chamber.

Note: It is important to treat your gun as if it were loaded even when the slide is open.

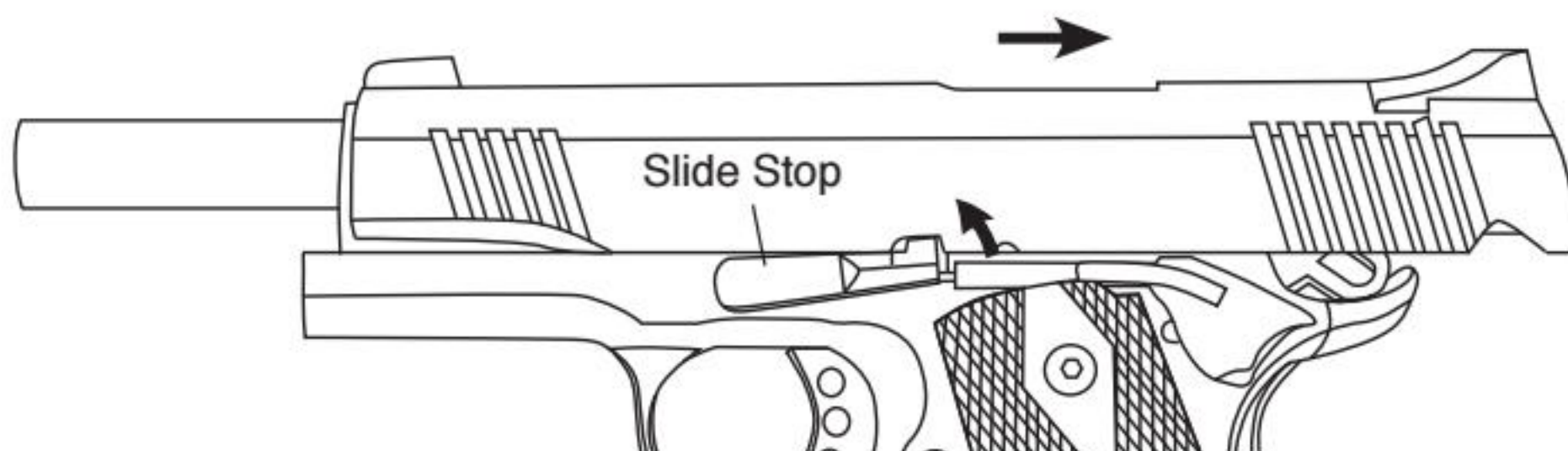

AFTER SHOOTING

After you are finished shooting, remove the magazine and visually examine the open chamber to check for clearance. Make sure both the magazine and the chamber are clear without BBs, **release the slide then engage the safety lever.**



CHECK

Make sure
chamber is
clear

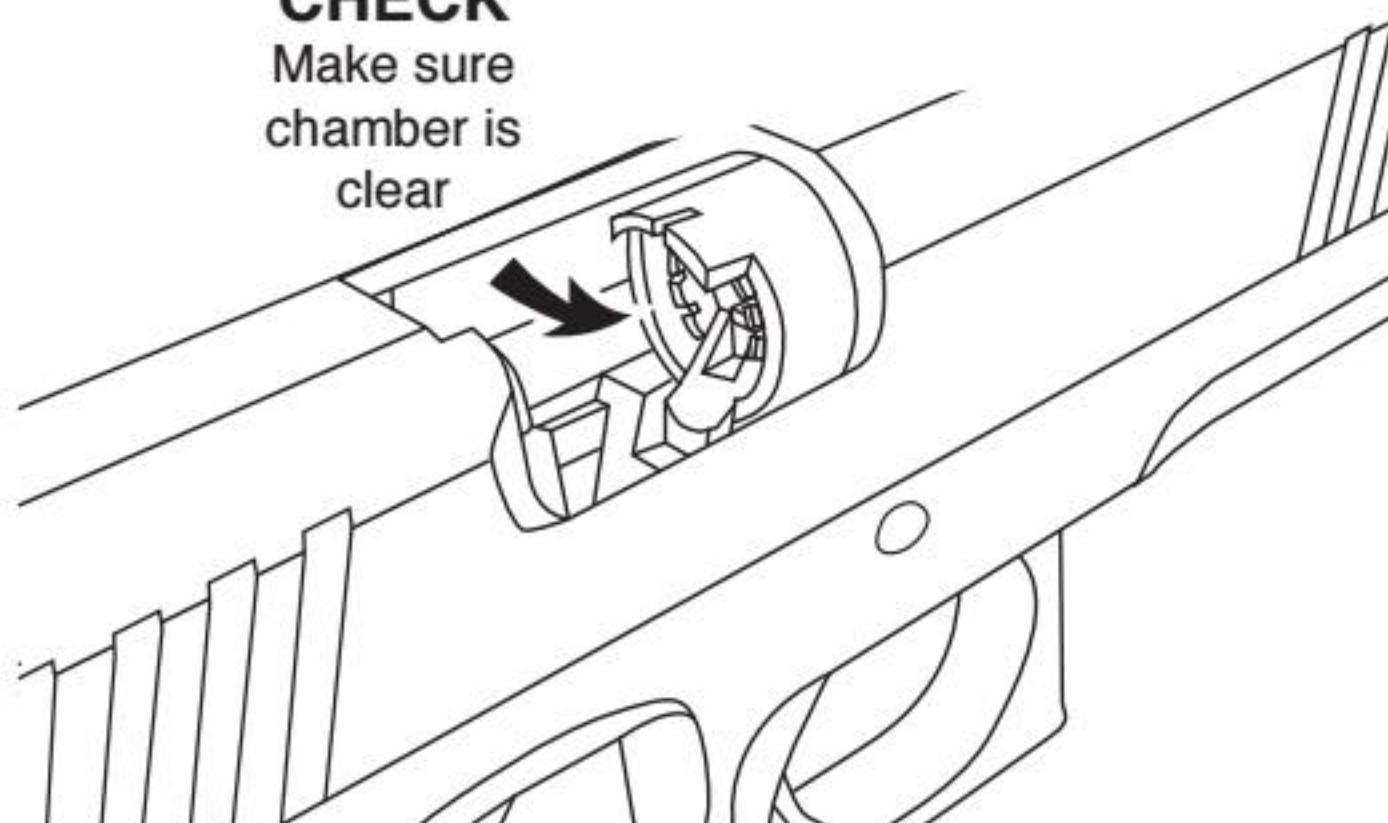

HOP-UP SYSTEM

The Hop-Up device is one of KWA's standard features, giving Airsoft BBs greater stability, further travel and consistency. Airsoft BBs are light-weight and can be affected by wind when fired. With the Hop-Up system, the trajectory of the Airsoft BBs can be adjusted according to the shooting environment or surroundings.







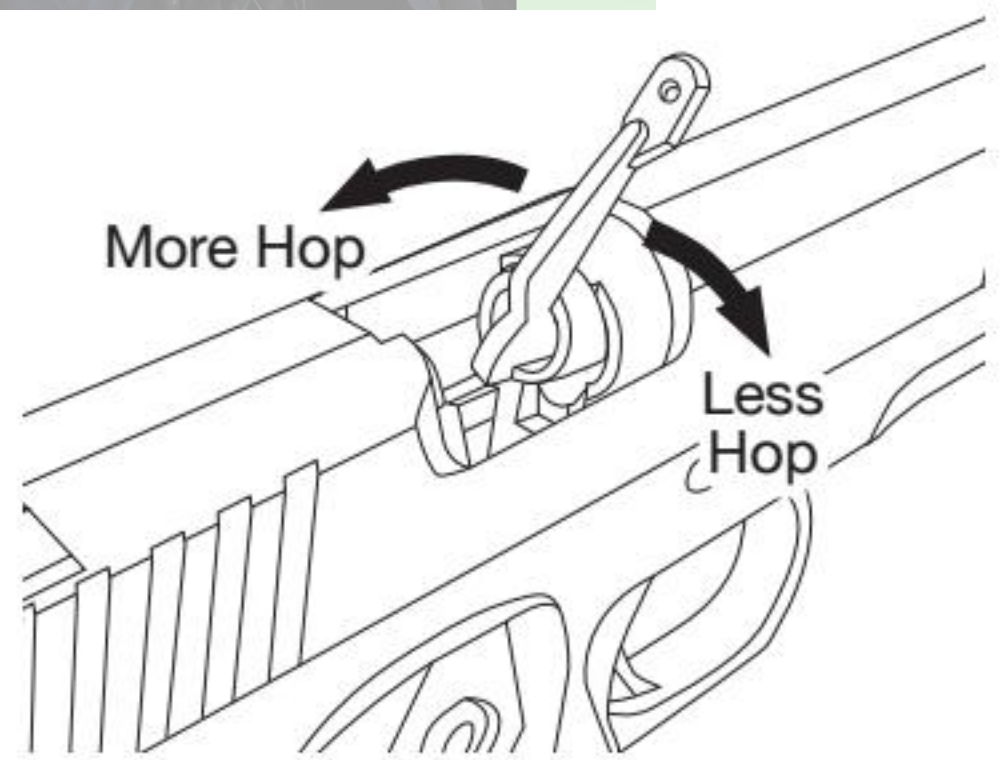
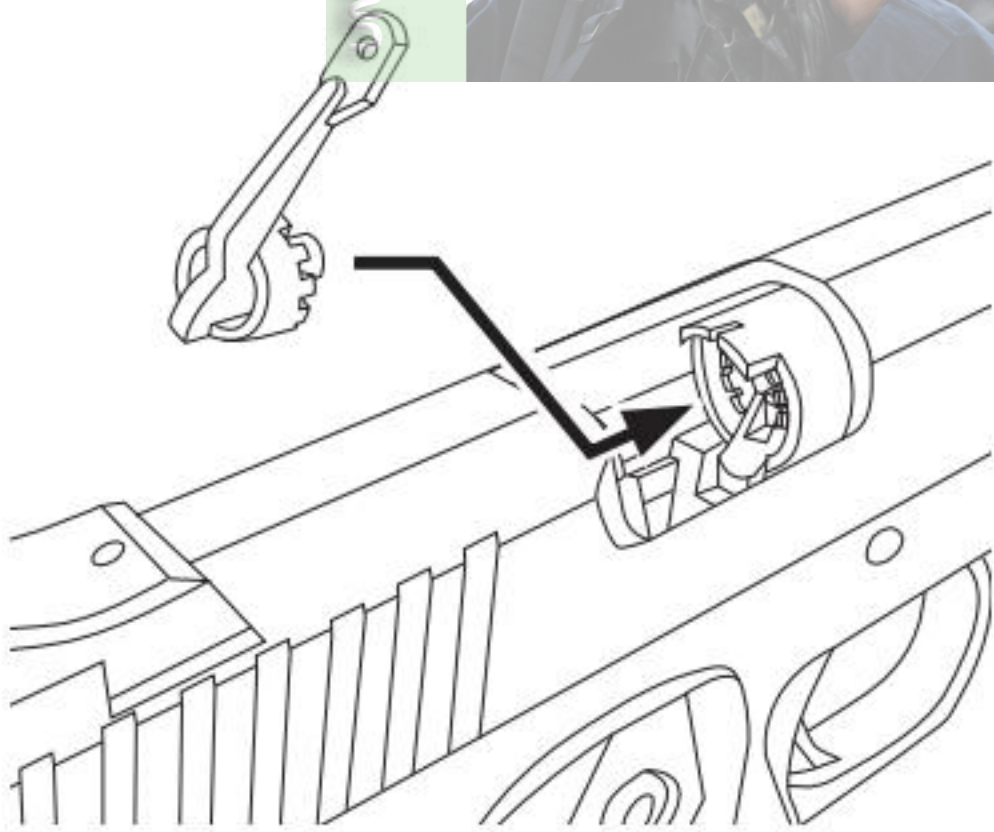



HOP-UP ADJUSTMENT

To adjust the Hop-Up, make sure the magazine is loaded and that you have at least 65 feet of clearance for a test fire before making any adjustments.

1. Test fire the gun for 10 to 20 rounds and observe the BB's traveling pattern.
2. Remove the magazine.
3. Open the slide and place adjusting tool into the slotted chamber ring. Turn the adjusting ring a 1/4-inch at a time.
4. If the BBs are dropping too quickly, move the adjusting ring to the left or counter-clockwise to give the BB more hop. If the BBs are dropping too slowly, move the adjusting ring to the right or clock-wise.
5. Test fire and adjust as needed.



HOP-UP ADJUSTMENT POINT

BB TRAJECTORY PATTERN		ADJUSTMENTS
	BB DROPS FREELY	 TURN KNOB TO LEFT
	BB TRAVELS AT SHORT TRAJECTORY PATH	 TURN KNOB SLIGHTLY TO LEFT
	BB TRAVELS DISTANCE AT FLAT TRAJECTORY PATH	 NO ADJUSTMENT MADE
	BB TRAVELS FLAT IN SHORT DISTANCE, THEN GOES UP IN CURVE AND DROPS FREELY	 TURN KNOB SLIGHTLY TO RIGHT
	BB TRAVELS AT UNSTABLE SPEED AND IRREGULAR PATH	 TURN KNOB TO RIGHT



DISASSEMBLY

It is not recommended to disassemble the gun unless you have BBs jammed inside the barrel or for maintenance purpose only.

1. Remove magazine by depressing the magazine catch button.
2. Check and clear the chamber of BBs.
3. Pull back the slide until small cut out slot on the slide aligns with the front end of the slide stop.
4. While holding the slide in position, remove the slide stop by pushing on the release pin on the right side of frame. Pull off the slide-stop from the left side of the frame.
5. Glide the slide forward, away from the frame.

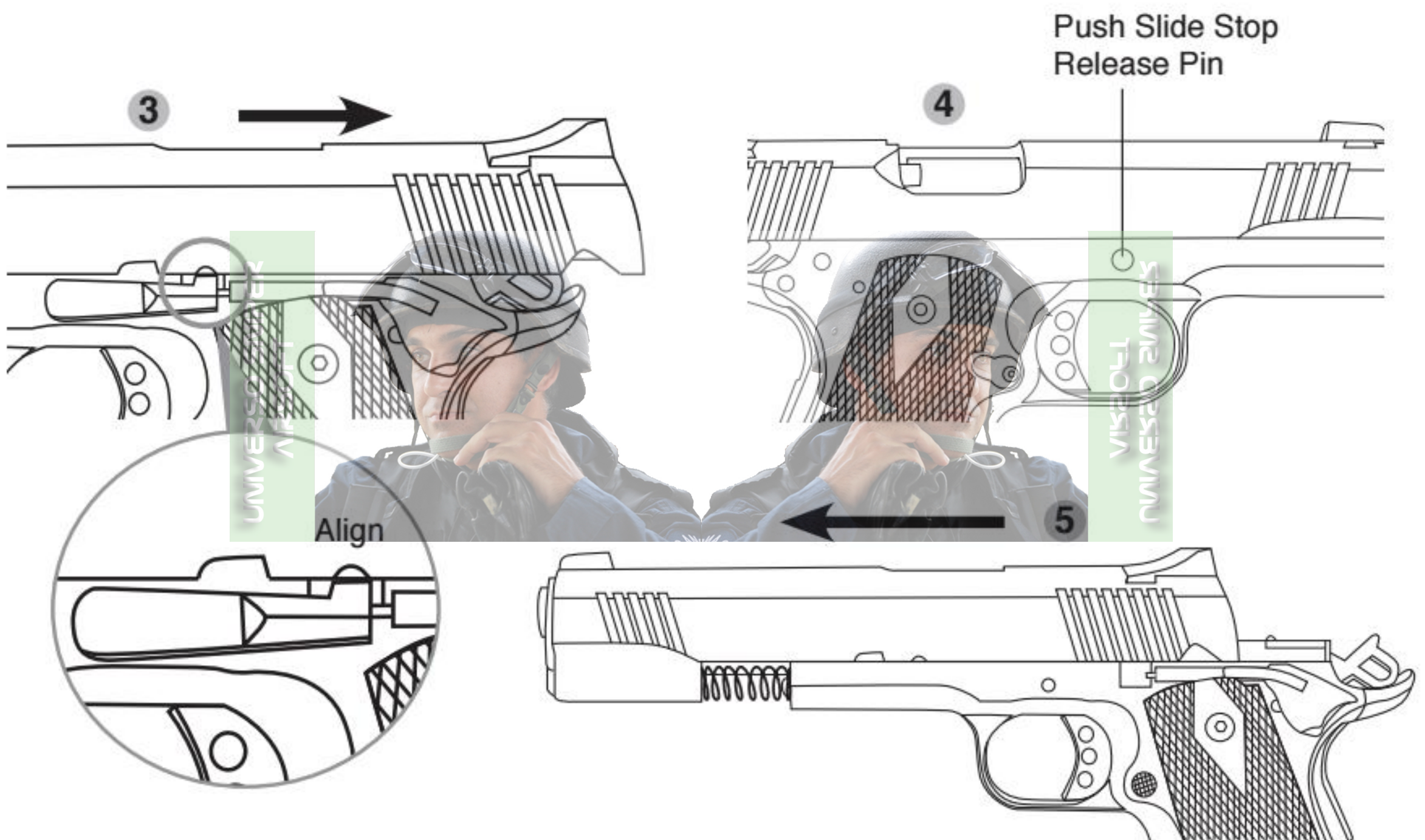

ASSEMBLY

1. Put the slide onto the frame rails. Glide it toward the rear of the Airsoft gun until the small cut-out slot on the slide aligns with the slide stop hole.
2. While holding the slide in position, insert the slide-stop.
3. Pull the slide to the rear-most position and then release.
4. Install the magazine.

NOTE: After the slide assembly is completed, cycle the slide back and forth to ensure proper assembly.

BASIC TROUBLESHOOTING GUIDE FOR PISTOL

SYMPTOMS	POSSIBLE CAUSE	SOLUTIONS
Slide jams / Will not complete cycle	Dry internals	Add silicone to cylinder / main seal/ rails
Double feeds BBs into chamber / BB's roll out of barrel	Hop-up adjustment too tight	Release hop-up or replace bucking
BBs will not release from magazine / bent mag lip/ check bb condition	Bent magazine lip	Replace magazine lip
Leaking release valve & charging valve	Dry O-ring	Add silicone oil to valves / Replace valves
Slide stop engages while shooting BBs	Weak slide stop spring	Adjust tension
Magazine base plate will not lock	Broken base plate lock	Replace base plate lock
Magazine base leaking air	Worn out base seal	Replace magazine base seal
Cylinder will not load BBs into chamber	Broken cylinder tap	Replace cylinder
Trigger will not reset	Worn out trigger spring / trigger bow spring	Replace trigger spring / trigger bow spring



GENERAL MAINTENANCE FOR KWA GAS BLOW BACK

Green gas is a liquid propellant which tends to dry out the seals and o-rings. With lubricating silicone oil, it will extend the life of the seals and o-rings and prevent gas leaks.

Use only the recommended 100% silicone oil, available for purchase at the Airsoft dealer where you purchased your KWA products. Any other type of lubricant may damage the products.

Lightly lubricate the recoil spring, cylinder and moving parts with a few drops of oil. Lubricating the seals and o-rings are essential. Unload BBs from the magazine. Make sure the magazine is free of gas before lubricating the magazine's charging valve and release valve.

OPERATING UNDER UNUSUAL CONDITIONS

Unusual conditions are defined as any condition requiring special maintenance. Perform maintenance outlined for the climate similar to your operational area

Extreme Cold:

Operating an Airsoft gas gun in extremely cold temperatures is not recommended. Cold temperatures will cause the Hop-up Bucking to harden, reducing its effectiveness. Gas will not expand properly in cold temperatures, so both the cycling rate and power will be dramatically reduced.

Extreme Heat:

Operating an Airsoft gas gun in extremely hot temperatures is also not recommended. Leaving the gun in direct sunlight for long periods of time, or operating in extremely hot areas will cause the gas to over-expand, damaging the internal workings of the gun. The increase in internal pressure from the expanding gas can also damage the seals and cause leaks in the magazine.

Dust or Sand:

Dust or sand can get into a gas gun and cause malfunctions and/or excessive wear. Keep the gun covered whenever possible. Use lubricant sparingly, as lube naturally attracts dirt and other particles. After use in a dusty area, always field strip the gun (refer to Disassembly Section) and clean any areas you can reach with a soft, lint-free cloth.

1911 MARK I DIAGRAM

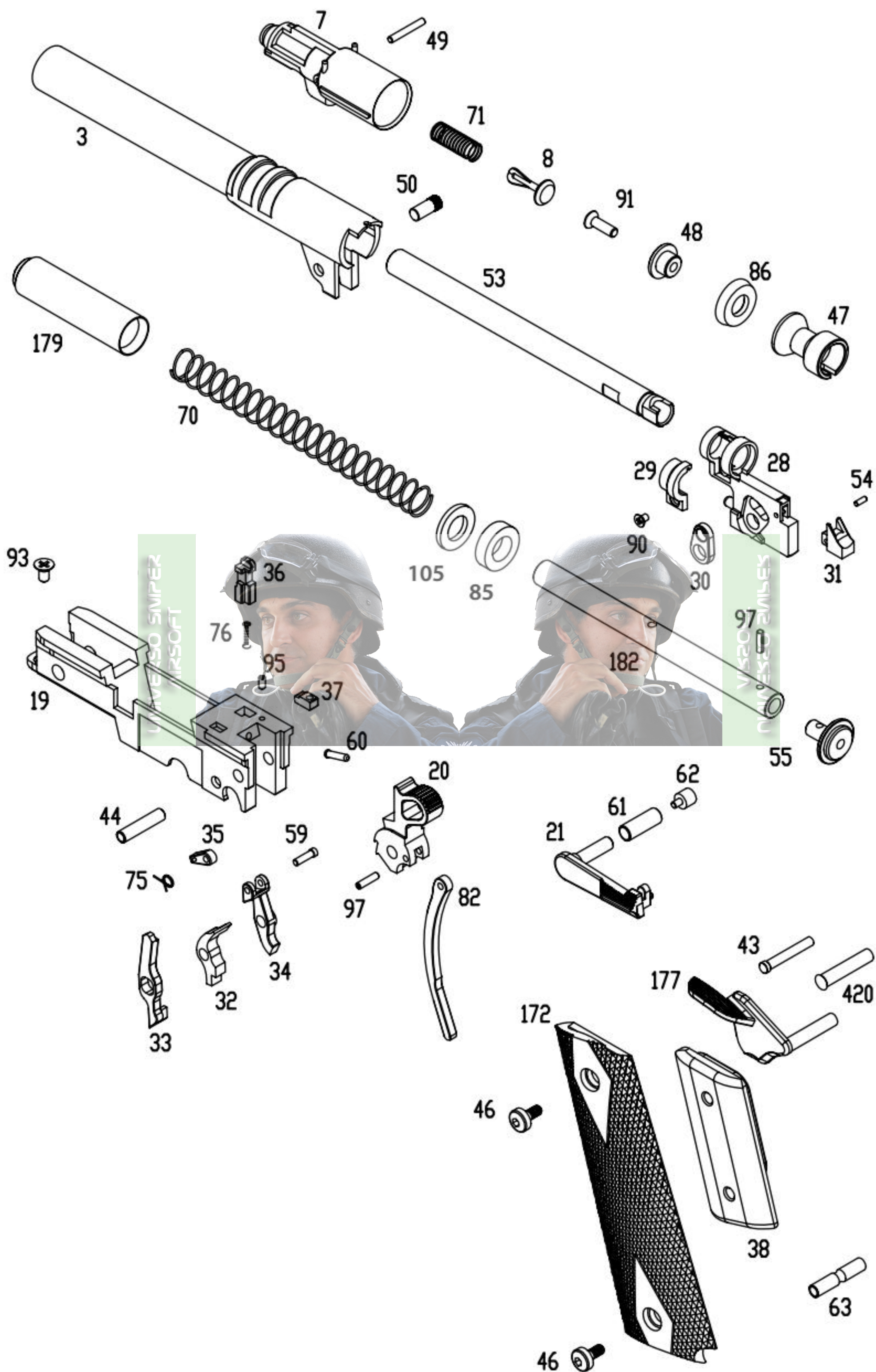

1911 MARK I DIAGRAM

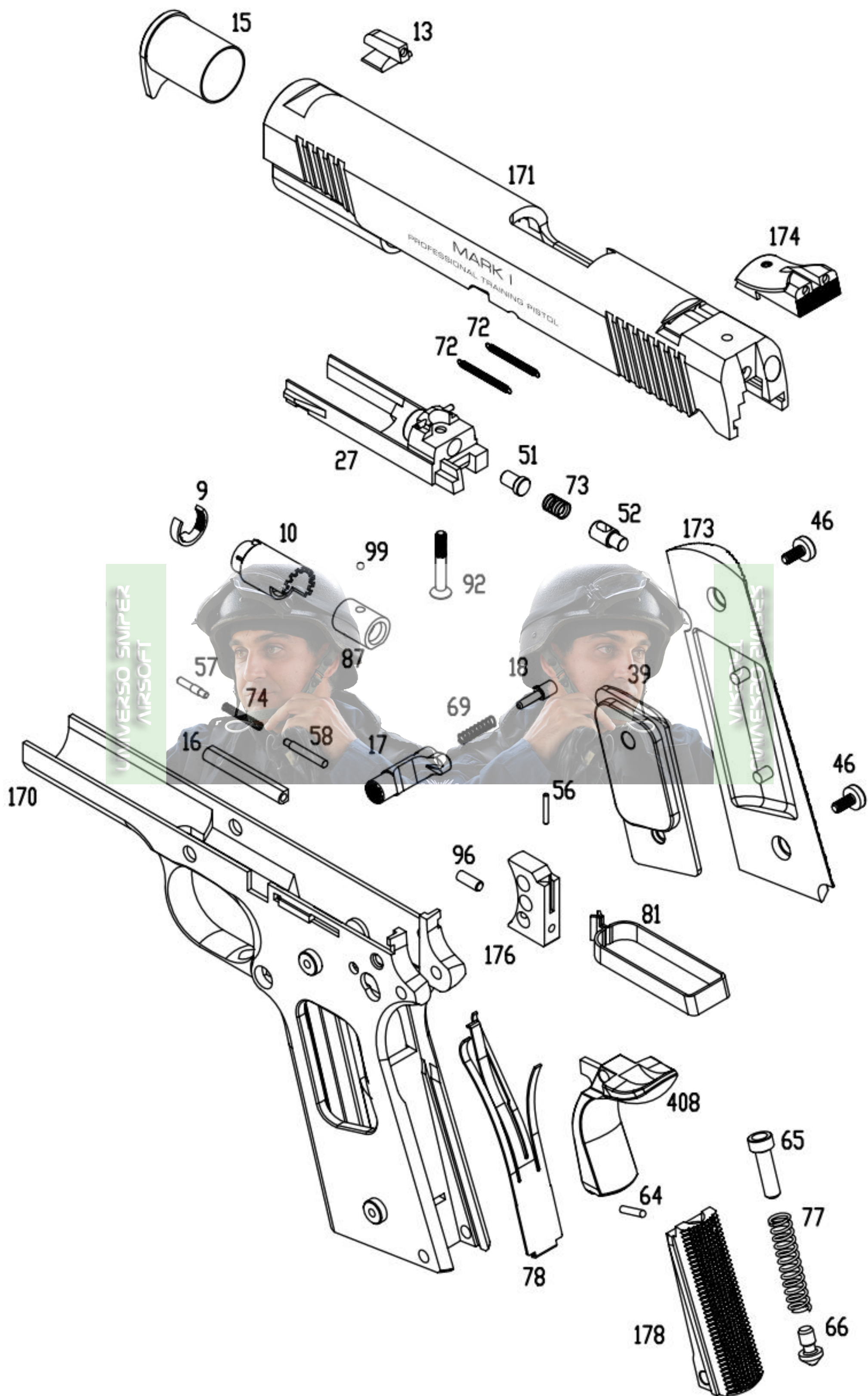

1911 MARK I PARTS LIST

Parts #	Description	Parts #	Description	Parts #	Description
MK I-3	OUTER BARREL	MK I-54	BB FEED RAMP PIN	MK I-96	TRIGGER SCREW
MK I-7	CYLINDER	MK I-55	RECOIL SPRING GUIDE CAP	MK I-97	ROLL PINS X 2
MK I-8	JET NOZZLE	MK I-56	TRIGGER BAR LOCK PIN	MK I-99	HOP-UP BALL
MK I-9	HOP-UP CYLINDER CLAMP	MK I-57	SLIDE RELEASE LEVER PLUNGER	MK I-105	RECOIL BUFFER WASHER
MK I-10	HOP-UP CYLINDER	MK I-58	SAFETY LEVER PLUNGER	MK I-170	FRAME
MK I-13	FRONT SIGHT	MK I-59	IMPACT BLOCK PIN	MK I-171	SLIDE
MK I-15	BARREL BUSHING	MK I-60	IMPACT PIN	MK I-172	GRIP (LEFT)
MK I-16	PLUNGER TUBE	MK I-61	SLIDE RELEASE SLEEVE	MK I-173	GRIP (RIGHT)
MK I-17	MAGAZINE CATCH	MK I-62	SLIDE RELEASE CAP	MK I-174	REAR SIGHT
MK I-18	MAGAZINE CATCH LOCK	MK I-63	MAIN SPRING HOUSING PIN	MK I-176	TRIGGER
MK I-19	INNER FRAME BASE	MK I-64	MAIN SPRING RETAINER PIN	MK I-177	SAFETY LEVER
MK I-20	HAMMER	MK I-65	MAIN SPRING RETAINER	MK I-178	MAIN SPRING HOUSING
MK I-21	SLIDE CATCH LEVER	MK I-66	MAIN SPRING CATCH	MK I-179	RECOIL SPRING PLUG
MK I-27	BREECH BLOCK	MK I-69	MAGAZINE CATCH SPRING	MK I-182	RECOIL SPRING GUIDE
MK I-28	INNER BARREL BASE	MK I-70	RECOIL SPRING	MK I-408	GRIP SAFETY
MK I-29	INNER BARREL LOCK	MK I-71	JET NOZZLE SPRING	MK I-420	HAMMER PIN
MK I-30	BARREL LINK	MK I-72	CYLINDER SPRINGS X 2		
MK I-31	BB FEED RAMP	MK I-73	FIRING PIN SPRING		
MK I-32	SEAR	MK I-74	PLUNGER SPRING		
MK I-33	DISCONNECTOR	MK I-75	IMPACT BLOCK SPRING		
MK I-34	IMPACT FRAME	MK I-76	IMPACT BLOCK LOCK SPRING		
MK I-35	IMPACT BLOCK	MK I-77	MAIN SPRING		
MK I-36	IMPACT BLOCK LOCK	MK I-78	SEAR SPRING		
MK I-37	IMPACT BLOCK STOPPER	MK I-81	TRIGGER BOW		
MK I-38	GRIP WEIGHT (LEFT)	MK I-82	HAMMER STRUT		
MK I-39	GRIP WEIGHT (RIGHT)	MK I-85	RECOIL BUFFER		
MK I-43	SEAR PIN	MK I-86	MAIN SEAL		
MK I-44	SEAR SLEEVE	MK I-87	HOP-UP BUCKING		
MK I-46	GRIP SCREWS X 4	MK I-90	INNER BARREL LOCK SCREW		
MK I-47	MAIN SEAL BASE	MK I-91	MAIN SEAL CAP SCREW		
MK I-48	MAIN SEAL CAP	MK I-92	BREECH SCREW		
MK I-49	JET NOZZLE PIN	MK I-93	INNER FRAME SCREW		
MK I-50	BARREL LINK PIN	MK I-95	IMPACT BLOCK LOCK STOPPER SCREW		
MK I-51	MAIN SEAL BASE SCREW				
MK I-52	FIRING PIN				
MK I-53	INNER BARREL				

1911 MARK II PARTS DIAGRAM

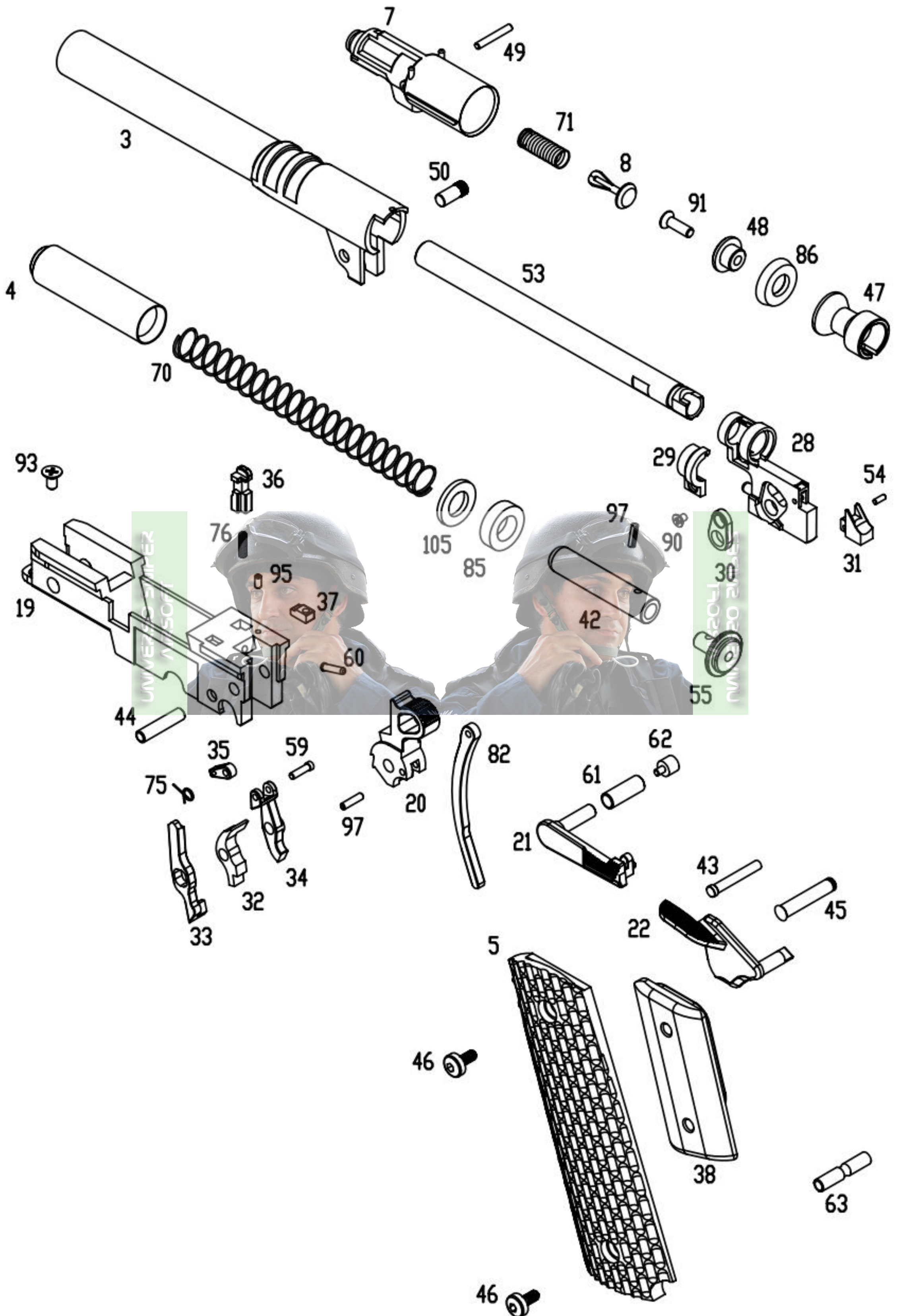

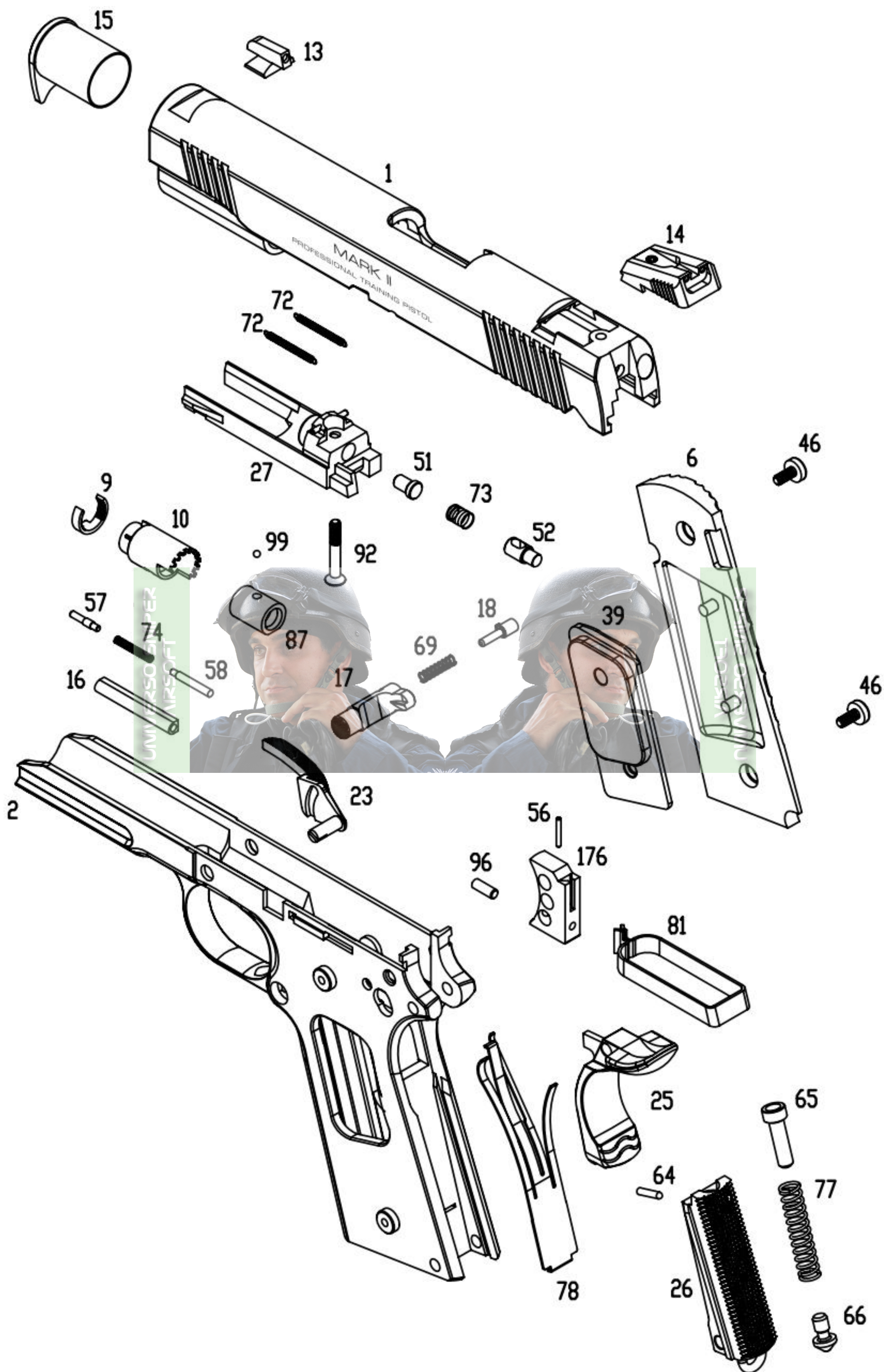

1911 MARK II PARTS LIST

Parts #	Description
MK II-1	SLIDE
MK II-2	MAIN FRAME
MK II-3	OUTER BARREL
MK II-4	FLAT RECOIL PLUG
MK II-5	WAFFLE GRIP (LEFT)
MK II-6	WAFFLE GRIP (RIGHT)
MK II-7	CYLINDER
MK II-8	JET NOZZLE
MK II-9	HOP-UP CYLINDER CLAMP
MK II-10	HOP-UP CYLINDER
MK II-13	FRONT SIGHT
MK II-14	REAR SIGHT
MK II-15	BARREL BUSHING
MK II-16	PLUNGER TUBE
MK II-17	MAGAZINE CATCH
MK II-18	MAGAZINE CATCH LOCK
MK II-19	INNER FRAME BASE
MK II-20	HAMMER
MK II-21	SLIDE CATCH LEVER
MK II-22	SAFETY LEVER (LEFT)
MK II-23	SAFETY LEVER (RIGHT)
MK II-25	GRIP SAFETY A
MK II-26	MAIN SPRING HOUSING
MK II-27	BREECH BLOCK
MK II-28	INNER BARREL BASE
MK II-29	INNER BARREL LOCK
MK II-30	BARREL LINK
MK II-31	BB FEED RAMP
MK II-32	SEAR
MK II-33	DISCONNECTOR
MK II-34	IMPACT FRAME
MK II-35	IMPACT BLOCK
MK II-36	IMPACT BLOCK LOCK
MK II-37	IMPACT BLOCK LOCK STOPPER
MK II-38	GRIP WEIGHT (LEFT)
MK II-39	GRIP WEIGHT (RIGHT)

Parts #	Description
MK II-42	RECOIL SPRING GUIDE ROD
MK II-43	SEAR PIN
MK II-44	SEAR SLEEVE
MK II-45	HAMMER PIN
MK II-46	GRIP SCREWS X 4
MK II-47	MAIN SEAL BASE
MK II-48	MAIN SEAL CAP
MK II-49	JET NOZZLE PIN
MK II-50	BARREL LINK PIN
MK II-51	MAIN SEAL BASE SCREW
MK II-52	FIRING PIN
MK II-53	INNER BARREL
MK II-54	BB FEED RAMP PIN
MK II-55	RECOIL SPRING GUIDE CAP
MK II-56	TRIGGER BAR LOCK PIN
MK II-57	SLIDE RELEASE LEVER
MK II-58	SAFETY LEVER PLUNGER
MK II-59	IMPACT BLOCK PIN
MK II-60	IMPACT PIN
MK II-61	SLIDE RELEASE SLEEVE
MK II-62	SLIDE RELEASE CAP
MK II-63	MAIN SPRING HOUSING PIN
MK II-64	MAIN SPRING RETAINER PIN
MK II-65	MAIN SPRING RETAINER
MK II-66	MAIN SPRING CATCH
MK II-69	MAGAZINE CATCH SPRING
MK II-70	RECOIL SPRING
MK II-71	JET NOZZLE SPRING
MK II-72	CYLINDER SPRINGS X 2
MK II-73	FIRING PIN SPRING
MK II-74	PLUNGER SPRING
MK II-75	IMPACT BLOCK SPRING
MK II-76	IMPACT BLOCK LOCK SPRING
MK II-77	MAIN SPRING
MK II-78	SEAR SPRING
MK II-81	TRIGGER BOW
MK II-82	HAMMER STRUT

Parts #	Description
MK II-85	RECOIL BUFFER
MK II-86	MAIN SEAL
MK II-87	HOP-UP BUCKING
MK II-90	INNER BARREL LOCK SCREW
MK II-91	MAIN SEAL CAP SCREW
MK II-92	BREECH SCREW
MK II-93	INNER FRAME BASE SCREW
MK II-95	IMPACT BLOCK LOCK STOPPER SCREW
MK II-96	TRIGGER SCREW
MK II-97	ROLL PINS X 2
MK II-99	HOP-UP BALL
MK II-105	RECOIL BUFFER WASHER
MK II-176	TRIGGER



1911 MARK III PARTS DIAGRAM

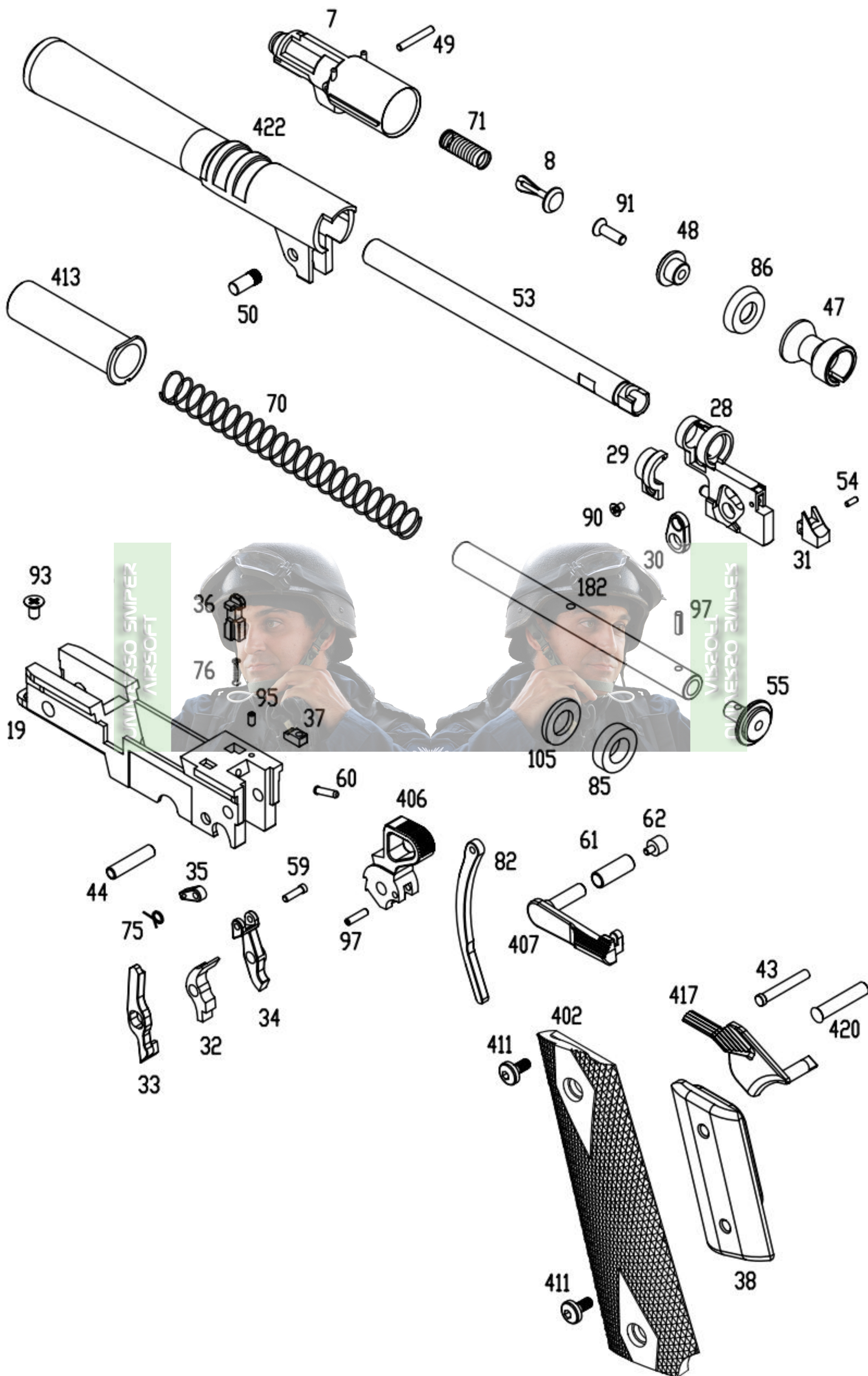

1911 MARK III PARTS DIAGRAM

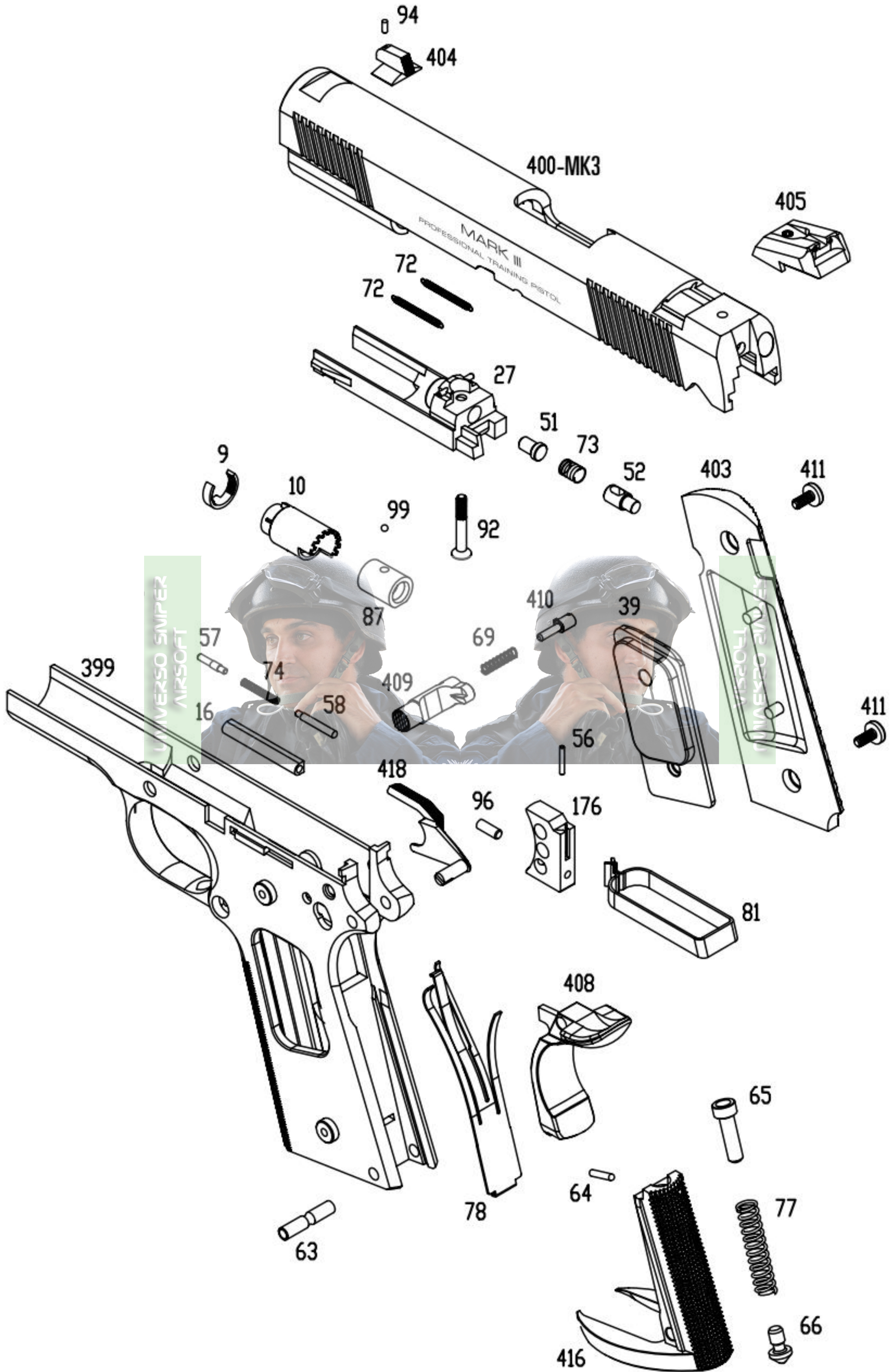

1911 MARK III PARTS LIST

Parts #	Description	Parts #	Description	Parts #	Description
MK III-7	CYLINDER	MK III-62	SLIDE RELEASE CAP	MK III-402	GRIP (LEFT)
MK III-8	JET NOZZLE	MK III-63	MAIN SPRING HOUSING PIN	MK III-403	GRIP (RIGHT)
MK III-9	HOP-UP CYLINDER CLAMP	MK III-64	MAIN SPRING RETAINER PIN	MK III-404	FRONT SIGHT
MK III-10	HOP-UP CYLINDER	MK III-65	MAIN SPRING RETAINER	MK III-405	REAR SIGHT
MK III-16	PLUNGER TUBE	MK III-66	MAIN SPRING CATCH	MK III-406	DELTA HAMMER
MK III-19	INNER FRAME BASE	MK III-69	MAGAZINE CATCH SPRING	MK III-407	SLIDE RELEASE LEVER
MK III-27	BREECH BLOCK	MK III-70	RECOIL SPRING	MK III-408	GRIP SAFETY
MK III-28	INNER BARREL BASE	MK III-71	JET NOZZLE SPRING	MK III-409	MAGAZINE CATCH
MK III-29	INNER BARREL BASE LOCK	MK III-72	CYLINDER SPRINGS X 2	MK III-410	MAGAZINE CATCH LOCK
MK III-30	BARREL LINK	MK III-73	FIRING PIN SPRING	MK III-411	GRIP SCREWS X 4
MK III-31	BB FEED RAMP	MK III-74	PLUNGER SPRING	MK III-413	RECOIL PLUG
MK III-32	SEAR	MK III-75	IMPACT BLOCK SPRING	MK III-416	MAIN SPRING HOUSING
MK III-33	DISCONNECTOR	MK III-76	IMPACT BLOCK LOCK SPRING	MK III-417	SAFETY LEVER (LEFT)
MK III-34	IMPACT FRAME	MK III-77	MAIN SPRING	MK III-418	SAFETY LEVER (RIGHT)
MK III-35	IMPACT BLOCK	MK III-78	SEAR SPRING	MK III-420	HAMMER PIN
MK III-36	IMPACT BLOCK LOCK	MK III-81	TRIGGER BOW	MK III-422	OUTER BARREL
MK III-37	IMPACT BLOCK LOCK STOPPER	MK III-82	HAMMER STRUT		
MK III-38	GRIP WEIGHT (LEFT)	MK III-85	RECOIL BUFFER		
MK III-39	GRIP WEIGHT (RIGHT)	MK III-86	MAIN SEAL		
MK III-43	SEAR PIN	MK III-87	HOP-UP BUCKING		
MK III-44	SEAR SLEEVE	MK III-90	INNER BARREL CLAMP SCREW		
MK III-47	MAIN SEAL BASE	MK III-91	MAIN SEAL CAP SCREW		
MK III-48	MAIN SEAL CAP	MK III-92	BREECH SCREW		
MK III-49	JET NOZZLE PIN	MK III-93	INNER FRAME BASE SCREW		
MK III-50	BARREL LINK PIN	MK III-94	FRONT SIGHT SCREW		
MK III-51	MAIN SEAL BASE SCREW	MK III-95	IMPACT BLOCK LOCK STOPPER SCREW		
MK III-52	FIRING PIN	MK III-96	TRIGGER SCREW		
MK III-53	INNER BARREL	MK III-97	ROLL PINS X 2		
MK III-54	BB FEED RAMP PIN	MK III-99	HOP-UP BALL		
MK III-55	RECOIL SPRING GUIDE CAP	MK III-105	RECOIL BUFFER WASHER		
MK III-56	TRIGGER BAR LOCK PIN	MK III-176	TRIGGER		
MK III-57	SLIDE RELEASE LEVER PLUNGER	MK III-182	RECOIL SPRING GUIDE ROD		
MK III-58	SAFETY LEVER PLUNGER	MK III-399	FRAME		
MK III-59	IMPACT BLOCK PIN	MK III-400-MK3	SLIDE		
MK III-60	IMPACT PIN				
MK III-61	SLIDE RELEASE SLEEVE				

1911 MARK IV PARTS DIAGRAM

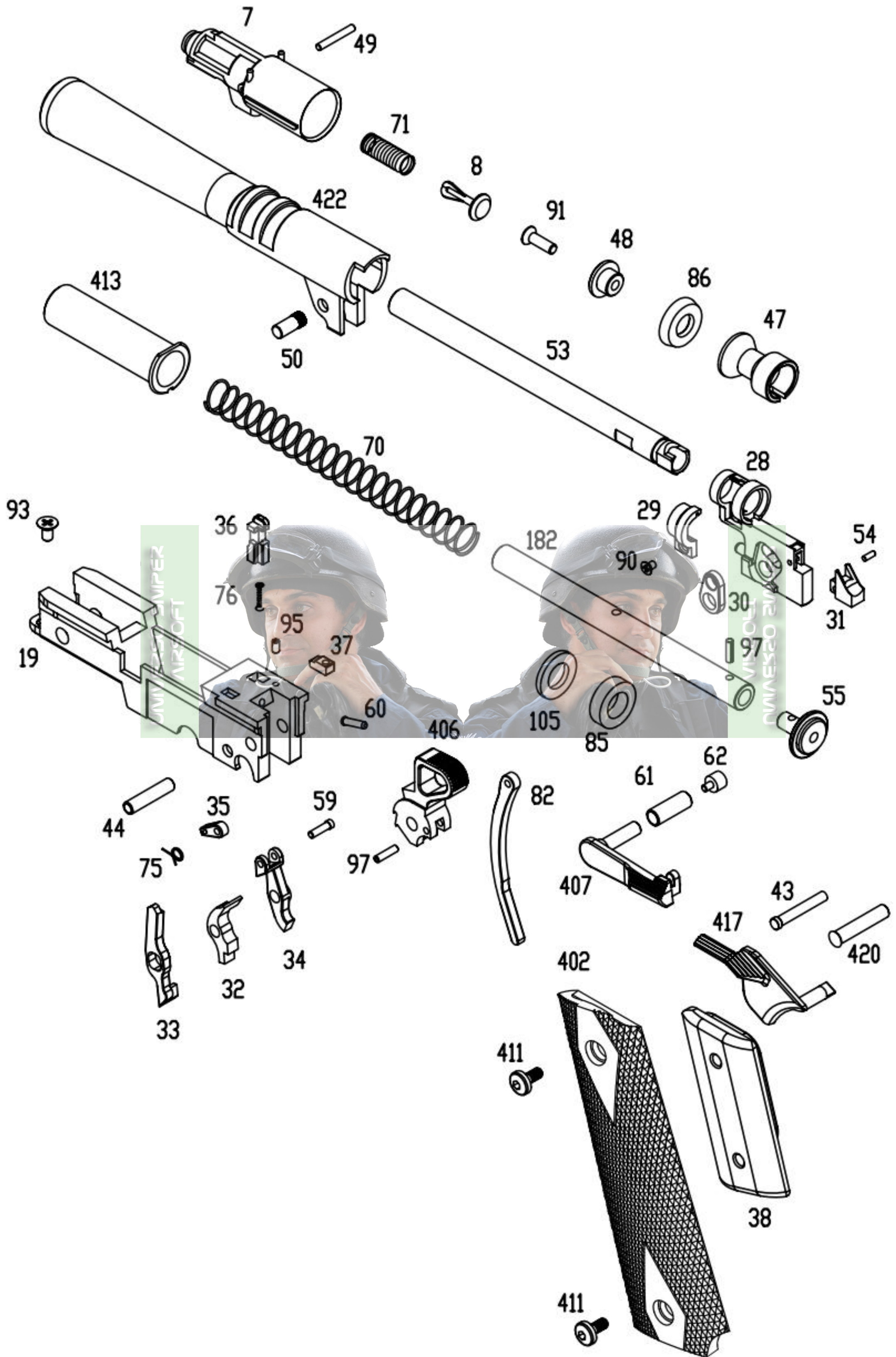

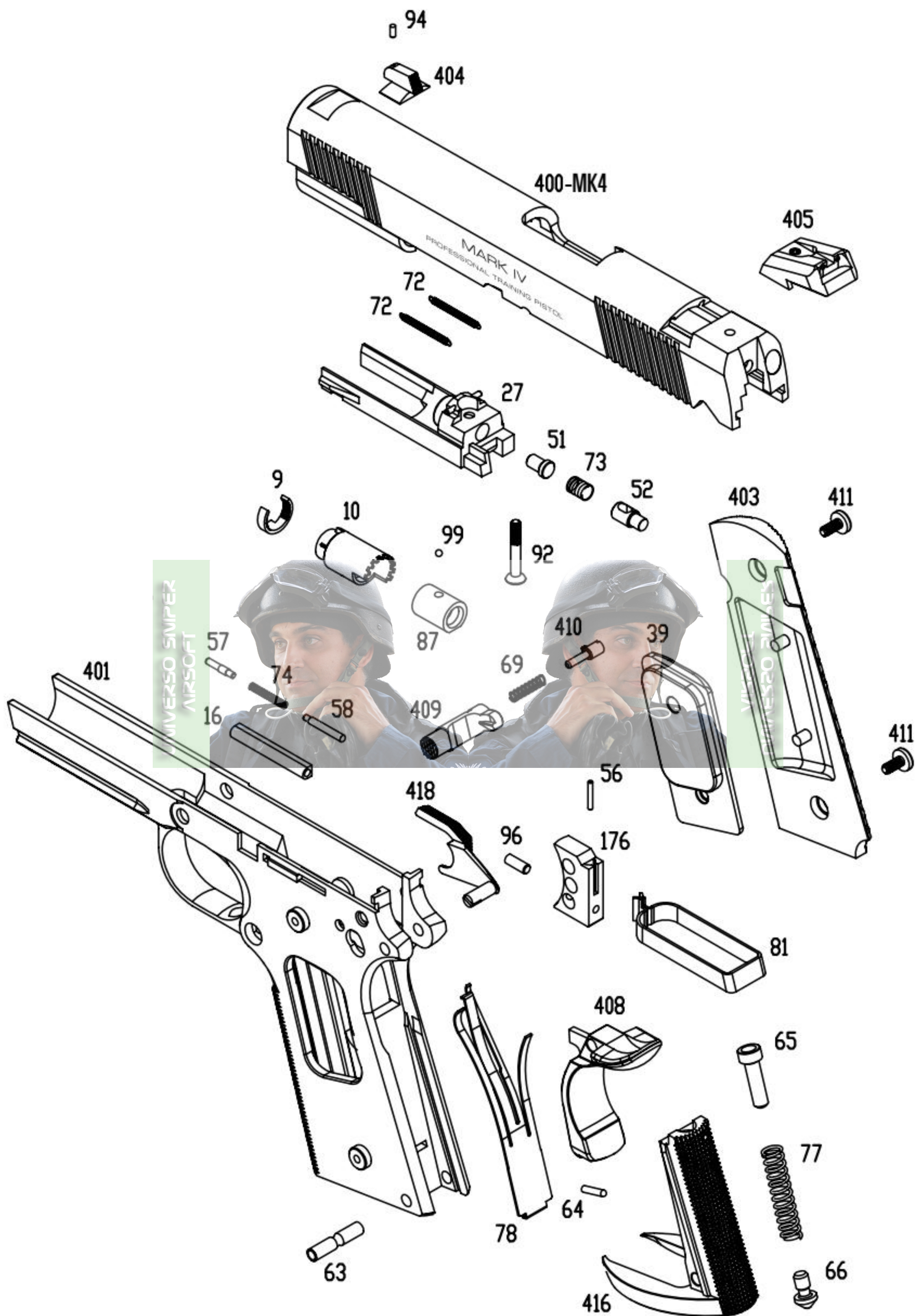

1911 MARK IV PARTS LIST

Parts #	Description
MK IV-7	CYLINDER
MK IV-8	JET NOZZLE
MK IV-9	HOP-UP CYLINDER CLAMP
MK IV-10	HOP-UP CYLINDER
MK IV-16	PLUNGER TUBE
MK IV-19	INNER FRAME BASE
MK IV-27	BREECH BLOCK
MK IV-28	INNER BARREL BASE
MK IV-29	INNER BARREL LOCK
MK IV-30	BARREL LINK
MK IV-31	BB FEED RAMP
MK IV-32	SEAR
MK IV-33	DISCONNECTOR
MK IV-34	IMPACT FRAME
MK IV-35	IMPACT BLOCK
MK IV-36	IMPACT BLOCK LOCK
MK IV-37	IMPACT BLOCK LOCK STOPPER
MK IV-38	GRIP WEIGHT (LEFT)
MK IV-39	GRIP WEIGHT (RIGHT)
MK IV-43	SEAR PIN
MK IV-44	SEAR SLEEVE
MK IV-47	MAIN SEAL BASE
MK IV-48	MAIN SEAL CAP
MK IV-49	JET NOZZLE PIN
MK IV-50	BARREL LINK PIN
MK IV-51	MAIN SEAL BASE SCREW
MK IV-52	FIRING PIN
MK IV-53	INNER BARREL
MK IV-54	BB FEED RAMP PIN
MK IV-55	RECOIL SPRING GUIDE CAP
MK IV-56	TRIGGER BAR LOCK PIN
MK IV-57	SLIDE RELEASE LEVER PLUNGER
MK IV-58	SAFETY LEVER PLUNGER
MK IV-59	IMPACT BLOCK PIN
MK IV-60	IMPACT PIN

Parts #	Description
MK IV-61	SLIDE RELEASE SLEEVE
MK IV-62	SLIDE RELEASE CAP
MK IV-63	MAIN SPRING HOUSING PIN
MK IV-64	MAIN SPRING RETAINER PIN
MK IV-65	MAIN SPRING RETAINER
MK IV-66	MAIN SPRING CATCH
MK IV-69	MAGAZINE CATCH SPRING
MK IV-70	RECOIL SPRING
MK IV-71	JET NOZZLE SPRING
MK IV-72	CYLINDER SPRINGS X 2
MK IV-73	FIRING PIN SPRING
MK IV-74	PLUNGER SPRING
MK IV-75	IMPACT BLOCK SPRING
MK IV-76	IMPACT BLOCK LOCK SPRING
MK IV-77	MAIN SPRING
MK IV-78	SEAR SPRING
MK IV-81	TRIGGER BOW
MK IV-82	HAMMER STRUT
MK IV-85	RECOIL BUFFER
MK IV-86	MAIN SEAL
MK IV-87	HOP-UP BUCKING
MK IV-90	INNER BARREL CLAMP SCREW
MK IV-91	MAIN SEAL CAP SCREW
MK IV-92	BREECH SCREW
MK IV-93	INNER FRAME SCREW
MK IV-94	FRONT SIGHT SCREW
MK IV-95	IMPACT BLOCK STOPPER SCREW
MK IV-96	TRIGGER SCREW
MK IV-97	ROLL PINS X 2
MK IV-99	HOP-UP BALL
MK IV-105	RECOIL BUFFER WASHER
MK IV-176	TRIGGER
MK IV-182	RECOIL SPRING GUIDE ROD
MK IV 400-MK4	SLIDE
MK IV-401	RAIL FRAME

Parts #	Description
MK IV-402	GRIP (LEFT)
MK IV-403	GRIP (RIGHT)
MK IV-404	FRONT SIGHT
MK IV-405	REAR SIGHT
MK IV-406	DELTA HAMMER
MK IV-407	SLIDE RELEASE LEVER
MK IV-408	GRIP SAFETY
MK IV-409	MAGAZINE CATCH
MK IV-410	MAGAZINE CATCH LOCK
MK IV-411	GRIP SCREWS X 4
MK IV-413	RECOIL PLUG
MK IV-416	MAIN SPRING HOUSING
MK IV-417	SAFETY LEVER (LEFT)
MK IV-418	SAFETY LEVER (RIGHT)
MK IV-420	HAMMER PIN
MK IV-422	OUTER BARREL

1911 MARK SERIES MAGAZINE DIAGRAM AND PARTS LIST

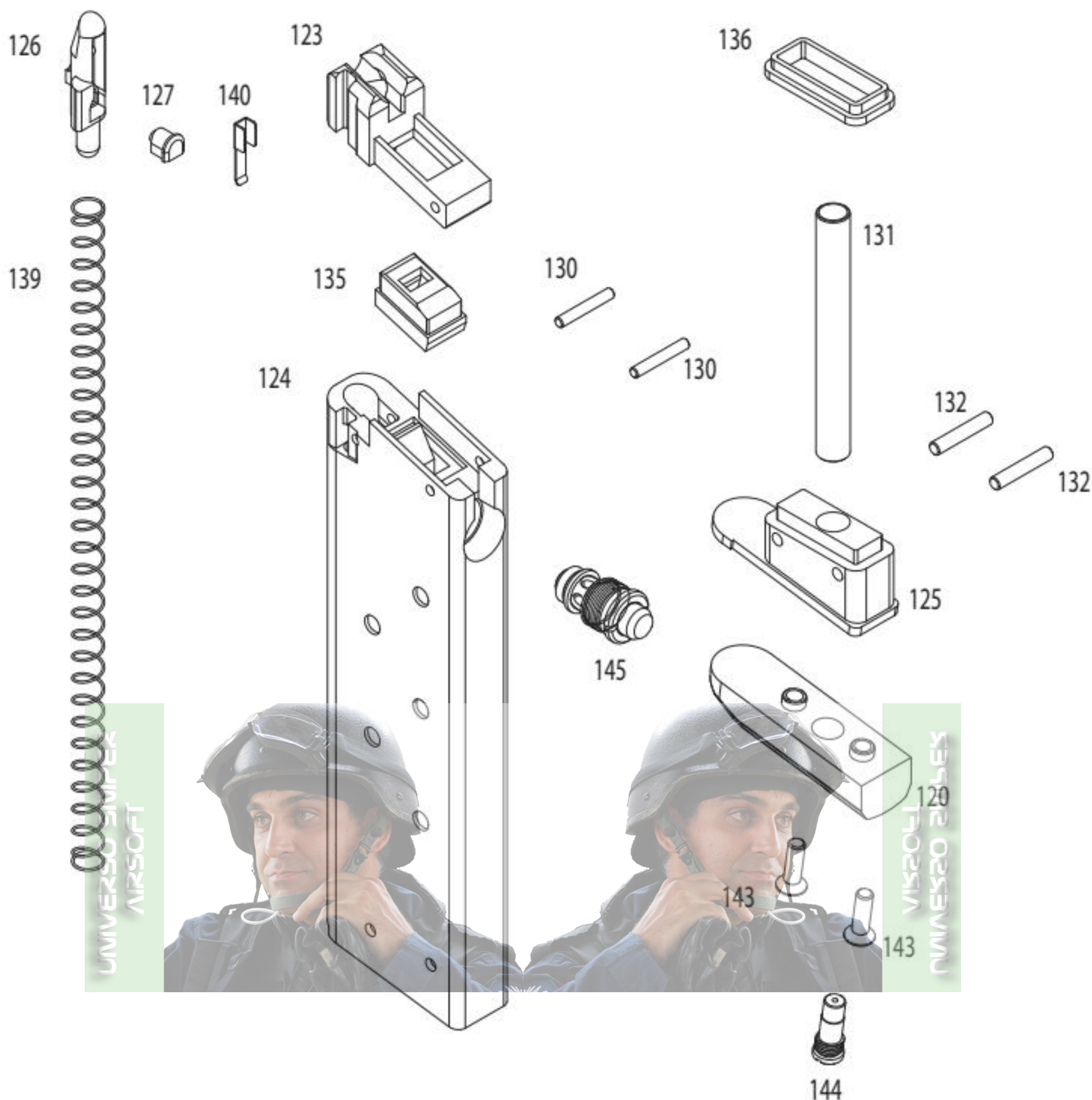

Parts #	Description
1911MK SERIES-120	Magazine Bumper
1911MK SERIES-123	Magazine Lip
1911MK SERIES-124	Magazine Case
1911MK SERIES-125	Magazine Base
1911MK SERIES-126	Magazine Follower
1911MK SERIES-127	Magazine Follower Lock
1911MK SERIES-130	Magazine Lip Pins X 2
1911MK SERIES-131	Magazine Expansion Tube

Parts #	Description
1911MK SERIES-132	Magazine Base Pins X 2
1911MK SERIES-135	Magazine Nozzle Seal
1911MK SERIES-136	Magazine Seal
1911MK SERIES-139	Magazine Follower Spring
1911MK SERIES-140	Magazine Follower Lock Spring
1911MK SERIES-143	Magazine Bumper Screws X 2
1911MK SERIES-144	Magazine Charging Valve
1911MK SERIES-145	Magazine Release Valve



KWA Performance Industries, Inc.

Copyright © June, 2010 KWA Performance Industries, Inc. All Rights Reserved.