

KWA[®]

OPERATOR'S MANUAL

UNIVERSO SNIPER
AIRSOFT



ATP [ADAPTIVE TRAINING PISTOL]

TABLE OF CONTENTS

Use of this manual	2
Safety Guidelines	2-3
Warranty and Service	4-5
Specifications	6
Contents	6
Charging Gas	7
BB Loading	8
Loading Magazine	9
Charging	9
Shooting	9
Open Slide	10
After Shooting	10
Hop-Up System	11
Hop-Up Adjustment Point	12
Disassembly	13
Assembly	14
Troubleshooting	15
General Maintenance	16
Operating Under Unusual Conditions	16
Diagrams and Parts Lists	17-20

USE OF THIS MANUAL

Before operating the Airsoft gun, read this manual in its entirety. Important safety topics and tips are discussed throughout all of the chapters. It's important that the operator know the principles of gun handling safety and operation prior to firing the Airsoft gun.

SAFETY GUIDELINES



WARNING! Failure to follow safety guidelines may result in serious injury.

Safety Distance

The effective shooting range is approximately 75 feet. BBs fired from this Airsoft gun may travel further than intended. Make certain that you have an adequate backstop.

Eye Protection

Eye protection should be worn at all times when both shooting and maintaining your Airsoft gun. Protect your eyes from silicone spray and BBs under spring pressure while performing maintenance on your Airsoft gun.

Assume Every Gun is Always Loaded

Until you are certain the chamber is empty, treat every gun as if it were loaded. Do not assume the chamber is empty based on your memory or someone else's words. Always remove the magazine and visually check to confirm the chamber is empty.

Beware of Barrel Obstructions

Ensure the Airsoft gun barrel is free of obstructions before you fire the gun. Even the smallest obstruction such as lubrication or a stuck cleaning patch can cause a misfire or malfunction.

Muzzle Control

Always keep the muzzle of the gun pointed in a safe direction. Never point the muzzle at a person or object that you do not intend to shoot.

Keep Your Safety On

Keep the gun's safety on until your sights are aligned on your target and you are ready to fire.

Keep Your Finger Off The Trigger

Keep your finger off the trigger and out of the trigger guard until your sights are aligned on your target and you are ready to fire.



WARNING! Airsoft BBs can be a choking hazard. Keep them away from children.

SAFETY GUIDELINES

Identify Your Target and Backstop

Before you pull the trigger, make certain of your target and what is beyond it. The Airsoft gun should never be fired at surfaces such as rocks, glass, water, or other hard surfaces where BBs are likely to ricochet in unpredictable directions.



WARNING! Adult supervision is required for any person under the age of 18.

Failure To Fire

If the Airsoft gun fails to fire, misfires, or malfunctions, do not look into the gun barrel. BBs can become lodged into the chamber, and serious eye injury may occur.

Maintain Your Gun Properly

Performing proper maintenance, as outlined in this manual, ensures that your Airsoft gun will be safe to shoot and will perform to its designed specifications for many years. Alterations, modifications or adjustments may damage your Airsoft gun, make it unsafe to shoot, and will void all warranty claims.

Store Your Gun Safely

Always store the Airsoft gun in a safe place, and out of the reach of children. Always transport the Airsoft gun in a carrying case. Never display the Airsoft gun in a public place. Keep the safety engaged, and remove the magazine before storing the Airsoft gun. Note: it is your responsibility to take every reasonable precaution to ensure the safe storage and transportation of your Airsoft gun.

Orange Tip

The orange tip on Airsoft guns helps Law Enforcement distinguish between the replica guns from their real firearm counterparts. Altering the coloration or markings required by state or Federal law so as to make the product look more like a firearm is dangerous and may be a crime. Operator assumes all risks and responsibility when doing so.

Hazards of Being Mistaken for a Real Firearm

Airsoft guns have been mistaken by Police and Law Enforcement as real firearms. A confrontation with law enforcement while carrying an Airsoft gun can result in serious injury or even death. It is strongly advised to operate the Airsoft gun at a safe and legal location. In the event that you are approached by Law Enforcement personnel, you must comply with their instructions immediately to avoid an incident.

Alcohol, Medications and Drugs

Do not handle or operate your Airsoft gun while under the influence of alcohol, medication or drugs.

Your Responsibility

Your Airsoft gun is well-engineered and manufactured to the highest standards. It was carefully inspected before it was packaged and shipped from our factory. Its safe use depends on you alone. You are the ultimate safety device. Like many other devices, your Airsoft gun is safe unless handled in an irresponsible or uneducated manner.

WARRANTY AND SERVICE

KWA Performance Industries, Inc. is committed to serve our customers with the finest quality products, the highest level of service, and customer satisfaction. Because of this, we offer a 45-day warranty on all KWA products we import and distribute.

What is Covered

Except as specified below, this warranty covers all defects in material and workmanship in KWA products occurring during the above warranty periods. The following are not covered by the warranty: (1) Any product which is not imported and distributed in the U.S.A. by KWA PERFORMANCE INDUSTRIES, INC. (2) Any products not purchased in the U.S.A. from an KWA AUTHORIZED RESELLER (Note: KWA AUTHORIZED RESELLER can be identified by KWA AUTHORIZED RESELLER sticker displayed in the store. If you are uncertain as to whether a dealer is a KWA AUTHORIZED RESELLER, please contact KWA PERFORMANCE INDUSTRIES, INC. as listed above). (3) Damaged deterioration or malfunction resulting from: a) Accident, act of nature, abuse, misuse, neglect, unauthorized product repair, opening of or modification or failure to follow instructions supplied with the product. b) Repair or attempted repair by anyone not authorized by KWA PERFORMANCE INDUSTRIES, INC. c) Removal of the orange safety tip. (4) Use of the product outside the U.S.A. (5) Damaged batteries or improper use of bullets (BBs), or non approved propellants (i.e. Propane, Red Gas, 134a...etc.) (6) Use in industrial, commercial, and/or professional applications.

What KWA Will Pay For

If during the applicable warranty period from the date of the original purchase your KWA product is found to be defective by KWA Performance Industries, Inc., KWA Performance Industries, Inc. will repair, or at its option, replace with new, used, or equivalent model, the defective product without charge for parts or labor.

How To Obtain Warranty Service

If your product needs service, it may be taken or shipped to KWA Performance Industries, Inc. The following procedures apply whenever your unit must be transported for warranty service:

- You must go to the Help Desk at www.kwausa.com/support to obtain an RMA number. THE RMA NUMBER MUST BE CLEARLY MARKED ON THE OUTSIDE OF THE PACKAGE. PACKAGES WITHOUT AN RMA NUMBER CLEARLY MARKED WILL BE REFUSED AND RETURNED TO THE SENDER. NO EXCEPTIONS.
- You are responsible for transporting your unit or arranging for its transportation.
- If shipment of your unit is required; you must pay the initial shipping fee, but we will pay the return shipping charge if the repairs are covered by the warranty.
- WHEN RETURNING YOUR UNIT FOR WARRANTY SERVICE, A COPY OF THE ORIGINAL SALES RECEIPT MUST BE ATTACHED.
- You must include the following: RMA number, your name, address, daytime telephone number, model and serial number (if applicable) of the product and a description of the problem.

This Warranty is Only Valid in the United States

If your product does not require service, but you have questions regarding its operation, please contact our Technical Services Department as listed below.

THIS WARRANTY IS EXPRESSLY MADE IN LIEU OF ALL OTHER WARRANTIES, EXPRESSED OR IMPLIED, INCLUDING WITHOUT LIMITATION, WARRANTIES OF MERCHANTABILITY AND FITNESS FOR A PARTICULAR PURPOSE.

OUR LIABILITY IS LIMITED TO THE REPAIR OR REPLACEMENT, AT OUR OPTION, OF ANY DEFECTIVE PRODUCT AND SHALL IN NO EVENT INCLUDE INCIDENTAL OR CONSEQUENTIAL COMMERCIAL OR PROPERTY DAMAGES OF ANY KIND. WE ARE NOT RESPONSIBLE FOR PRODUCTS LOST, STOLEN AND/OR DAMAGED DURING SHIPPING.

SOME STATES DO NOT ALLOW LIMITATIONS ON HOW LONG AND IMPLIED WARRANTY LASTS AND/OR DO NOT ALLOW THE EXCLUSION OF INCIDENTAL OR CONSEQUENTIAL DAMAGES, THE ABOVE LIMITATIONS AND EXCLUSIONS MAY NOT APPLY TO YOU.

This warranty gives you specific legal rights, but you may also have other rights which vary from state to state. This Warranty may not be altered other than in writing signed by an officer of KWA Performance Industries, Inc.

KWA Performance Industries, Inc.
18571 E. Gale Ave.
City of Industry, CA 91748-1339

626-581-1777

www.kwausa.com

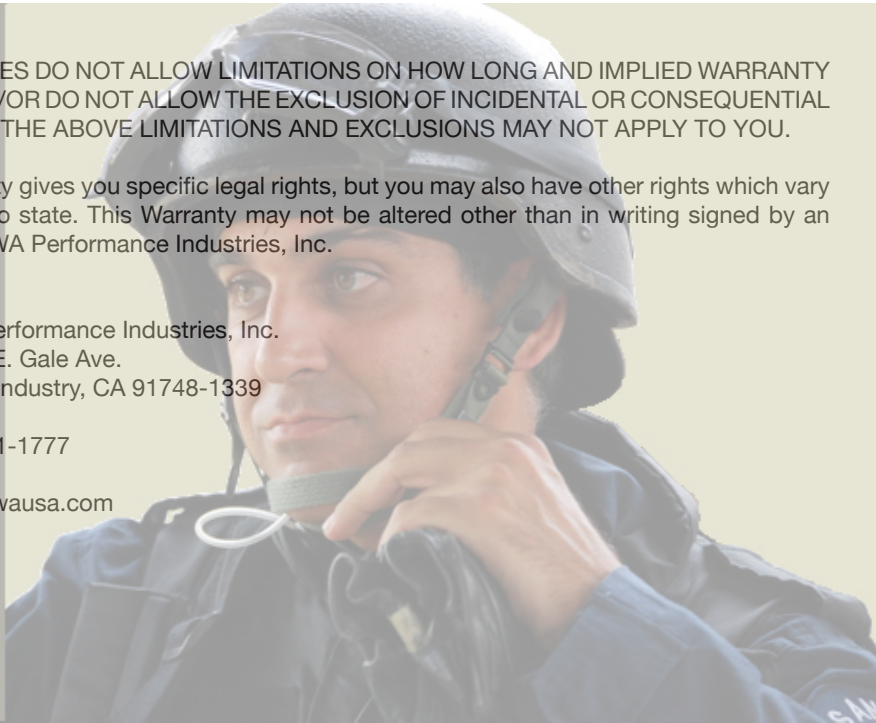

UNIVERSO AIRSOFT

SPECIFICATIONS

- Slide Material = Metal Alloy
- Frame Material = Composite Polymer
- Outer Barrel = Metal Alloy
- Hop-Up = Adjustable
- Action = Single Action
- Propellant = Green Gas
- Overall Length = 20.5 cm (8.07")
- Overall Height = 14.5 cm (5.71")
- Inner Barrel Length = 94 mm
- Inner Barrel Diameter = 6.05 mm
- Weight = 0.70 kg (1.54 lbs)
- Caliber = 6 mm
- Magazine Capacity = 23 rounds
- Velocity = 104-107 MPS (340-350 FPS)
- Energy Output with .20g BB = 1.07 Joules
- Gas System = NS2
- Available Colors = Black only

*Individual test results may vary depending on brand of BBs, type of gas, and chronograph used.

Product Package Contents

- | | |
|--------------------------|-----------------------------|
| 1 ATP Airsoft gun | 1 Sample bag of Airsoft BBs |
| 1 Bottle of Silicone Oil | 1 Hop-Up Adjustment Tool |
| 1 Hi-Cap Magazine | 1 Operator's Manual |

Special Features:

- Adjustable Hop-Up
- Realistic construction and field stripping
- Interchangeable back strap
- Extended slide release
- Front / Rear slide serrations
- 3-dot combat sights



CHARGING GAS

1. Release the magazine by pressing the magazine release button.
2. Hold the magazine up side down. Release the base plate lock, then gently push the base plate forward to reveal the charging valve.
3. Push the gas canister nozzle into the charging valve. Make sure the canister is in a vertical position when charging.
4. Charge the magazine for approximately 10-15 seconds.

Note: It is normal to have minor leaking from the charging valve during charging due to high pressure built up inside the magazine. It is recommended to keep the gas release valve slightly oiled. Room temperature is the ideal temperature for shooting. You may experience a delayed action if the surrounding temperature drops below 68° F.

Note: Do not expose the magazine to direct sunlight or incinerate the magazine, as this may cause the magazine to burst. It is strongly recommended to empty the gas from the magazine after shooting. Be certain that the gas does not make contact with eyes or skin while being released, as any contact will cause cold burns.

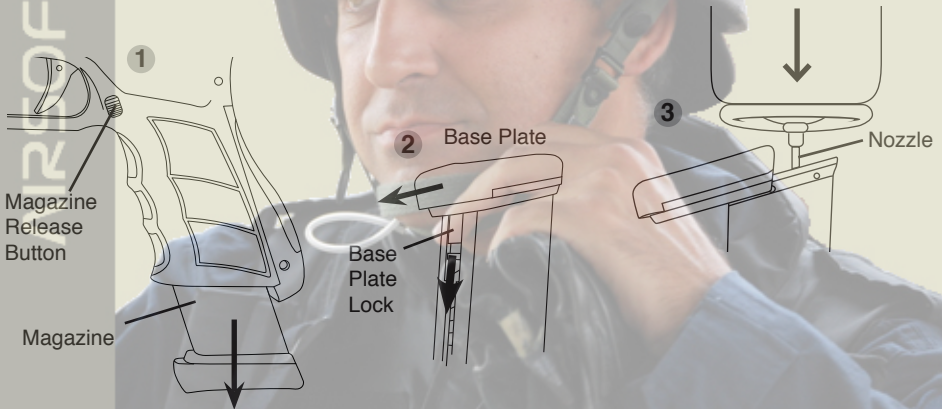

WARNING: Sudden impact with a hard surface may cause damage to the magazine.

Green Gas safety tips:

- Check the canister for any cracks or leaks before using.
- Do not expose the canister to temperature over 104° F.
- Do not leave the canister directly over fire.
- Do not heat the canister.
- Keep the canister away from direct sunlight.
- Do not leave the canister in any type of vehicle.

LOADING BBs

1. Pull the magazine follower down until it locks.
2. Insert BBs into the magazine lip.
3. BBs should stack staggered for maximum round capacity: 23 rounds.
4. Make sure to have a 3mm clearance between BBs and the top lip of the magazine.
5. Push the magazine follower lock to release.

Note: Always use KWA Perfect BBs, size 0.2 or 0.25g. Using only KWA Perfect BBs can give your Airsoft gun its best performance. Using recycled and low grade BBs may damage the gun.



WARNING: Do not release the magazine follower when the magazine is empty. Doing so will damage the magazine and magazine follower.

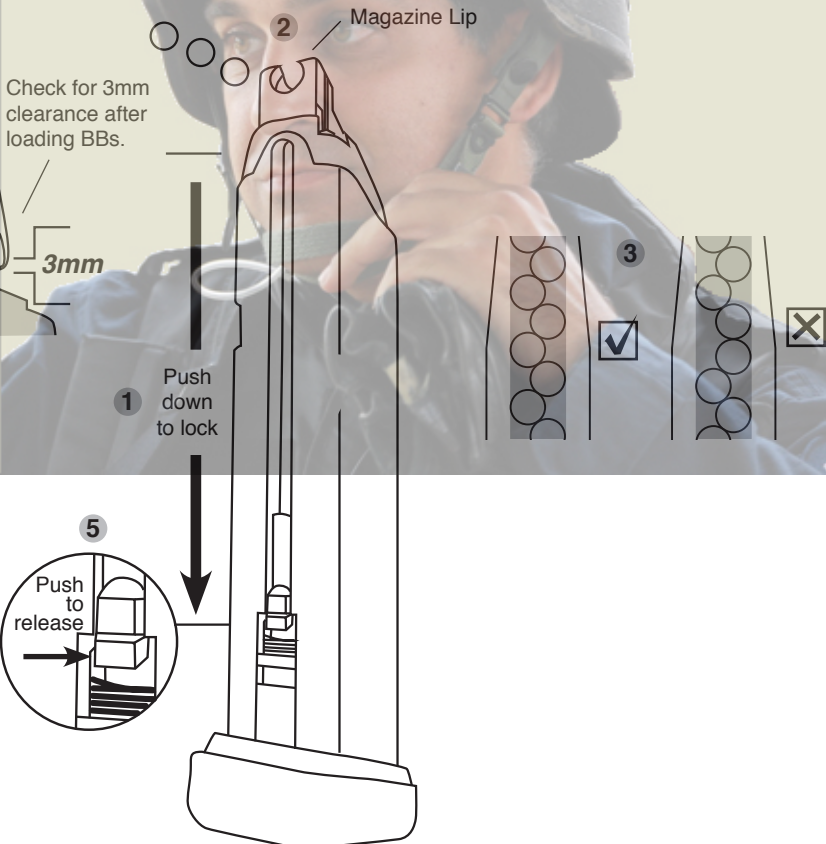

LOADING MAGAZINE

1. Place the magazine back into the magazine well.
2. Push the magazine up until it clicks into a locked position.
3. Pull the magazine down to assure that it has been locked in place.

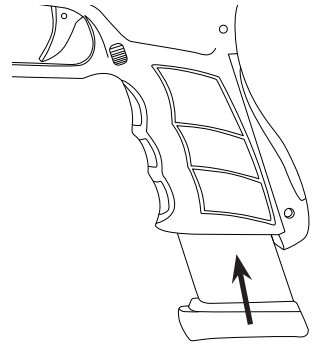

CHARGING

Pull the slide to the rear-most position and release the slide. This will automatically load a BB into the chamber. The hammer will be in a cocked position. Make sure not to skip this procedure. Skipping this step will cause a misfire on the first pull of the trigger. The slide will stay open when the last BB is fired and ejected.

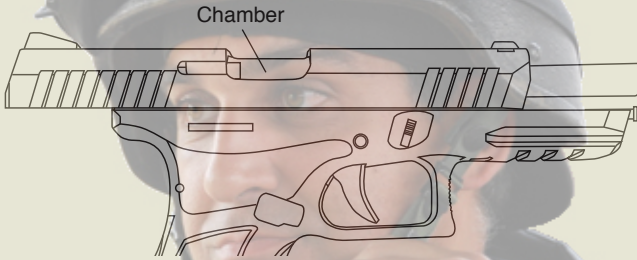

SHOOTING

1. Grasp the Airsoft gun firmly in your hand. To properly control the gun, grasp it with a two-hand hold with one hand wrapped around the other.
2. Pull the trigger. The blow-back action will load the BBs automatically as the slide cycles back and forth.



WARNING: Never shoot gun in a horizontal or upside-down position.

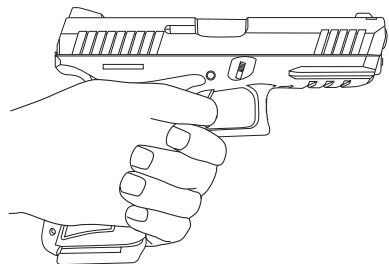
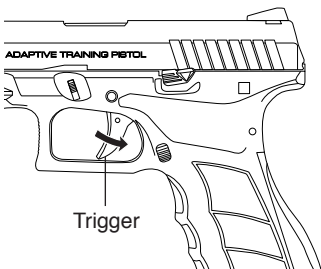

OPEN SLIDE

The slide will remain open after the last BB has been fired and ejected. Remove the empty magazine and replace it with a loaded magazine, then release the slide stop. The first BB will be automatically loaded into the chamber.

Note: It is important to treat your gun as if it were loaded even when the slide is open.

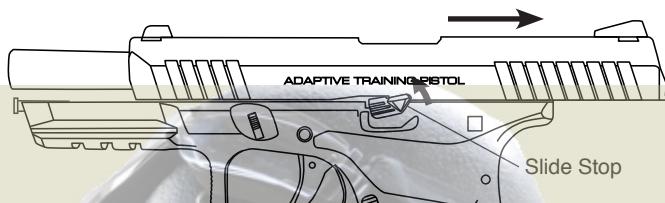

AFTER SHOOTING

After you are finished shooting, remove the magazine and visually examine the open chamber to check for clearance. Make sure both the magazine and the chamber are clear without BBs.

CHECK
Make sure
chamber is clear

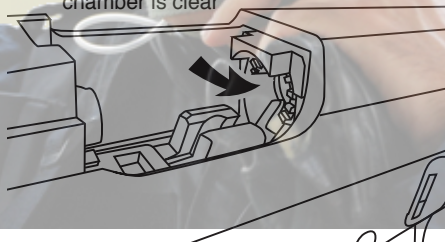

HOP-UP SYSTEM

The Hop-Up device is one of KWA's standard features, giving Airsoft BBs greater stability, further travel and increased accuracy. Airsoft BBs are light-weight and can be affected by wind when fired. With the Hop-Up system, the trajectory of the Airsoft BBs can be adjusted according to the shooting environment or surroundings.











HOP-UP ADJUSTMENT

To adjust the Hop-Up, make sure the magazine is loaded and that you have at least 65 feet of clearance for a test fire before making any adjustments.

1. Test fire the gun for 10 to 20 rounds and observe the BB's traveling pattern.
2. Remove the magazine.
3. Open the slide and place adjusting tool into the slotted chamber ring. Turn the adjusting ring a 1/4-inch at a time.
4. If the BBs are dropping too quickly, move the adjusting ring to the left or counter-clockwise to give the BB more hop. If the BBs are dropping too slowly, move the adjusting ring to the right or clock-wise.
5. Test fire and adjust as needed.



HOP-UP ADJUSTMENT POINT

HOP UP EFFECTIVENESS	BB TRAJECTORY PATTERN	ADJUSTMENTS
<p>NOT EFFECTIVE</p> <p>↑</p> <p>SLIGHTLY</p> <p>PROPERLY</p> <p>OVERLY</p> <p>↓</p> <p>EXTREMELY EFFECTIVE</p>	 <p>BB DROPS FREELY</p>	 <p>TURN KNOB TO LEFT</p>
	 <p>BB TRAVELS AT SHORT TRAJECTORY PATH</p>	 <p>TURN KNOB SLIGHTLY TO LEFT</p>
	 <p>BB TRAVELS DISTANCE AT FLAT TRAJECTORY PATH</p>	 <p>NO ADJUSTMENT MADE</p>
	 <p>BB TRAVELS FLAT IN SHORT DISTANCE, THEN GOES UP IN CURVE AND DROPS FREELY</p>	 <p>TURN KNOB SLIGHTLY TO RIGHT</p>
	 <p>BB TRAVELS AT UNSTABLE SPEED AND IRREGULAR PATH</p>	 <p>TURN KNOB TO RIGHT</p>

UNIVERSO SNIPER
AIRSOFT



DISASSEMBLY

It is not recommended to disassemble the gun unless for general maintenance, or to clear BBs jammed inside the barrel.

1. Remove the magazine by depressing the magazine releases button.
2. Pull the slide to the rear-most position. Push the slide stop upward to hold the slide in position. Check and clear the chamber of BBs.
3. Push the take-down lever downward from both sides of the frame.
4. While the take-down lever is lowered, pull slide backward to release the slide stop then push the slide forward slowly away from the frame. The recoil spring and guide rod will pop loose.
5. Remove the guide rod and spring.
6. Slide the barrel out from underneath the slide.



Magazine Release Button

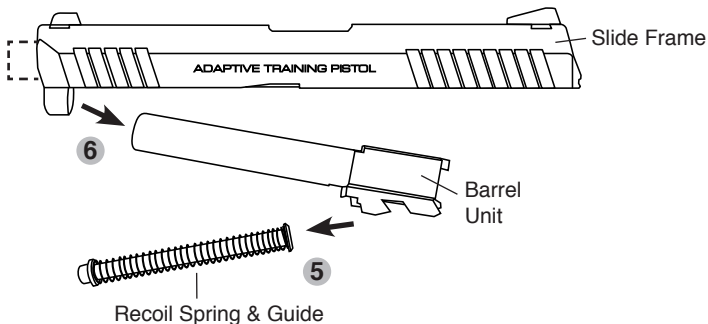
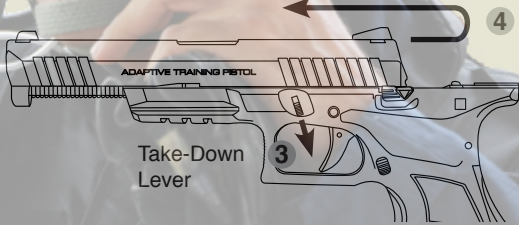

Barrel Unit

Recoil Spring & Guide

ASSEMBLY

1. Make sure the hammer is in the down position.
2. Place the barrel into the slide.
3. Install the recoil spring and guide rod into position.
4. Keep pressure on the spring and guide. Put the assembled slide onto the frame rails and glide it toward the rear of the gun.
5. Pull the slide to rear most position and then release.

NOTE: After assembly is completed, cycle the slide back and forth to insure proper assembly.

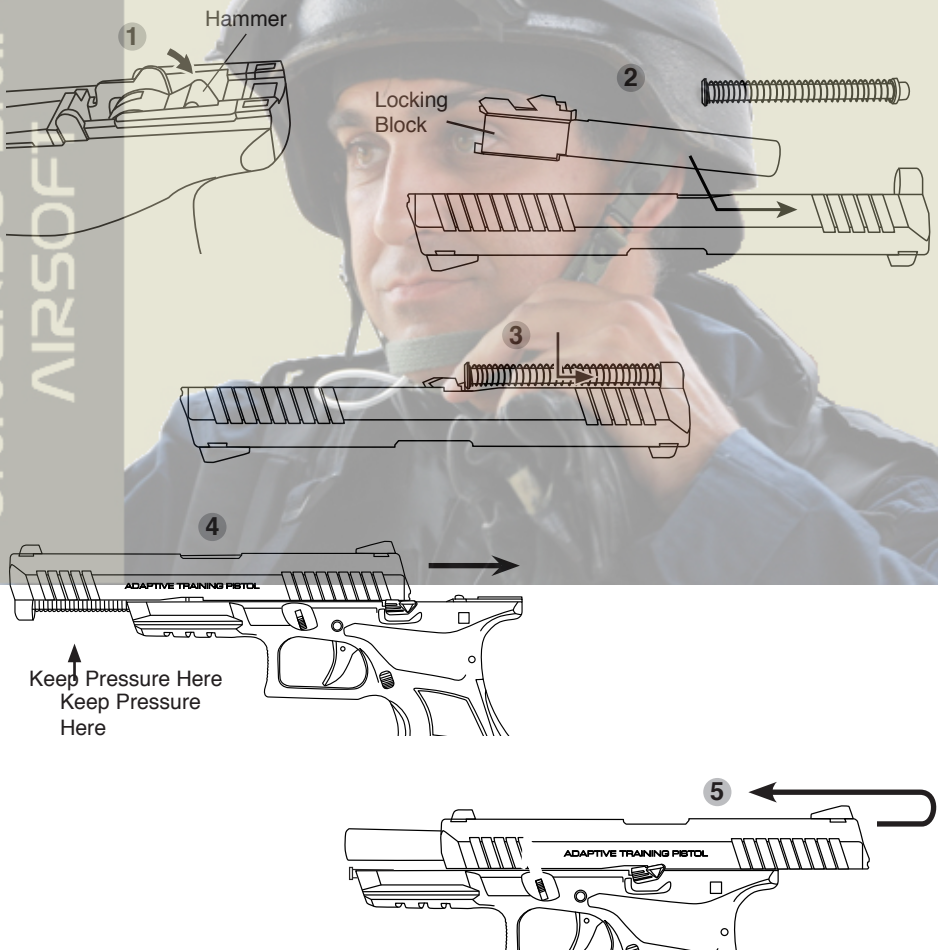

BASIC TROUBLESHOOTING GUIDE FOR PISTOL

SYMPTOMS	POSSIBLE CAUSE	SOLUTIONS
Slide jams / Will not complete cycle	Dry internal	Add silicone to cylinder / main seal / rails
Double feeds BBs into chamber / BB's roll out of barrel	Hop-up adjustment too tight	Release hop-up or replace bucking
BBs will not release from magazine / bent mag lip/ check bb condition	Bent magazine lip	Replace magazine lip
Leaking release valve & charging valve	Dry O-ring	Add silicone oil to valves
Slide stop engages while shooting BBs	Weak slide stop spring	Adjust tension
Magazine base plate will not lock	Broken base plate lock	Replace base plate lock
Magazine base leaking air	Worn out base seal	Replace magazine base seal
Cylinder will not load BBs into chamber	Broken cylinder tap	Replace cylinder
Trigger will not reset	Worn out trigger spring / trigger bar spring	Replace trigger spring / trigger bar spring

UNIVERSO SNIPER
AIRSOFT



GENERAL MAINTENANCE FOR KWA GAS BLOW BACK

Green gas is a liquid propellant which tends to dry out the seals and o-rings. With lubricating silicone oil, it will extend the life of the seals and o-rings and prevent gas leaks.

Use only the recommended 100% silicone oil, available for purchase at the Airsoft dealer where you purchased your KWA products. Any other type of lubricant may damage the products.

Lightly lubricate the recoil spring, cylinder and moving parts with a few drops of oil. Lubricating the seals and o-rings are essential. Unload BBs from the magazine. Make sure the magazine is free of gas before lubricating the magazine's charging valve and release valve.

OPERATING UNDER UNUSUAL CONDITIONS

Unusual conditions are defined as any condition requiring special maintenance. Perform maintenance outlined for the climate similar to your operational area.

Extreme Cold:

Operating an Airsoft gas gun in extremely cold temperatures is not recommended. Cold temperatures will cause the Hop-up Bucking to harden, reducing its effectiveness. Gas will not expand properly in cold temperatures, so both the cycling rate and power will be dramatically reduced.

Extreme Heat:

Operating an Airsoft gas gun in extremely hot temperatures is also not recommended. Leaving the gun in direct sunlight for long periods of time, or operating in extremely hot areas will cause the gas to over-expand, damaging the internal workings of the gun. The increase in internal pressure from the expanding gas can also damage the seals and cause leaks in the magazine.

Dust or Sand:

Dust or sand can get into a gas gun and cause malfunctions and/or excessive wear. Keep the gun covered whenever possible. Use lubricant sparingly, as lube naturally attracts dirt and other particles. After use in a dusty area, always field strip the gun (refer to Disassembly Section) and clean any areas you can reach with a soft, lint-free cloth.

PARTS DIAGRAM

UNIVERSO SNIPER
AIRSOFT

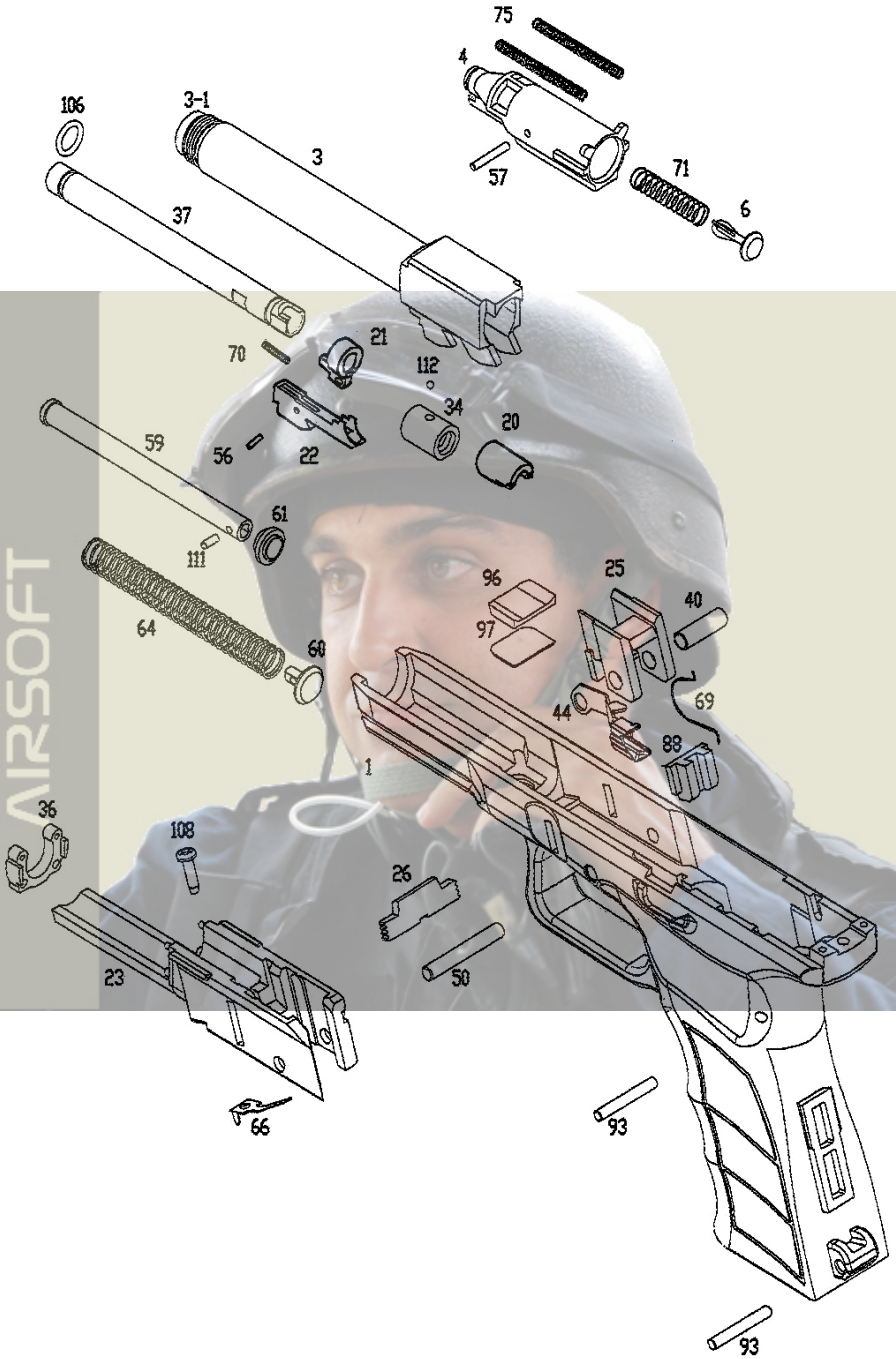

UNIVERSO SNIPER
AIRSOFT

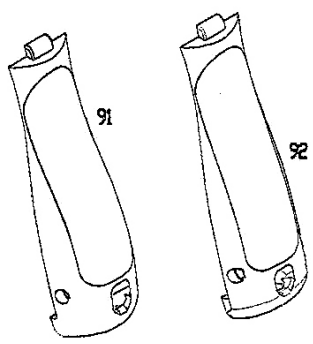
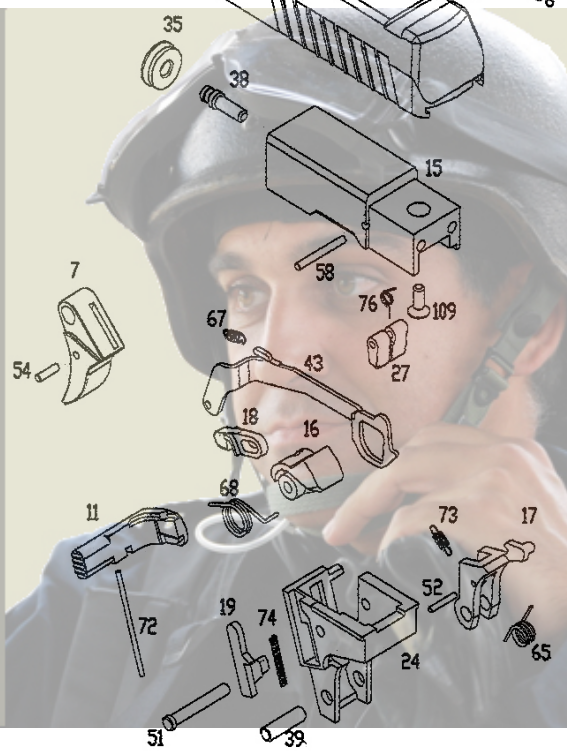
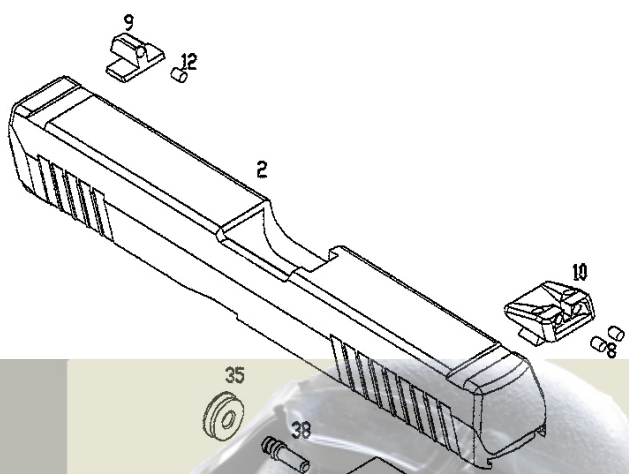

PARTS LIST

Parts #	Description	Parts #	Description	Parts #	Description
199-0102-1	FRAME	199-0102-37	INNER BARREL	199-0102-76	HAMMER RESET SPRING
199-0102-2	SLIDE	199-0102-38	PISTON PIN	199-0102-88	TRIGGER BACK
199-0102-3	OUTER BARREL	199-0102-39	SEAR PIN	199-0102-91	BACK STRAP (B)
199-0102-3~1	THREADED OUTER BARREL	199-0102-40	TRIGGER PIN	199-0102-92	BACK STRAP (A)
199-0102-4	GAS CHAMBER CYLINDER	199-0102-43	TRIGGER TRANSFER BAR	199-0102-93	BACK STRAP PIN X 2
199-0102-6	JET NOZZLE	199-0102-44	SLIDE STOP LEVER	199-0102-96	SERIAL PLATE STOP
199-0102-7	TRIGGER	199-0102-50	TRIGGER BLOCK PIN	199-0102-97	SERIAL PLATE
199-0102-8	REAR SIGHT INSERT X 2	199-0102-51	HAMMER PIN	199-0102-106	INNER BARREL O-RING
199-0102-9	FRONT SIGHT	199-0102-52	IMPACT BLOCK PIN	199-0102-108	INNER FRAME SCREW
199-0102-10	REAR SIGHT	199-0102-54	TRIGGER TRANSFER PIN	199-0102-109	BREECH SCREW
199-0102-11	MAGAZINE CATCH	199-0102-56	FEED RAMP PIN	199-0102-111	RECOIL SPRING GUIDE PIN
199-0102-12	FRONT SIGHT INSERT	199-0102-57	JET NOZZLE PIN	199-0102-112	HOP-UP BALL
199-0102-15	BREECH	199-0102-58	HAMMER RESET PIN		
199-0102-16	HAMMER	199-0102-59	RECOIL SPRING GUIDE BODY		
199-0102-17	SEAR	199-0102-60	RECOIL SPRING GUIDE STOP		
199-0102-18	IMPACT BLOCK	199-0102-61	RECOIL SPRING GUIDE BUSHING		
199-0102-19	IMPACT BLOCK RESET	199-0102-64	RECOIL SPRING		
199-0102-20	HOPUP ADJUSTMENT HOOD	199-0102-65	SEAR SPRING		
199-0102-21	INNER BARREL SLEEVE	199-0102-66	TAKEDOWN LEVER SPRING		
199-0102-22	FEED RAMP	199-0102-67	TRIGGER RESET SPRING		
199-0102-23	INNER FRAME	199-0102-68	HAMMER SPRING		
199-0102-24	HAMMER BLOCK	199-0102-69	SLIDE STOP SPRING		
199-0102-25	TRIGGER BLOCK	199-0102-70	INNER BARREL SPRING		
199-0102-26	TAKEDOWN LEVER	199-0102-71	JET NOZZLE SPRING		
199-0102-27	HAMMER RESET LEVER	199-0102-72	MAGAZINE CATCH SPRING		
199-0102-34	HOP-UP BUCKING	199-0102-73	IMPACT BLOCK RETURN SPRING		
199-0102-35	PISTON SEAL	199-0102-74	IMPACT BLOCK RESET SPRING		
199-0102-36	RECOIL BUFFER	199-0102-75	CYLINDER RETURN SPRING X 2		

MAGAZINE DIAGRAM AND PARTS LIST

UNIVERSO SNIPER
AIRSOFT

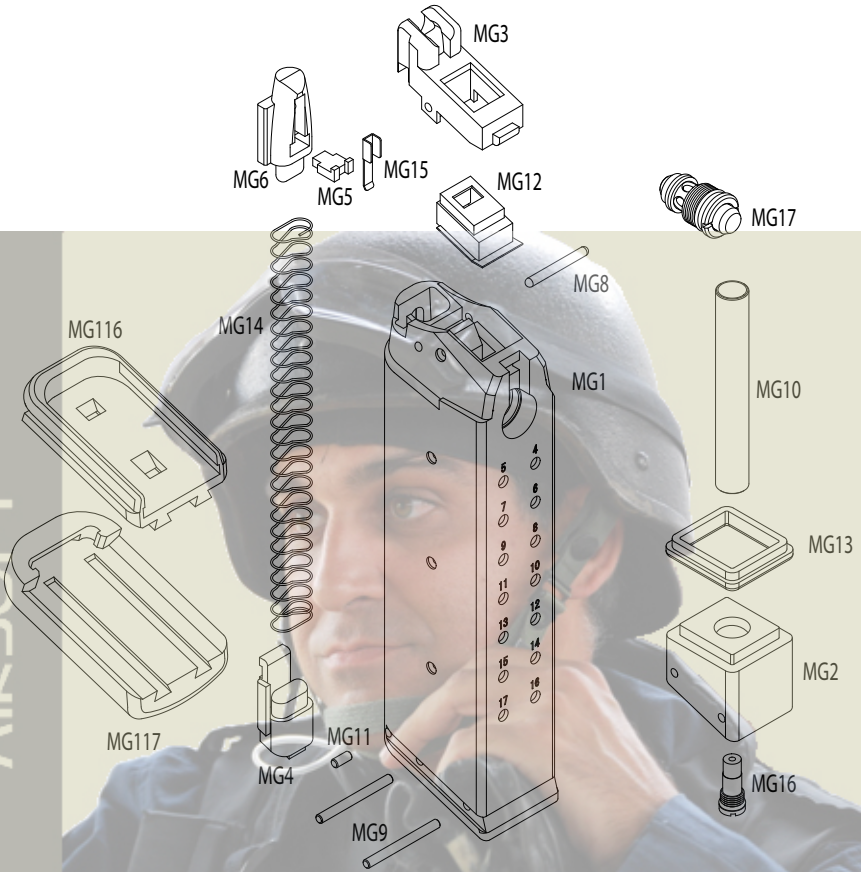

Parts #	Description
199-0102-MG1	MAGAZINE BODY
199-0102-MG2	MAGAZINE BASE
199-0102-MG3	MAGAZINE LIP
199-0102-MG4	MAGAZINE BASE PLATE LOCK
199-0102-MG5	MAGAZINE FOLLOWER LOCK
199-0102-MG6	MAGAZINE FOLLOWER
199-0102-MG8	MAGAZINE LIP PIN
199-0102-MG9	MAGAZINE INNER BASE PINS X 2
199-0102-MG10	MAGAZINE EXPANSION TUBE

Parts #	Description
199-0102-MG11	MAGAZINE BASE PLATE LOCK PIN
199-0102-MG12	MAGAZINE NOZZLE SEAL
199-0102-MG13	MAGAZINE BASE SEAL
199-0102-MG14	MAGAZINE SPRING
199-0102-MG15	MAGAZINE FOLLOWER LOCK SPRING
199-0102-MG16	MAGAZINE CHARGING VALVE
199-0102-MG17	MAGAZINE RELEASE VALVE
199-0102-MG116	MAGAZINE BASE PLATE
199-0102-MG117	MAGAZINE BASE PLATE BUMPER

UNIVERSO SNIPER
AIRSOFT



KWA Performance Industries, Inc.

18571 E. Gale Ave

City of Industry, CA 91748

T: 626.581.1777 • F: 626.581.0777

www.kwausa.com