

KWA®

OPERATOR'S MANUAL

UNIVERSO SNIPER
AIRSOFT



M11A1 NS2

TABLE OF CONTENTS

Use of this Manual	3
Safety Guidelines	3-4
Warranty and Service	5-6
Specifications	7
Contents	8
Functions and Features	8
Charging Gas	9
Loading BBs	10
Locking Bolt	11
Loading Magazine	11
Selector	12
Safety	12
Retractable Stock	13
Shooting	13
Open Bolt	14
After Shooting	14
Hop-Up System	15
Adjustment Point	16
Disassembly	17-18
Assembly	19
Troubleshooting	20
General Maintenance	21
Operating Under Unusual Conditions	22
Diagrams and Parts Lists	23-26

USE OF THIS MANUAL

Before operating the Airsoft gun, read this manual in its entirety. Important safety topics and tips are discussed throughout all of the chapters. It's important that the operator know the principles of gun handling safety and operation prior to firing the Airsoft gun.

SAFETY GUIDELINES



WARNING! Failure to follow safety guidelines may result in serious injury.

Safety Distance

The effective shooting range is approximately 75 feet. BBs fired from this Airsoft gun may travel further than intended. Make certain that you have an adequate backstop.

Eye Protection

Eye protection should be worn at all times when both shooting and maintaining your Airsoft gun. Protect your eyes from silicone spray and BBs under spring pressure while performing maintenance on your Airsoft gun.

Assume Every Gun is Always Loaded

Until you are certain the chamber is empty, treat every gun as if it were loaded. Do not assume the chamber is empty based on your memory or someone else's words. Always remove the magazine and visually check to confirm the chamber is empty.

Beware of Barrel Obstructions

Ensure the Airsoft gun barrel is free of obstructions before you fire the gun. Even the smallest obstruction such as lubrication or a stuck cleaning patch can cause a misfire or malfunction.

Muzzle Control

Always keep the muzzle of the gun pointed in a safe direction. Never point the muzzle at a person or object that you do not intend to shoot.

Keep Your Safety On

Keep the gun's safety on until your sights are aligned on your target and you are ready to fire.

Keep Your Finger Off The Trigger

Keep your finger off the trigger and out of the trigger guard until your sights are aligned on your target and you are ready to fire.



WARNING! Airsoft BBs can be a choking hazard. Keep them away from children.

SAFETY GUIDELINES

Identify Your Target and Backstop

Before you pull the trigger, make certain of your target and what is beyond it. The Airsoft gun should never be fired at surfaces such as rocks, glass, water, or other hard surfaces where BBs are likely to ricochet in unpredictable directions.



WARNING! Adult supervision is required for any person under the age of 18.

Failure To Fire

If the Airsoft gun fails to fire, misfires, or malfunctions, do not look into the gun barrel. BBs can become lodged into the chamber, and serious eye injury may occur.

Maintain Your Gun Properly

Performing proper maintenance, as outlined in this manual, ensures that your Airsoft gun will be safe to shoot and will perform to its designed specifications for many years. Alterations, modifications or adjustments may damage your Airsoft gun, make it unsafe to shoot, and will void all warranty claims.

Store Your Gun Safely

Always store the Airsoft gun in a safe place, and out of the reach of children. Always transport the Airsoft gun in a carrying case. Never display the Airsoft gun in a public place. Keep the safety engaged, and remove the magazine before storing the Airsoft gun. Note: it is your responsibility to take every reasonable precaution to ensure the safe storage and transportation of your Airsoft gun.

Orange Tip

The orange tip on Airsoft guns helps Law Enforcement distinguish between the replica guns from their real firearm counterparts. Altering the coloration or markings required by state or Federal law so as to make the product look more like a firearm is dangerous and may be a crime. Operator assumes all risks and responsibility when doing so.

Hazards of Being Mistaken for a Real Firearm

Airsoft guns have been mistaken by Police and Law Enforcement as real firearms. A confrontation with law enforcement while carrying an Airsoft gun can result in serious injury or even death. It is strongly advised to operate the Airsoft gun at a safe and legal location. In the event that you are approached by Law Enforcement personnel, you must comply with their instructions immediately to avoid an incident.

Alcohol, Medications and Drugs

Do not handle or operate your Airsoft gun while under the influence of alcohol, medication or drugs.

Your Responsibility

Your Airsoft gun is well-engineered and manufactured to the highest standards. It was carefully inspected before it was packaged and shipped from our factory. Its safe use depends on you alone. You are the ultimate safety device. Like many other devices, your Airsoft gun is safe unless handled in an irresponsible or uneducated manner.

WARRANTY AND SERVICE

KWA Performance Industries, Inc. is committed to serve our customers with the finest quality products, the highest level of service, and customer satisfaction. Because of this, we offer a 45-day warranty on all KWA products we import and distribute.

What is Covered

Except as specified below, this warranty covers all defects in material and workmanship in KWA products occurring during the above warranty periods. The following are not covered by the warranty: (1) Any product which is not imported and distributed in the U.S.A. by KWA PERFORMANCE INDUSTRIES, INC. (2) Any products not purchased in the U.S.A. from an KWA AUTHORIZED RESELLER (Note: KWA AUTHORIZED RESELLER can be identified by KWA AUTHORIZED RESELLER sticker displayed in the store. If you are uncertain as to whether a dealer is a KWA AUTHORIZED RESELLER, please contact KWA PERFORMANCE INDUSTRIES, INC. as listed above). (3) Damaged deterioration or malfunction resulting from: a) Accident, act of nature, abuse, misuse, neglect, unauthorized product repair, opening of or modification or failure to follow instructions supplied with the product. b) Repair or attempted repair by anyone not authorized by KWA PERFORMANCE INDUSTRIES, INC. c) Removal of the orange safety tip. (4) Use of the product outside the U.S.A. (5) Damaged batteries or improper use of bullets (BBs), or non approved propellants (i.e. Propane, Red Gas, 134a...etc.) (6) Use in industrial, commercial, and/or professional applications.

What KWA Will Pay For

If during the applicable warranty period from the date of the original purchase your KWA product is found to be defective by KWA Performance Industries, Inc., KWA Performance Industries, Inc. will repair, or at its option, replace with new, used, or equivalent model, the defective product without charge for parts or labor.

How To Obtain Warranty Service

If your product needs service, it may be taken or shipped to KWA Performance Industries, Inc. The following procedures apply whenever your unit must be transported for warranty service:

- You must go to Help Desk at www.kwausa.com/support to obtain an RMA number. THE RMA NUMBER MUST BE CLEARLY MARKED ON THE OUTSIDE OF THE PACKAGE. PACKAGES WITHOUT AN RMA NUMBER CLEARLY MARKED WILL BE REFUSED AND RETURNED TO THE SENDER.
- You are responsible for transporting your unit or arranging for its transportation.
- If shipment of your unit is required; you must pay the initial shipping fee, but we will pay the return shipping charge if the repairs are covered by the warranty.
- WHEN RETURNING YOUR UNIT FOR WARRANTY SERVICE, A COPY OF THE ORIGINAL SALES RECEIPT MUST BE ATTACHED.
- You must include the following: RMA number, your name, address, daytime telephone number, model and serial number (if applicable) of the product and a description of the problem.

NOTE: THE RMA NUMBER MUST BE CLEARLY MARKED ON THE OUTSIDE OF THE PACKAGE. PACKAGES WITHOUT AN RMA NUMBER CLEARLY MARKED WILL BE REFUSED AND RETURNED TO SENDER. NO EXCEPTIONS.

This Warranty is Only Valid in the United States

If your product does not require service, but you have questions regarding its operation, please contact our Technical Services Department as listed below.

THIS WARRANTY IS EXPRESSLY MADE IN LIEU OF ALL OTHER WARRANTIES, EXPRESSED OR IMPLIED, INCLUDING WITHOUT LIMITATION, WARRANTIES OF MERCHANTABILITY AND FITNESS FOR A PARTICULAR PURPOSE.

OUR LIABILITY IS LIMITED TO THE REPAIR OR REPLACEMENT, AT OUR OPTION, OF ANY DEFECTIVE PRODUCT AND SHALL IN NO EVENT INCLUDE INCIDENTAL OR CONSEQUENTIAL COMMERCIAL OR PROPERTY DAMAGES OF ANY KIND. WE ARE NOT RESPONSIBLE FOR PRODUCTS LOST, STOLEN AND/OR DAMAGED DURING SHIPPING.

SOME STATES DO NOT ALLOW LIMITATIONS ON HOW LONG AND IMPLIED WARRANTY LASTS AND/OR DO NOT ALLOW THE EXCLUSION OF INCIDENTAL OR CONSEQUENTIAL DAMAGES, THE ABOVE LIMITATIONS AND EXCLUSIONS MAY NOT APPLY TO YOU.

This warranty gives you specific legal rights, but you may also have other rights which vary from state to state. This Warranty may not be altered other than in writing signed by an officer of KWA Performance Industries, Inc.

KWA Performance Industries, Inc.
18571 E. Gale Ave.
City of Industry, CA 91748-1339

626-581-1777
www.kwaua.com

SPECIFICATIONS

- Overall Length [Retracted] = 25.4 cm (10")
- Overall Length [Extended] = 45.5 cm (17.92")
- Overall Height = 25 cm (9.84")
- Inner Barrel Length = 115 mm
- Inner Barrel Diameter = 6.05 mm
- Weight = 1.32 kg
- Caliber = 6 mm
- Magazine Capacity = 48
- Rate of Fire = 20+ RPS
- Velocity = 103-110 MPS (340-360 FPS)
- Energy Output with .20g BB = 1.07 Joules
- Gas System = NS2

Special Features:

- Heavy duty construction with polymer casing
- Functional cocking handle with realistic bolt movements
- Retractable shoulder stock
- Threaded barrel
- Semi and Full Auto selective fire
- Front sling swivel

*Individual test results may vary depending on brand of BBs, type of gas, and chronograph used.

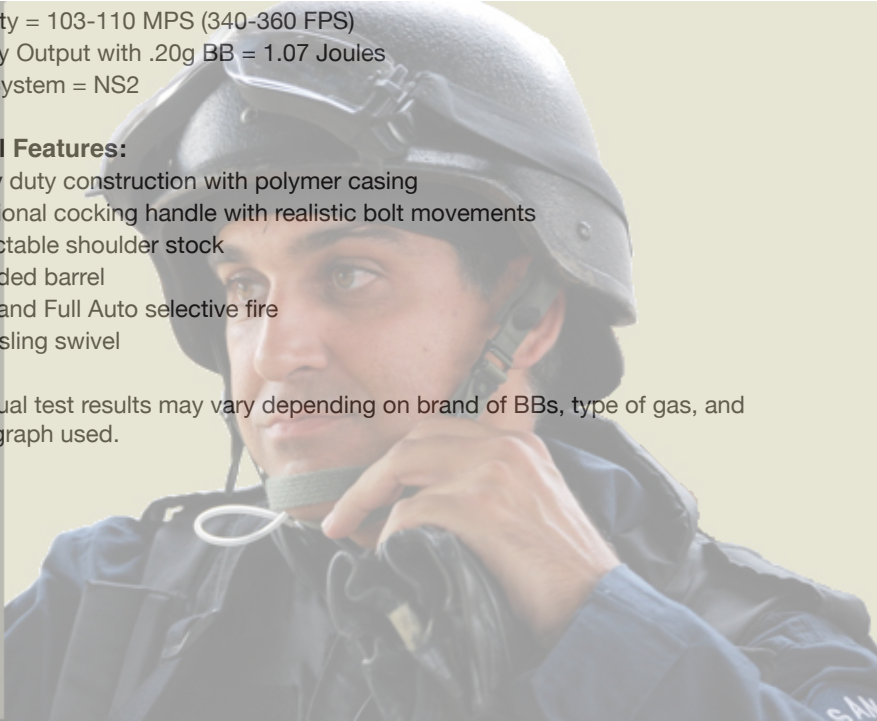

UNIVERSO SNIPERS
AIRSOFT

CONTENTS

Product Package Contents

- 1 M11A1 NS2 Airsoft gun
- 1 Bottle of Silicon Oil
- 1 Hi-Cap Magazine
- 1 Sample Bag of Airsoft BBs
- 1 Hop-Up Adjustment Tool
- 1 Operator's Manual

FUNCTIONS AND FEATURES

M11A1 with NS2 gas system

The popular M11A1 guns are equipped with the new KWA NS2 internal gas delivery system, which increases performance and improves the overall reliability of the gun.

The NS2 gas system is a KWA-patented design that uses an advanced, light-weight composite gas piston with a two-stage internal expansion chamber that delivers the gas more efficiently than that of its predecessors. The NS2 design also increases the weapon cycle rate and provides for a crisp, realistic blow-back action

Other parts of the Airsoft gun, including the recoil springs, recoil spring guide assembly, hop-up chamber, and magazine follower, have been improved, along with a new magazine that is milled from a solid alloy steel billet. This new construction strengthens the magazine's structural integrity and increases pressure carrying capacity. The magazine feed-lip has also been reinforced.

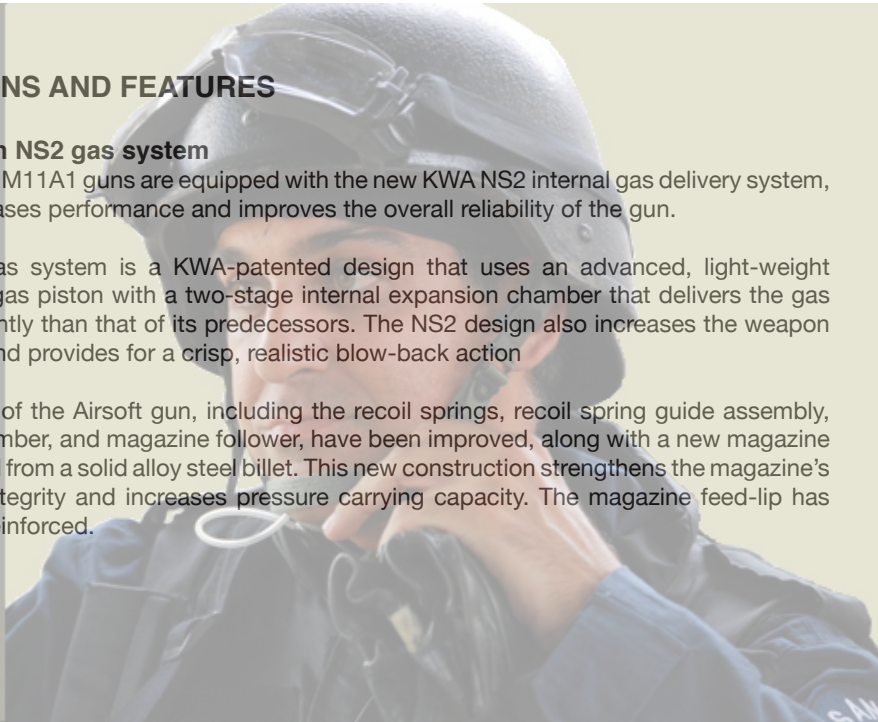

CHARGING GAS

1. Release the magazine by pressing the magazine catch.
2. Push the gas canister nozzle into the charging valve. Make sure the canister is in a vertical position when charging.
3. Charge the magazine until gas overflows from the charging valve.



WARNING: Sudden impact with a hard surface may cause damage to the magazine.

Note: It is normal to have minor leaking from the charging valve during charging due to high pressure built up inside the magazine. It is recommended to keep the gas release valve slightly oiled. Room temperature is the ideal temperature for shooting. You may experience a delayed action if the surrounding temperature drops below 68° F.

Note: Do not expose the magazine to direct sunlight or incinerate the magazine, as this may cause the magazine to burst. It is strongly recommended to empty the gas from the magazine after shooting. Be certain that the gas does not make contact with eyes or skin while being released, as any contact will cause cold burns.



Green Gas safety tips:

- Check the canister for any cracks or leaks before using.
- Do not expose the canister to temperature over 104° F.
- Do not leave the canister directly over fire.
- Do not heat the canister.
- Keep the canister away from direct sunlight.
- Do not leave the canister in any type of vehicle.

LOADING BBS

1. Pull the magazine follower down until it locks.
2. Insert BBs into the magazine lip.
3. BBs should stack staggered for maximum round capacity: 48 rounds.
4. Make sure to have a 3mm clearance between BBs and the top lip of the magazine.
5. Push the magazine follower lock to release.

Note: Always use KWA Perfect BBs, size 0.2 or 0.25g. Using only KWA Perfect BBs can give your Airsoft gun its best performance. Using recycled and low grade BBs may damage the gun.



WARNING: Do not release the magazine follower when the magazine is empty. Doing so will damage the magazine and magazine follower.

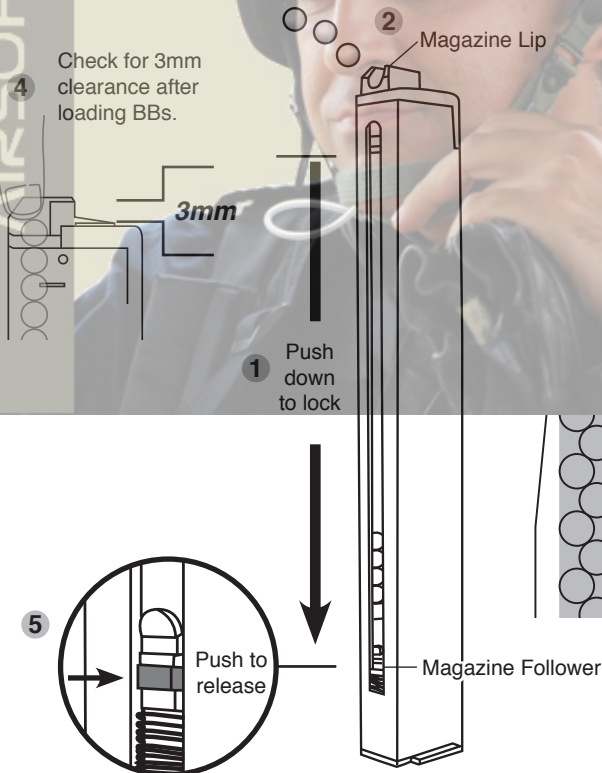

Locking Bolt



WARNING: Before loading the magazine, the bolt must be in lock position. To lock the bolt, pull the bolt handle back to the rear of the gun.

NOTE: For absolute assurance against accidental discharge due to inadvertent trigger pull, keep the manual safety engaged during loading or unloading.

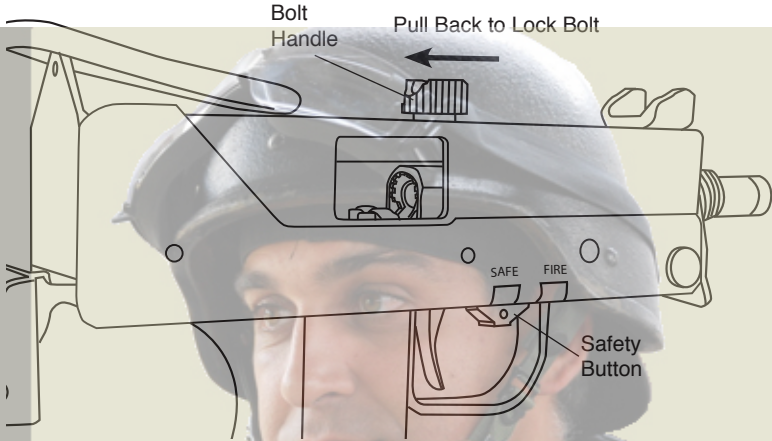

WARNING: Always keep finger off the trigger until ready to fire. Make sure the muzzle is pointing in a safe direction.

LOADING MAGAZINE

Note: Do not insert magazine into the gun when the bolt is closed. Doing so will damage the loading nozzle.

1. Pull the bolt handle back to lock the bolt.
2. Place the magazine back into the magazine well.
3. Push the magazine up until it clicks into a locked position.
4. Pull the magazine down to assure that it has been locked in place.

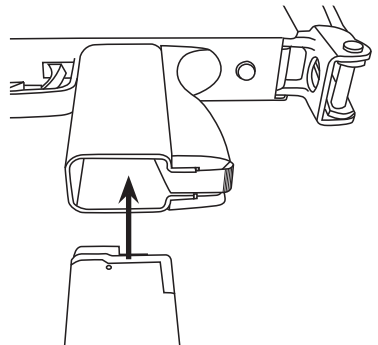

SELECTOR

The selector is located on the left side of the frame. Select (S) to fire semi-automatic (single shot) and select (F) to fire full automatic (continuous fire).

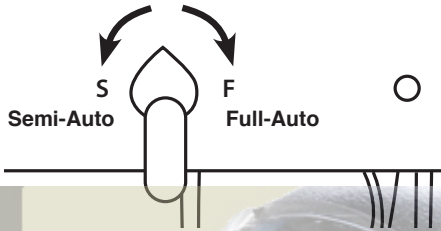

SAFETY

The safety button is located in front of the trigger. Safety is engaged when you push safety button to "SAFE". Safety is disengaged when you push safety button to "FIRE".



When the bolt is closed, bolt can be locked for storage by turning the bolt knob 90° counterclockwise.

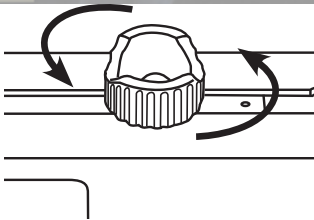

WARNING: Make sure safety is on at all times when not in a shooting position.

RETRACTABLE STOCK

1. Push the wire handles inward.
2. Swing the wire handles downwards until it locks.
3. Press and hold the stock button while pulling the stock slightly outward. Release the stock button.
4. Pull the retractable stock until the stock locks into position.

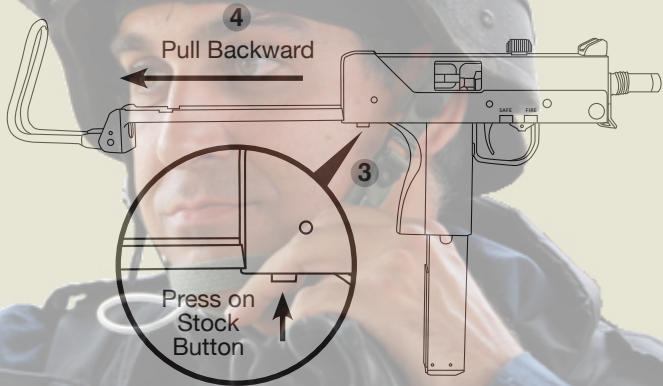
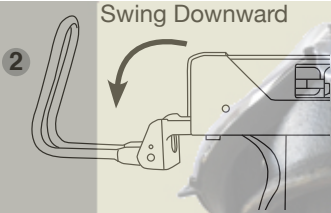
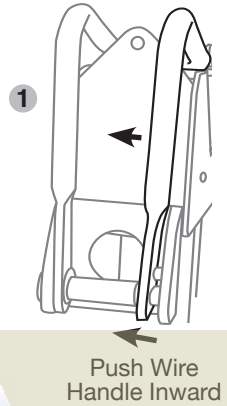

NOTE: To remove the retractable stock from the gun, press and hold the stock button and pull the stock out completely.

SHOOTING

1. Choose shooting mode. Select "S" for semi-auto or "F" for full-auto.
2. Disengage the safety.
3. Pull the trigger to fire.



WARNING: It is recommended eye protection be wore at all times. BBs may bounce off hard surfaces (ricochet). Always point gun in a safe direction.

OPEN BOLT

After the last shot has been fired and ejected. The bolt will lock halfway and the ejection port will remain opened.

NOTE: It is important to treat your gun as though it is loaded, even if the bolt remains open.

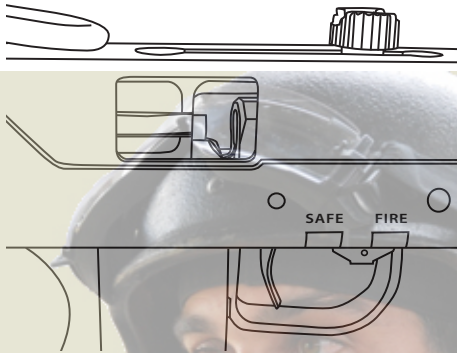

AFTER SHOOTING

Visually inspect the open bolt to check whether the magazine well and chamber are clear of BBs. When both the magazine well and chamber are clear, **ENGAGE SAFETY SWITCH**.

NOTE: Keep the chamber piston and seals oiled lightly with 100% silicone oil after shooting



HOP-UP SYSTEM

The Hop-Up device is one of KWA's standard features, giving Airsoft BBs greater stability, further travel and increased accuracy. Airsoft BBs are light-weight and can be affected by wind when fired. With the Hop-Up system, the trajectory of the Airsoft BBs can be adjusted according to the shooting environment or surroundings.

HOP-UP ADJUSTMENT





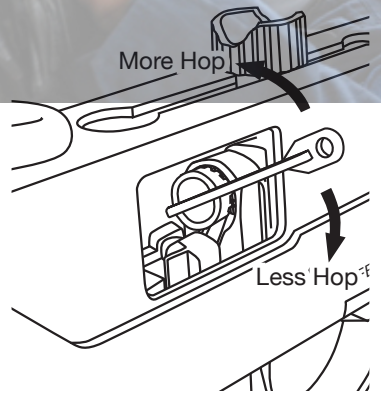
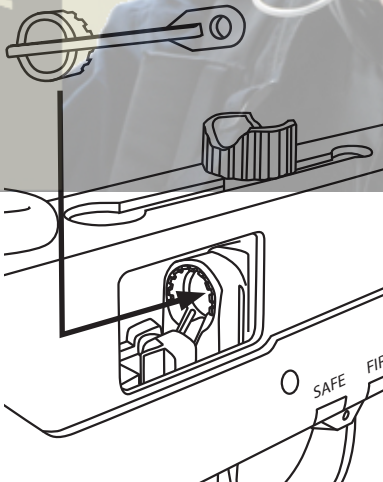





To adjust the Hop-Up, make sure the magazine is loaded and that you have at least 65 feet of clearance for a test fire before making any adjustments.

1. Test fire the gun for 10 to 20 rounds and observe the BB's traveling pattern.
2. Remove the magazine.
3. Open the slide and place adjusting tool into the slotted chamber ring. Turn the adjusting ring a 1/4-inch at a time.
4. If the BBs are dropping too quickly, move the adjusting ring to the left or counter-clockwise to give the BB more hop. If the BBs are dropping too slowly, move the adjusting ring to the right or clock-wise.
5. Test fire and adjust as needed.



UNIVERSO SNIPER
AIRSOFT

ADJUSTMENT POINT

HOP UP EFFECTIVENESS	BB TRAJECTORY PATTERN	ADJUSTMENTS
<p>NOT EFFECTIVE</p> <p>↑</p> <p>SLIGHTLY</p> <p>PROPERLY</p> <p>OVERLY</p> <p>↓</p> <p>EXTREMELY EFFECTIVE</p>	 <p>BB DROPS FREELY</p>	 <p>TURN KNOB TO LEFT</p>
	 <p>BB TRAVELS AT SHORT TRAJECTORY PATH</p>	 <p>TURN KNOB SLIGHTLY TO LEFT</p>
	 <p>BB TRAVELS DISTANCE AT FLAT TRAJECTORY PATH</p>	 <p>NO ADJUSTMENT MADE</p>
	 <p>BB TRAVELS FLAT IN SHORT DISTANCE, THEN GOES UP IN CURVE AND DROPS FREELY</p>	 <p>TURN KNOB SLIGHTLY TO RIGHT</p>
	 <p>BB TRAVELS AT UNSTABLE SPEED AND IRREGULAR PATH</p>	 <p>TURN KNOB TO RIGHT</p>

UNIVERSO SNIPER
AIRSOFT



DISASSEMBLY

It is not recommended to disassemble the gun unless for general maintenance, or to clear BBs jammed inside the barrel.

1. Remove the magazine by depressing the magazine release.
2. Remove the stock from the receiver (see pg13).
3. Pull the bolt handle to lock the bolt.
4. Check and clear the chamber from any BBs.
5. Using your finger tip, or small pen like tool, press down on the retaining pin 1, from within retaining pin 2, and pull it out from opposite end.
6. Pull retaining pin 2 out from the receiver. The pin is seated tightly in the receiver, considerable effort may be needed to pull it out.
7. Pull the upper frame upward and forward until it stops on bolt handle.

(continue on next page)

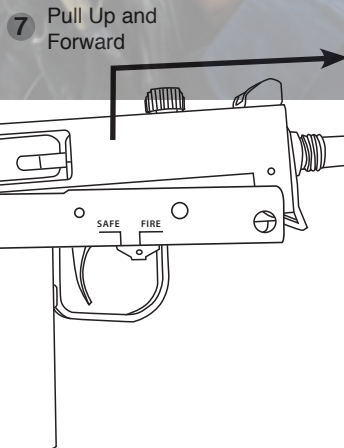
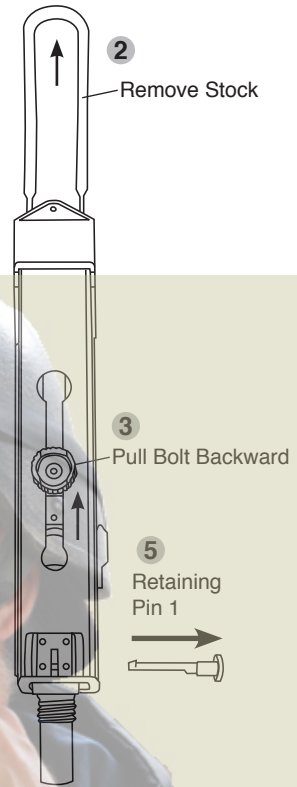

- Turn the bolt knob 90° “clockwise” and pull the knob upward and out. The bolt handle “cut-out” should be aligned parallel to the slide in order to remove the bolt handle.
- Remove the upper frame off of the lower frame.
- After the upper frame is removed, push the bolt backward and then lift the bolt upward. Make sure the hook underneath the bolt clears the impact block.

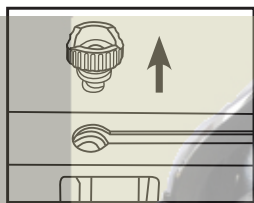

Remove
Knob

8

9 Remove Upper Frame

UNIVERSO SNIPER
AIRSOFT

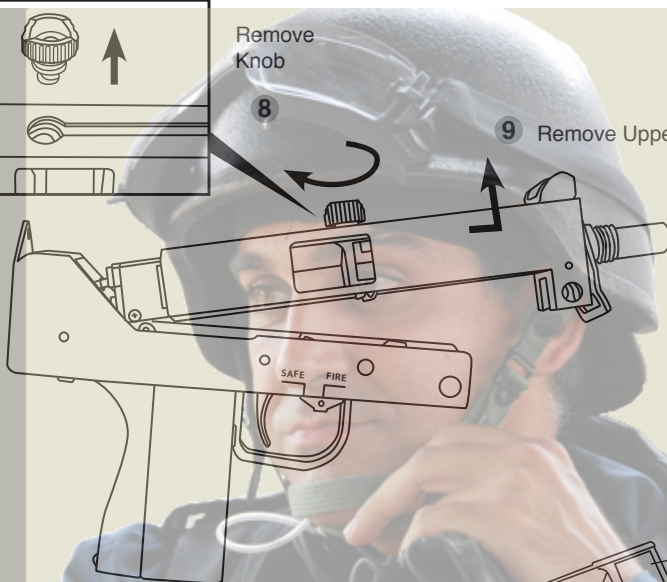

Bolt Assembly

10 Remove Bolt Assembly

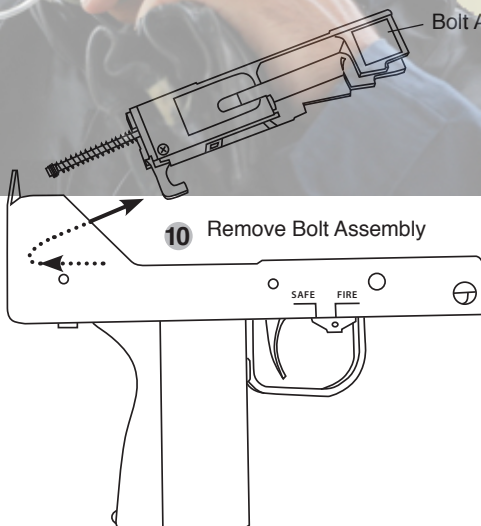

ASSEMBLY

1. Place the recoil spring onto the bolt assembly.
2. Lock the bolt assembly onto the upper frame.
3. Install the upper frame onto the lower frame and align the bolt knob hole. Make sure the hook underneath the bolt hooks onto the impact block
4. Push the bolt knob into the bolt assembly and push the slide assembly to the rear.
5. Align the retaining pin holes.
6. Insert the 2pc retaining pins.
7. Cycle the bolt to assure proper reassembly before shooting.

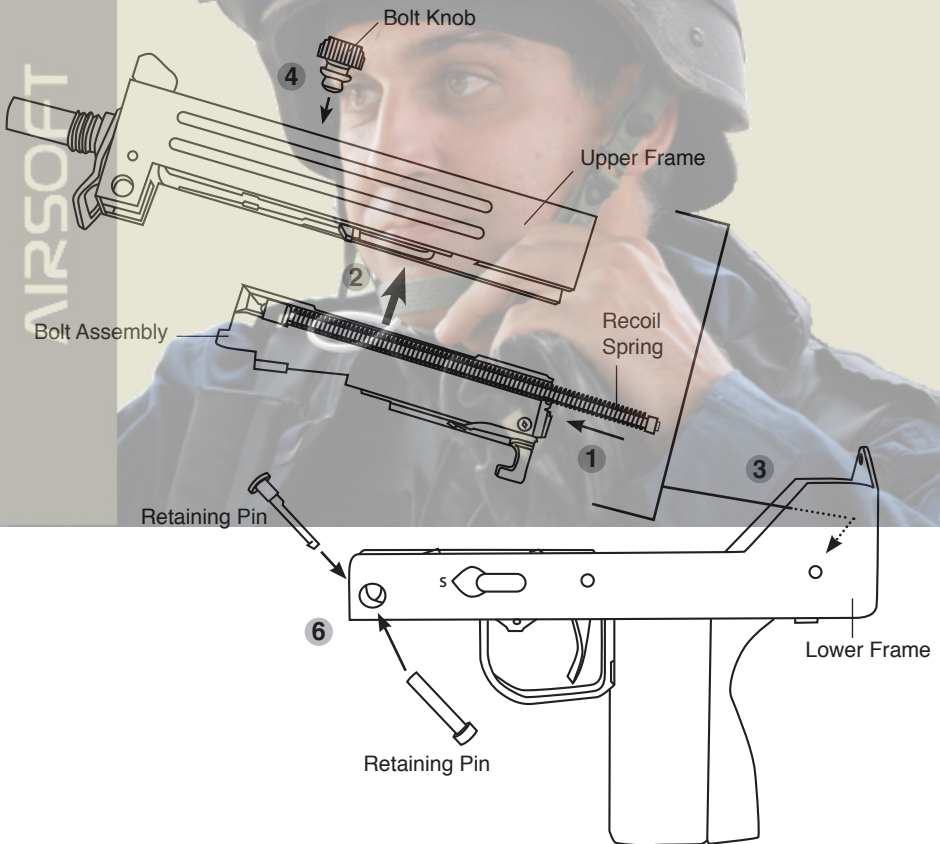

BASIC TROUBLESHOOTING GUIDE FOR SMG

SYMPTOMS	POSSIBLE CAUSE	SOLUTIONS
Bolt jams / Will not complete cycle	Dry internal	Add silicone to cylinder / main seal/ rails
Double feeds BBs into chamber / BBs roll out of barrel	Hop-up adjustment too tight	Release hop-up or replace bucking
BBs will not release from magazine / bent mag lip/ check BB condition	Bended magazine lip	Replace magazine lip
Leaking release valve & charging valve	Dry O-ring	Add silicone oil to valves
Magazine base plate will not lock	Broken base plate lock	Replace base plate lock
Magazine base leaking air	Worn out base seal	Replace magazine base seal
Cylinder will not load BBs into chamber	Broken Cylinder tap	Replace cylinder



GENERAL MAINTENANCE FOR KWA GAS BLOW BACK

Green gas is a liquid propellant which tends to dry out the seals and o-rings. With lubricating silicone oil, it will extend the life of the seals and o-rings and prevent gas leaks.

Use only the recommended 100% silicone oil, available for purchase at the Airsoft dealer where you purchased your KWA products. Any other type of lubricant may damage the products.

Lightly lubricate the recoil spring, cylinder and moving parts with a few drops of oil. Lubricating the seals and o-rings are essential. Unload BBs from the magazine. Make sure the magazine is free of gas before lubricating the magazine's charging valve and release valve.

UNIVERSO SNIPER
AIRSOFT



OPERATING UNDER UNUSUAL CONDITIONS

Unusual conditions are defined as any condition requiring special maintenance. Perform maintenance outlined for the climate similar to your operational area

Extreme Cold:

Operating an Airsoft gas gun in extremely cold temperatures is not recommended. Cold temperatures will cause the Hop-up Bucking to harden, reducing its effectiveness. Gas will not expand properly in cold temperatures, so both the cycling rate and power will be dramatically reduced.

Extreme Heat:

Operating an Airsoft gas gun in extremely hot temperatures is also not recommended. Leaving the gun in direct sunlight for long periods of time, or operating in extremely hot areas will cause the gas to over-expand, damaging the internal workings of the gun. The increase in internal pressure from the expanding gas can also damage the seals and cause leaks in the magazine.

Dust or Sand:

Dust or sand can get into a gas gun and cause malfunctions and/or excessive wear. Keep the gun covered whenever possible. Use lubricant sparingly, as lube naturally attracts dirt and other particles. After use in a dusty area, always field strip the gun (refer to Disassembly Section) and clean any areas you can reach with a soft, lint-free cloth.

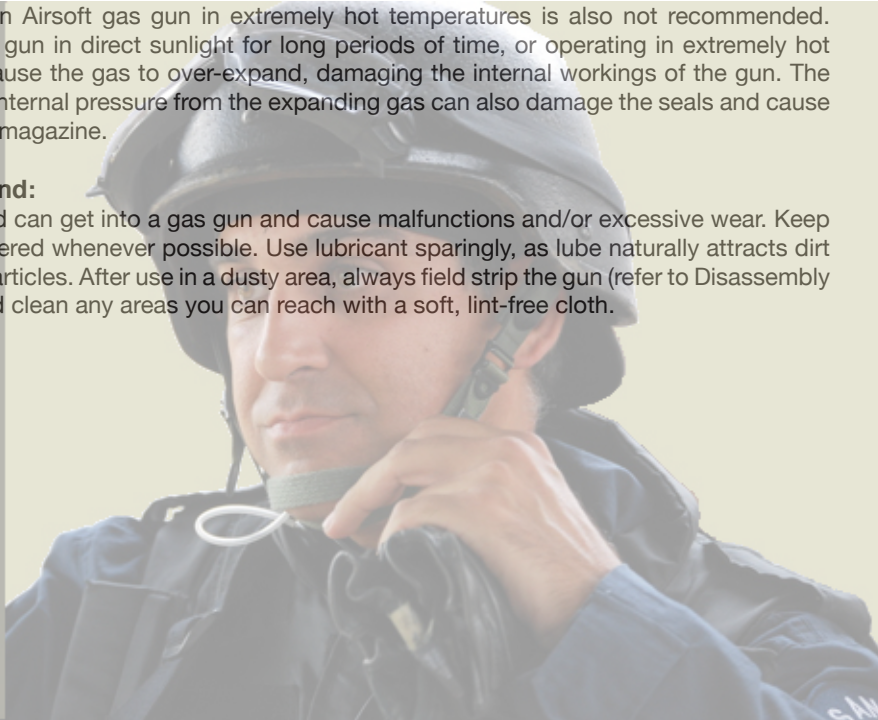

UNIVERSO GAIPER
AIRSOFT

DIAGRAM

UNIVERSO SNIPER
AIRSOFT

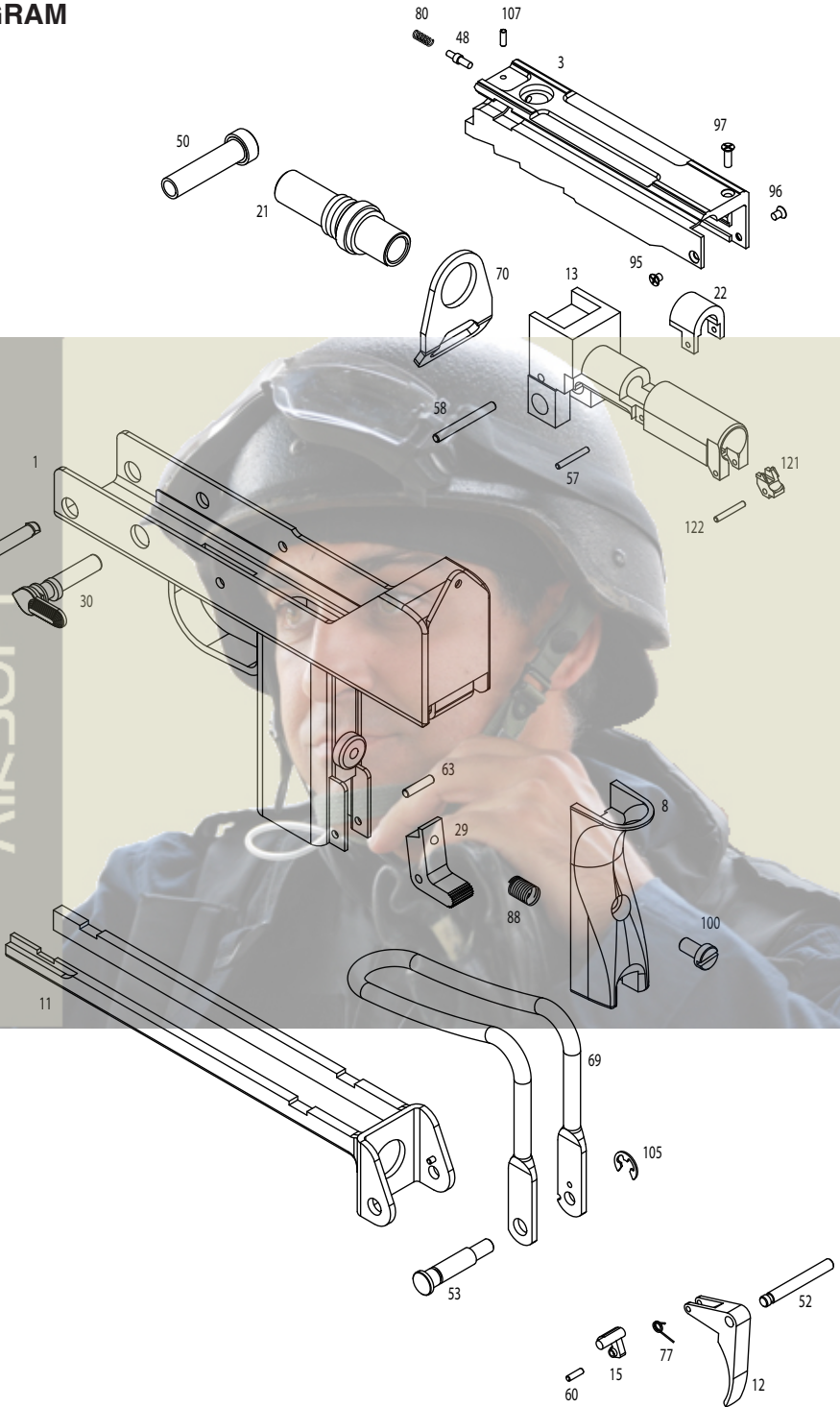

UNIVERSO SNIPER
AIRSOFT

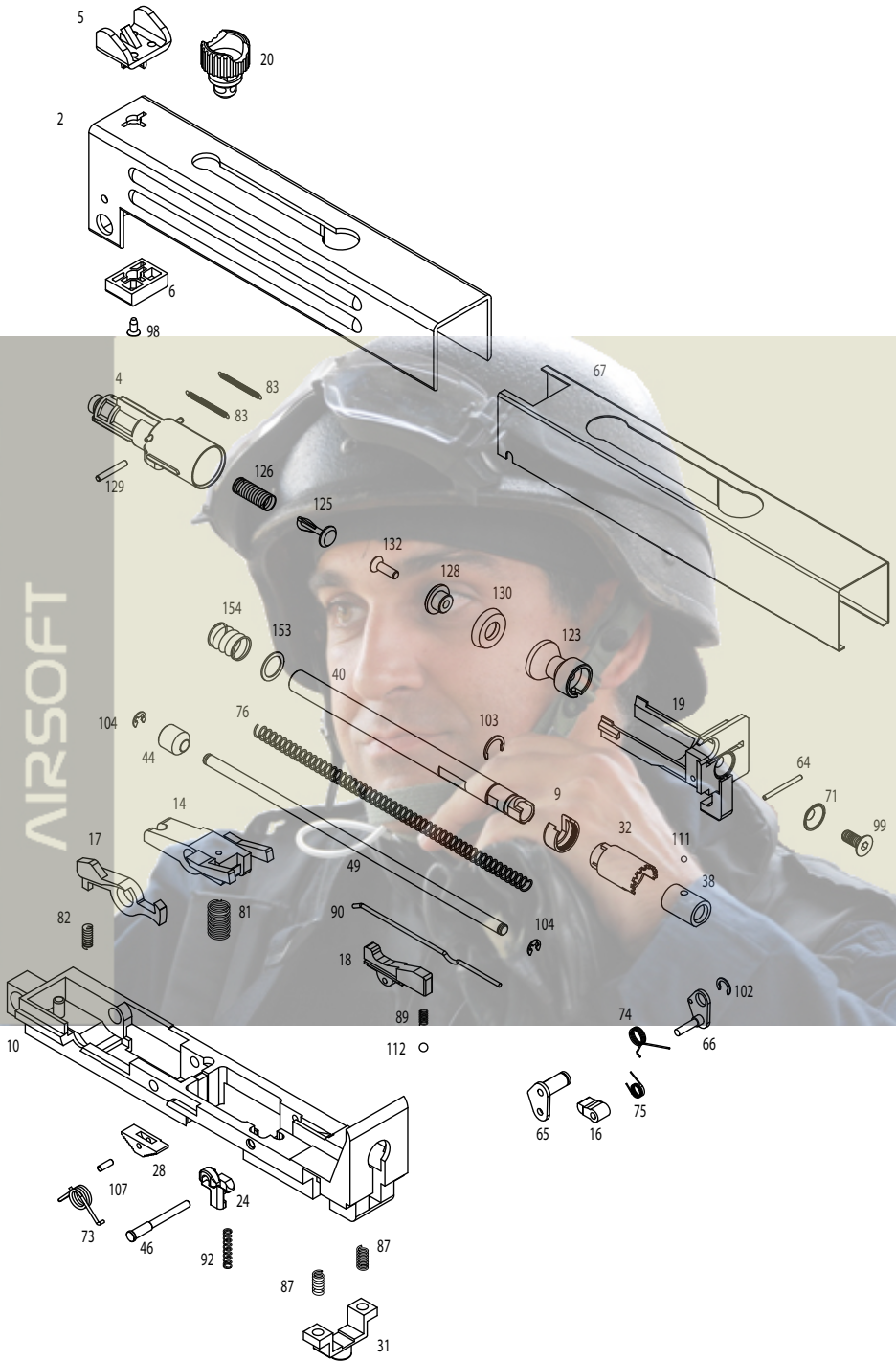

PARTS LIST

Parts #	Description
199-0105-1	LOWER FRAME
199-0105-2	UPPER FRAME
199-0105-3	BOLT
199-0105-4	CYLINDER
199-0105-5	FRONT SIGHT
199-0105-6	FRONT SIGHT BASE
199-0105-8	GRIP
199-0105-9	HOP-UP CYLINDER RETAINING
199-0105-10	INNER FRAME
199-0105-11	WIRE STOCK
199-0105-12	TRIGGER
199-0105-13	INNER BARREL BASE
199-0105-14	BOLT STOP
199-0105-15	SEAR
199-0105-16	IMPACT BLOCK
199-0105-17	SEAR DISCONNECTOR
199-0105-18	SAFETY BASE
199-0105-19	BREACH BASE
199-0105-20	BOLT HANDLE
199-0105-21	OUTER BARREL
199-0105-22	INNER BARREL CLIP
199-0105-24	IMPACT BLOCK RESET BUTTON
199-0105-28	SAFETY
199-0105-29	MAGAZINE RELEASE LEVER
199-0105-30	SELECTOR LEVER
199-0105-31	STOCK RELEASE BUTTON
199-0105-32	HOP-UP CYLINDER
199-0105-38	HOP-UP BUCKING
199-0105-40	INNER BARREL
199-0105-44	RECOIL SPRING GUIDE FOLLOWER
199-0105-46	IMPACT BLOCK PIN
199-0105-48	BOLT HANDLE PLUNGER
199-0105-49	RECOIL SPRING GUIDE
199-0105-50	TAKE DOWN PIN
199-0105-51	TAKE DOWN PIN LOCK

Parts #	Description
199-0105-52	TRIGGER PIN
199-0105-53	STOCK PIN
199-0105-57	INNER BARREL CLIP PIN
199-0105-58	OUTER BARREL RETAIN- ING PIN
199-0105-60	SEAR PIN
199-0105-63	MAGAZINE RELEASE LEVER PIN
199-0105-64	CYLINDER RETURN SPRING
199-0105-65	IMPACT BLOCK HOUSING " LEFT"
199-0105-66	IMPACT BLOCK HOUSING " RIGHT"
199-0105-67	INNER SLIDE HOUSING
199-0105-69	FOLDING STOCK
199-0105-70	SWIVEL
199-0105-71	MAIN SEAL BASE SCREW WASHER
199-0105-73	TRIGGER SPRING
199-0105-74	IMPACT BLOCK HOUSING SPRING
199-0105-75	IMPACT BLOCK SPRING
199-0105-76	RECOIL SPRING
199-0105-77	SEAR SPRING
199-0105-80	BOLT HANDLE PLUNGER SPRING
199-0105-81	BOLT STOP SPRING
199-0105-82	SEAR DISCONNECTOR SPRING
199-0105-83	CYLINDER RETURN SPRINGS
199-0105-87	STOCK RELEASE BUTTON
199-0105-88	MAGAZINE RELEASE LEVER SPRING
199-0105-89	SAFETY SPRING
199-0105-90	TRIGGER PIN RETAINING SPRING
199-0105-92	IMPACT BLOCK RESET BUTTON
199-0105-95	BREACH BASE SCREW "SMALL"
199-0105-96	BREACH BASE SCREW "SMALL"
199-0105-97	BREACH BASE SCREW "LARGE"

Parts #	Description
199-0105-98	FRONT SIGHT BASE SCREW
199-0105-99	MAIN SEAL BASE SCREW
199-0105-100	GRIP SCREW
199-0105-102	IMPACT BLOCK HOUSING RETAINER
199-0105-103	HOP-UP CYLINDER RETAINING RING E-CLIP
199-0105-104	RECOIL SPRING GUIDE E-CLIPS X2
199-0105-105	FOLDING STOCK PIN E-CLIP
199-0105-107	SAFETY PIN
199-0105-111	HOP-UP BALL BEARING
199-0105-112	SAFETY SWITCH BALL BEARING
199-0105-121	BB FEED RAMP
199-0105-122	BB FEED RAMP PIN
199-0105-123	MAIN SEAL BASE
199-0105-125	JET NOZZLE / PLUNGER
199-0105-126	JET NOZZLE SPRING
199-0105-128	MAIN SEAL CAP
199-0105-129	JET NOZZLE PIN
199-0105-130	MAIN SEAL
199-0105-132	MAIN SEAL CAP SCREW
199-0105-153	INNER BARREL SPRING WASHER
199-0105-154	INNER BARREL SPRING

MAGAZINE DIAGRAM AND PARTS LIST

UNIVERSO SNIPER
AIRSOFT

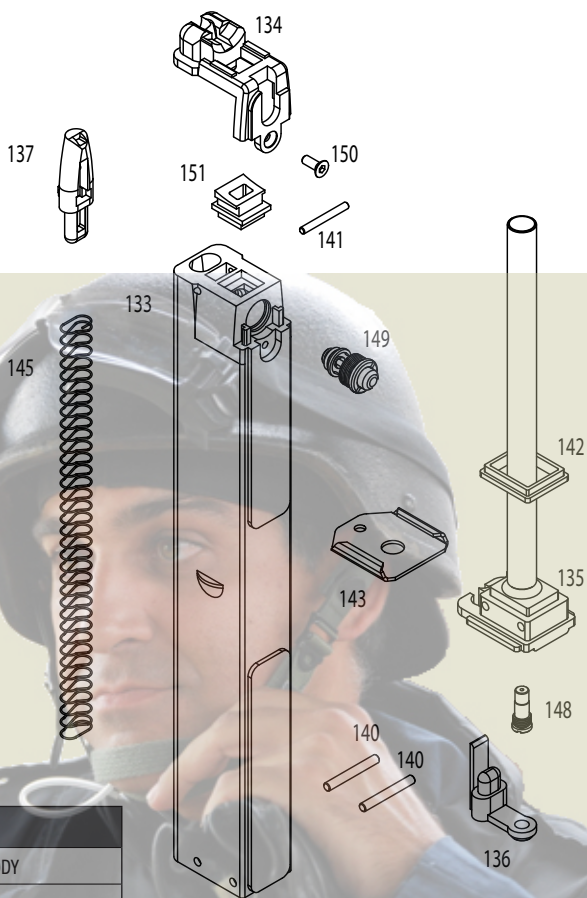

Parts #	Description
199-0105-133	HI CAP MAGAZINE BODY
199-0105-134	MAGAZINE LIP
199-0105-135	HI CAP MAGAZINE BASE & GAS
199-0105-136	MAGAZINE BASE PLATE LOCK
199-0105-137	MAGAZINE FOLLOWER
199-0105-140	MAGAZINE BASE PINS X2
199-0105-141	MAGAZINE LIP PIN
199-0105-142	MAGAZINE BASE SEAL
199-0105-143	MAGAZINE BASE PLATE
199-0105-145	HI CAP MAGAZINE FOLLOWER SPRING
199-0105-148	MAGAZINE CHARGING VALVE
199-0105-149	MAGAZINE RELEASE VALVE
199-0105-150	MAGAZINE LIP SCREW
199-0105-151	MAGAZINE NOZZLE SEAL

UNIVERSO SNIPER
AIRSOFT



KWA Performance Industries, Inc.
18571 E. Gale Ave
City of Industry, CA 91748
T: 626.581.1777 • F: 626.581.0777
www.kwausa.com