

UNIVERSO SNIPER
AIRSOFT



King Arms

M1 Carbine Series Gas Blowback Rifle Instruction Manual

Please read through all instructions before operating this GBB rifle



⚠ WARNING

- User of this GBB rifle must be 18 years of age or older.
- The shooting range of the plastic BB bullet can reach up to 100 meters, beware at all time. Careless shooting may cause eye or other injuries.
- Read through this Handling and Instruction Manual carefully before operating this GBB rifle.

WARNING

Please read through this Manual carefully before operating this gun.

This sport gun is developed for recreational use and it is capable to shoot BB bullets as a projectile so please be caution when handling or using this gun. Please pay special attention for safe operation and remember the warnings and be cautions at all times. Careless shooting or improper use is dangerous, and it can cause damage or injury on human or animal.

Operating this sport gun must be aged over 18 years old. Users must understand and follow the laws of country before possessing or operating this product.

Always wear eyes protective gear.

NEVER look into the gun muzzle.

NEVER point the gun or to shoot towards a person or an animal.

Store the airsoft gun at places out of reach by children.

Always put the gun in a case or bag when you are carrying it.

Always put your finger away from the trigger except you are ready to fire the gun.

Set selector lever at the "SAFE" position, and remove the magazine when the rifle is not in use.

Even if the magazine is removed, there might be remaining BB bullet in the gun which still can be shooting.

Use only the designated battery charger to charge battery.
Do NOT use battery which is swell-up or damaged.
Do NOT expose battery to water or fire.
Do NOT drop, throw or bend the battery.
Do NOT expose the battery to extreme high or low temperatures.



UNIVERSO SNIPER
AIRSOFT

Introduction



A semi-professional airsoft, build with the latest airsoft technology & full feature. Outstanding performance & exceptional quality! Unstoppable momentum once you had your hand on the grip!

Main material: Nylon Fiber; Steel; CNC 6065 Aluminum Alloy



The Advance is built to outperform the pricing & quality! Enjoy the highest capacity of price values with high performance gearbox setting & full metal constructed.

Main material: Zinc Alloy; Nylon Fiber



An upgraded version of Sport Series! Attractive pricing with perfect balance of weight & durability! It's perfect for immature players.

Main material: Zinc Alloy; Nylon Fiber



Entry-level airsoft with economical price! The Sport Series is granted the title "The King of mobility!" with its light weight & fine performance.

Main material: Nylon Fiber



The airsoft rifle which featured with Gas Blowback system.



12g CO₂ gas operated airsoft rifle.



Green gas is recommend to use for this airsoft rifle.

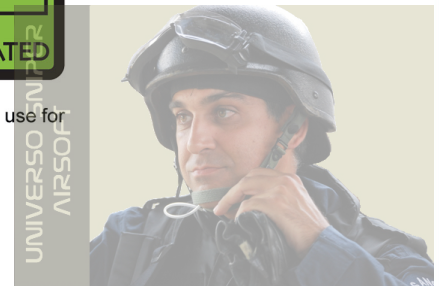

Component Names

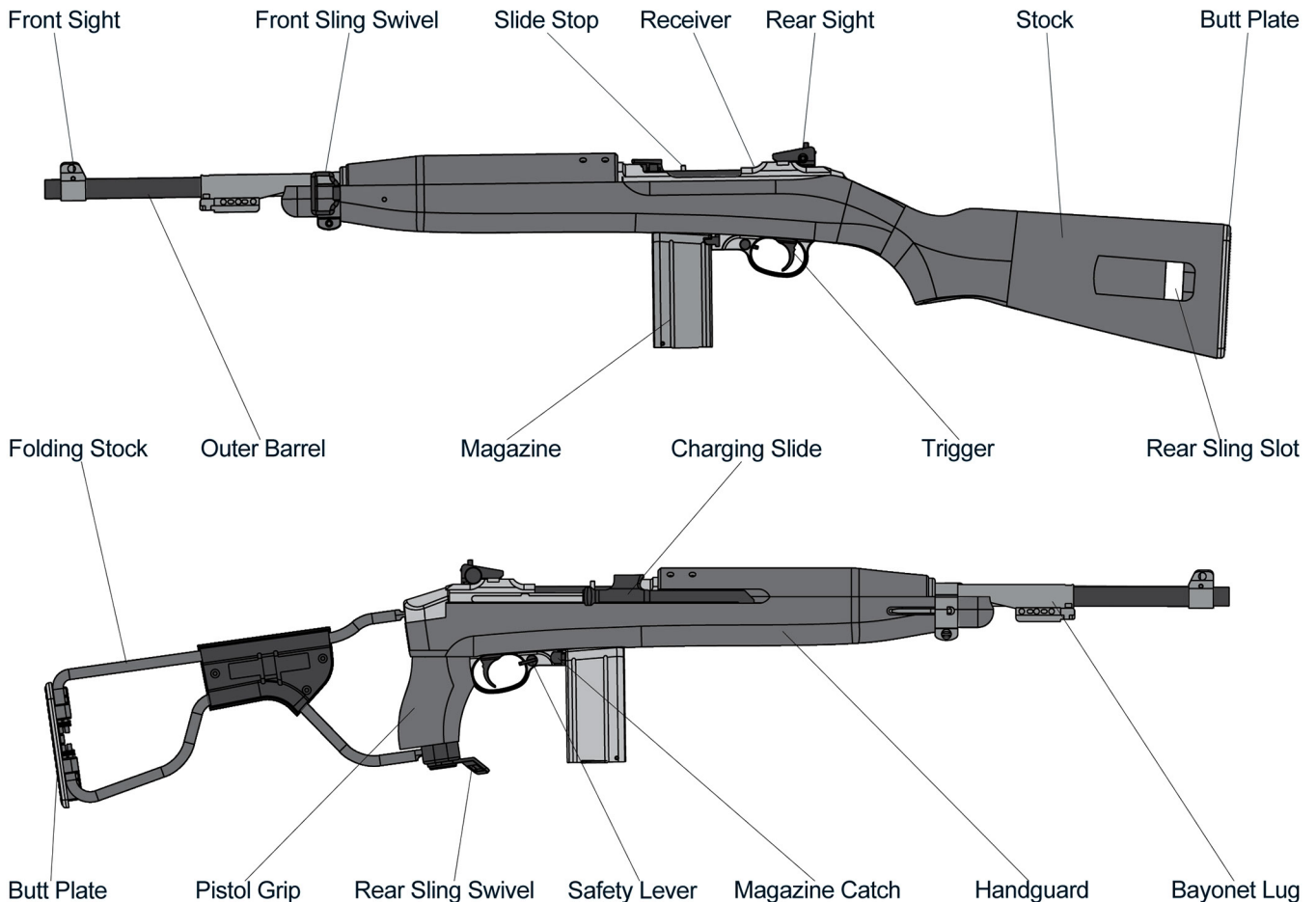

Selector Lever & Safety Setting

WARNING

To prevent malfunction, please do not adjust the selector lever from semi to SAFE position while pulling the trig-

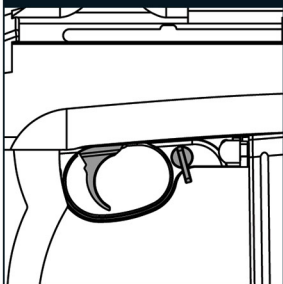

CAUTION: Set the selector lever correctly in position; otherwise, malfunction may occur.

Safety Setting

Always set the lever to the SAFE position and attach the protective cap when you are not firing the gun or during storage. The charging slide and trigger cannot be pulled when the safety is on. Do not attempt to pull it or it will be damaged.

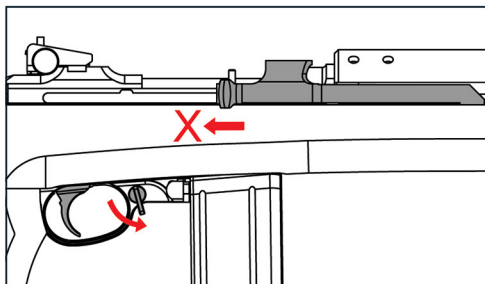

Semi Auto (Single Shot)

To deactivate the safety function, rotate the safety lever in the direction as the arrow shown. The gun will fire one shot each time when the trigger is pulled and the charging slide will be cycled automatically.

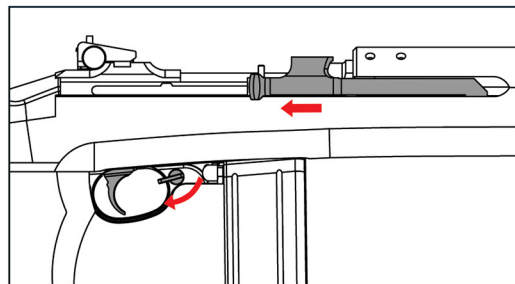

CO2 Cartridge Installation

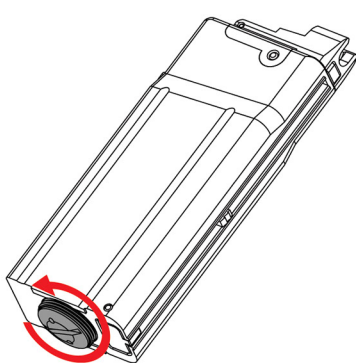

1. Use a tool such as screwdriver, small nose plier or a coin to unscrew the end cap at the magazine bottom in anti-clockwise direction.

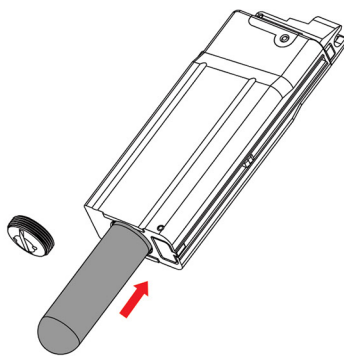

2. Insert the CO2 cartridge into the magazine.

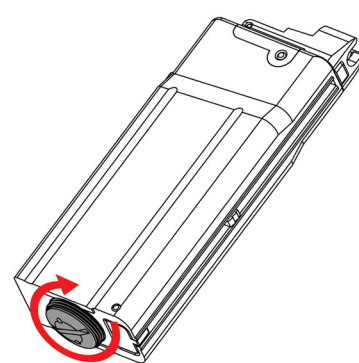

3. Replace the end cap and tighten it in clockwise direction snugly. ***For safety reason, release all the pressure inside the magazine during storage.***

Loading The Magazine

Press down the follower and load the magazine with 6mm BB bullets as the picture shown. Use BB loader to speed up the loading process if needed.

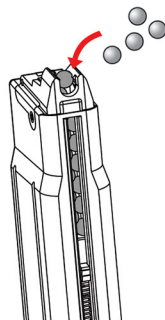

WARNING

Please beware the maximum loading capacity of certain magazine. Do not overfeeding the magazine or it will damage the magazine.

Always use new BB bullets or jamming and damage of rifle may occurs.

6mm

Do not use the following BBs:

X Deficient
 X Broken
 X Oversize
 X Used

Loading The Rifle

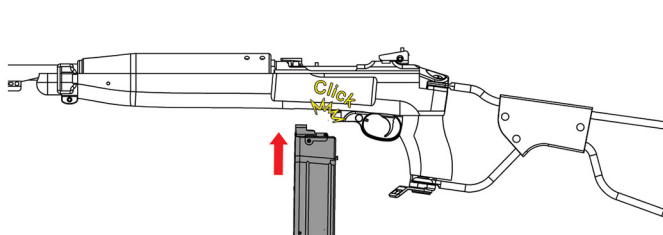

Insert the magazine into the magazine slot until a "Click" sound in heard.

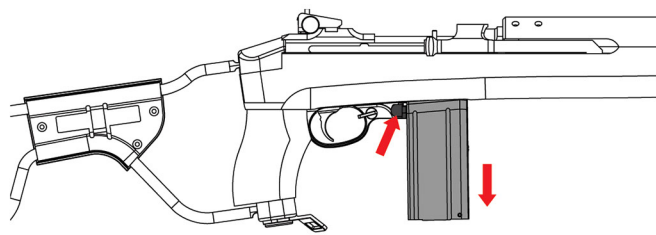

To release the magazine, press the magazine catch next to the safety lever to separate the magazine.



Sight Setting

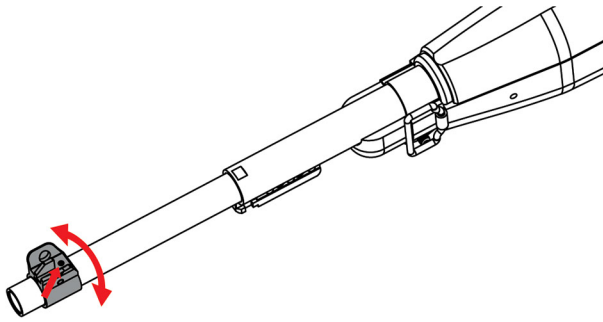

For the adjustment of front sight, loosen the hex screw indicated by arrow first, then rotate the front sight to desired position.

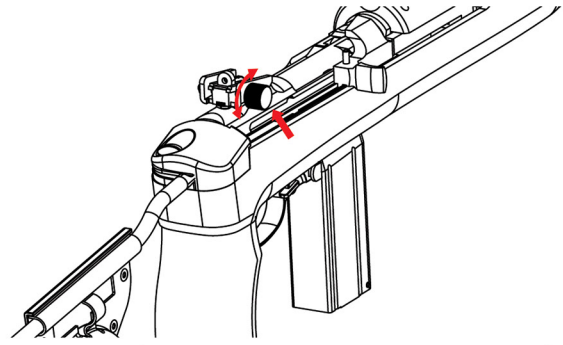

For the adjustment of rear sight, rotate the thumb screw indicated by arrow forwards or backwards to desired position.

Hop-up Adjustment

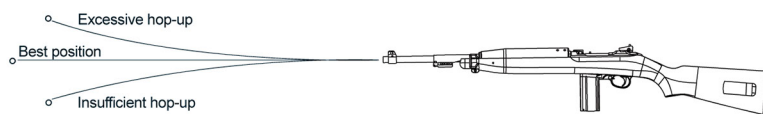

- Turning the hop-up adjustment hex screw excessively can cause bullet clogging. Keep pulling the trigger while bullet being clogged will damage the gun.
- Stop firing the gun immediately if bullet clogging occurs. Rotate the hop-up adjustment hex screw to the "Normal" position and remove the clogging bullets using a clearing rod.
- Make sure to rotate the hop-up adjustment hex screw to the "Normal" position while removing the clogged bullets, otherwise the chamber unit may be damaged.
- Never use dirty or used bullets as dirty chamber will result in unstable hop up.
- Lacking or over spraying of silicone oil will also lead to unstable hop up.

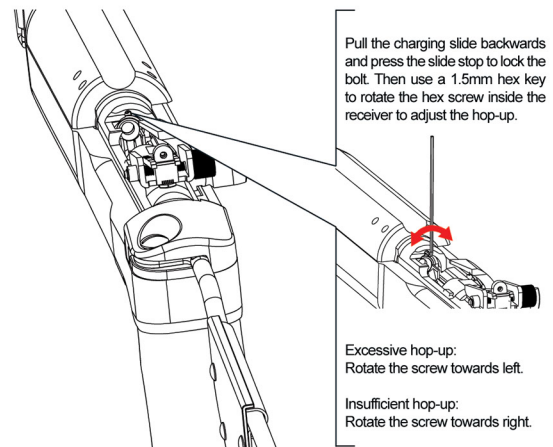

Firing The Rifle

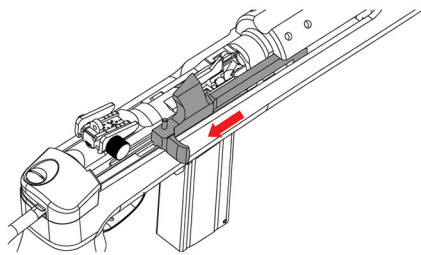

Pull the charging slide backwards to load the rifle. The BBs in the magazine will be loaded into the chamber automatically once the charging slide been released.

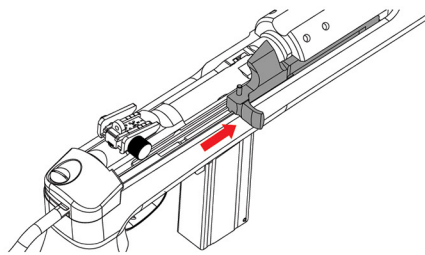

Then release the charging slide, safety off and pull the trigger when ready to fire the rifle. The charging slide will be cycled automatically.

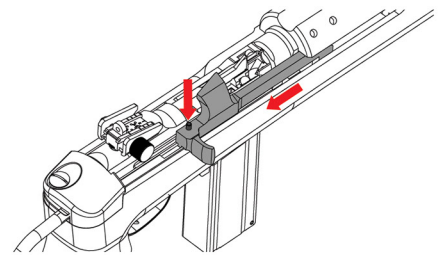

When the rifle is empty, user can pull the charging slide backwards and press the slide stop indicated by arrow to lock the charging slide and change the magazine.

Folding The Stock

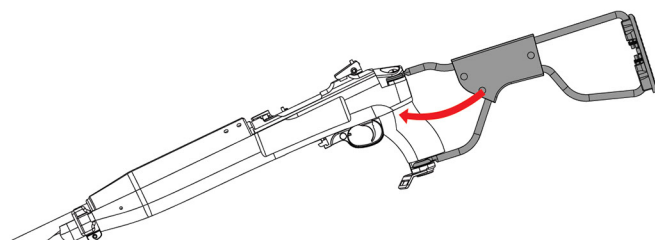

The steel made wire stock can be folded in the direction as the arrow show.

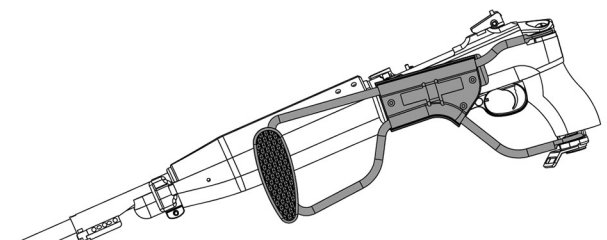

The above picture shows the folded status of the rifle.



Warning

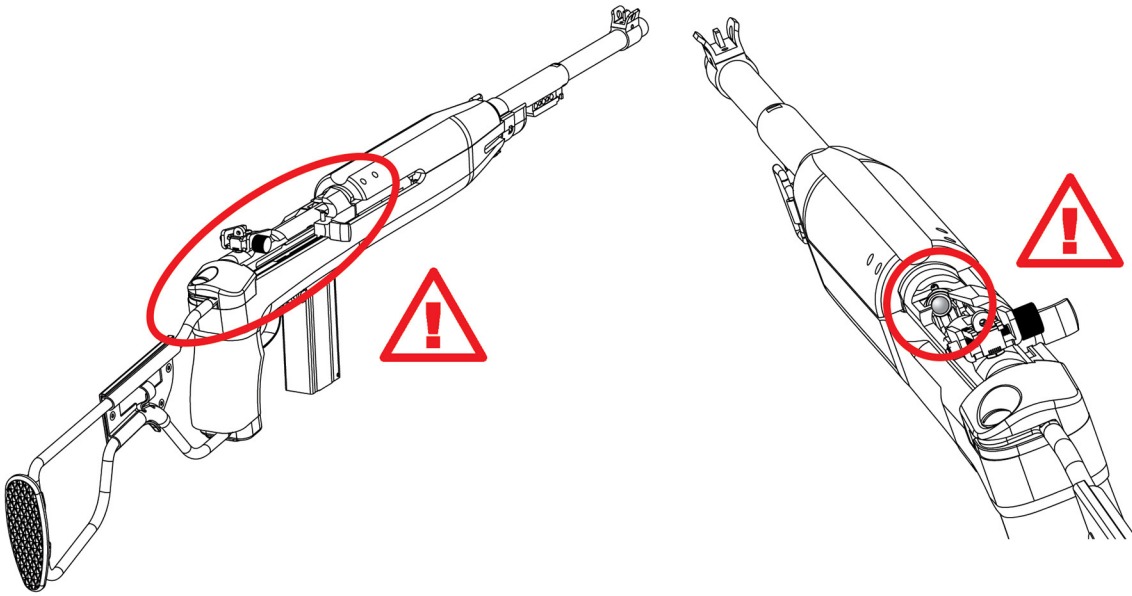

WARNING

- Please beware that there may be still a BBs bullet remained inside the chamber even the magazine is separated. Use a cleaning rod through the muzzle to clear the chamber.
- When the rifle is charged, keep pulling the trigger and the charging slide and bolt will be cycled automatically even the magazine is empty until the all the pressure is released inside the magazine.
- Always keep your body away from the charging slide and bolt while the rifle been cycling and firing such as face or finger, or injury may be resulted.
- Please beware that the magazine would be damaged if fallen on the hard surface.

Cleaning The Inner Barrel & Chamber

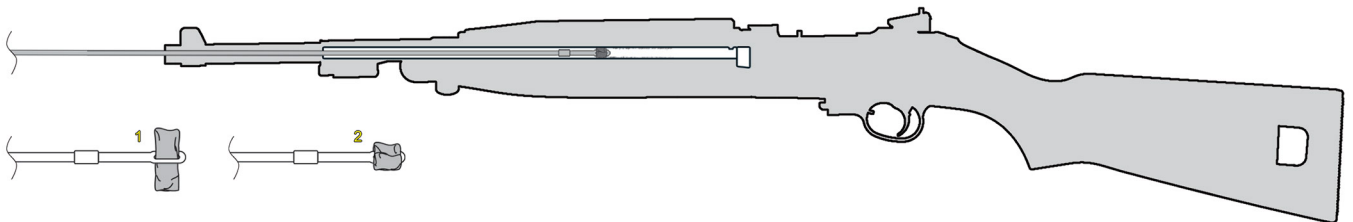

1. A cleaning rod is not included with the package. There is a hole on one end and user can place a piece of cleaning cloth and slide it in the inner barrel to clean the barrel.

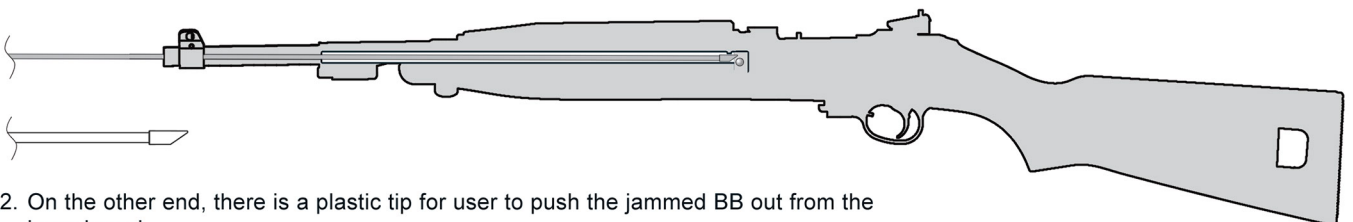

2. On the other end, there is a plastic tip for user to push the jammed BB out from the inner barrel.

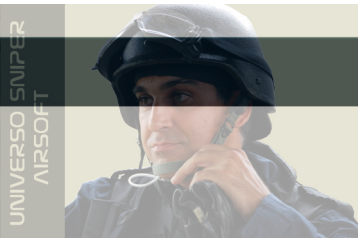

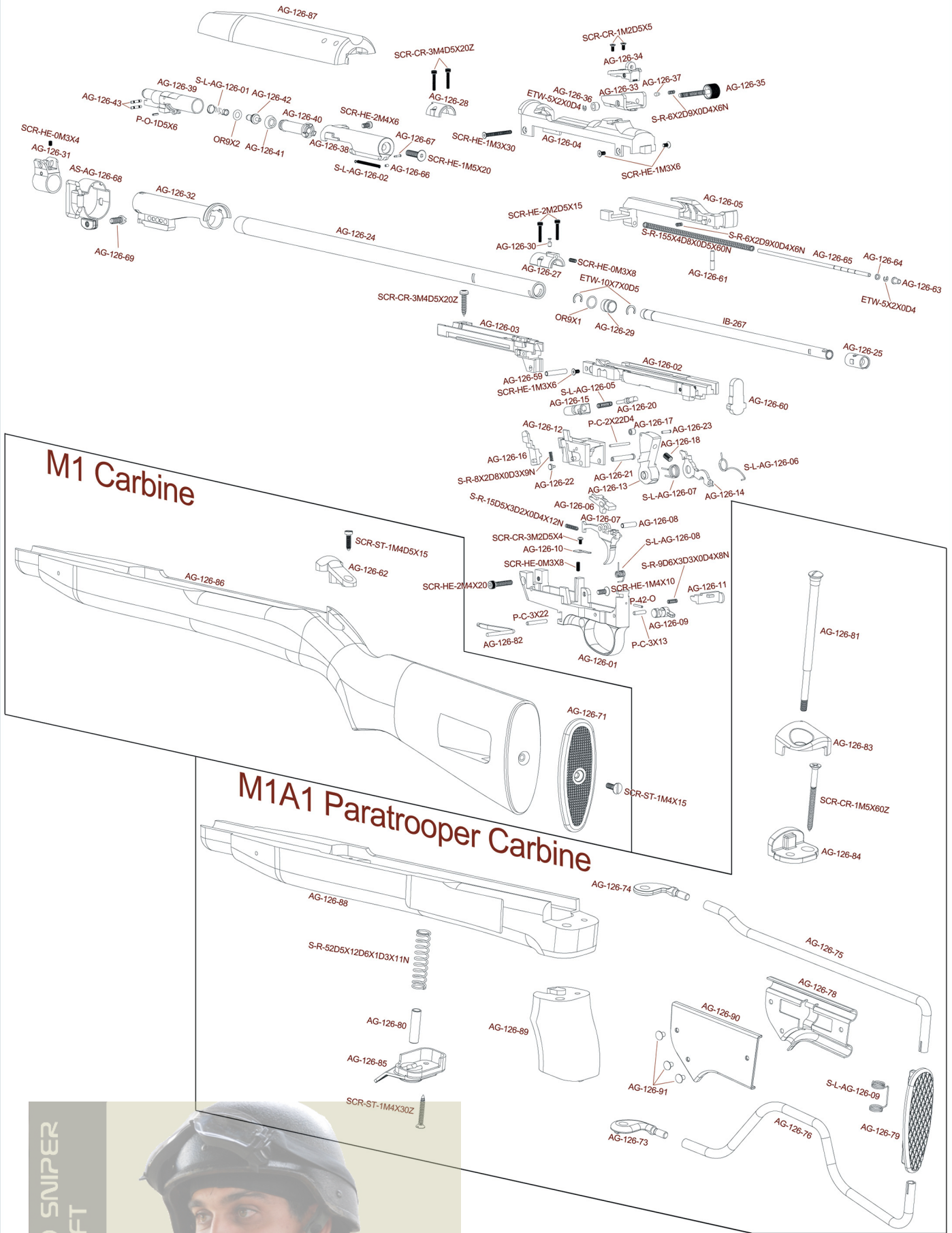

M1 Carbine

M1A1 Paratrooper Carbine

Thank you very much for buying King Arms product.

Airsoft Gun, Parts and Accessories Manufacturer



www.KingArms.com

UNIVERSO SNIPER
AIRSOFT



MUAL-993-A01