



MP5 A2, A3, SD2 & SD3

AUTOMATIC ELECTRIC GUN SERIES

HANDLING CAUTIONS AND INSTRUCTION MANUAL



WARNING

- FOR AGE 18 OR ABOVE.
- PLEASE READ THE INSTRUCTIONS CAREFULLY BEFORE USE. MISUSE OR CARELESS USE MAY CAUSE SERIOUS INJURY.
- USER SHOULD OBEY TO THE LAWS REGARDING THE USAGE AND OWNERSHIP OF AIRSOFT ELECTRIC GUNS.
- FACIAL PROTECTION IS REQUIRED.

**HOP-UP
SYSTEM**

Produced By Classic Army, Hong Kong

1 Outlook / Structure of MP5

Always set the selector switch to the safe position when you are not firing or during storage

MP5 A2 (Tactical Lighted Forearm)

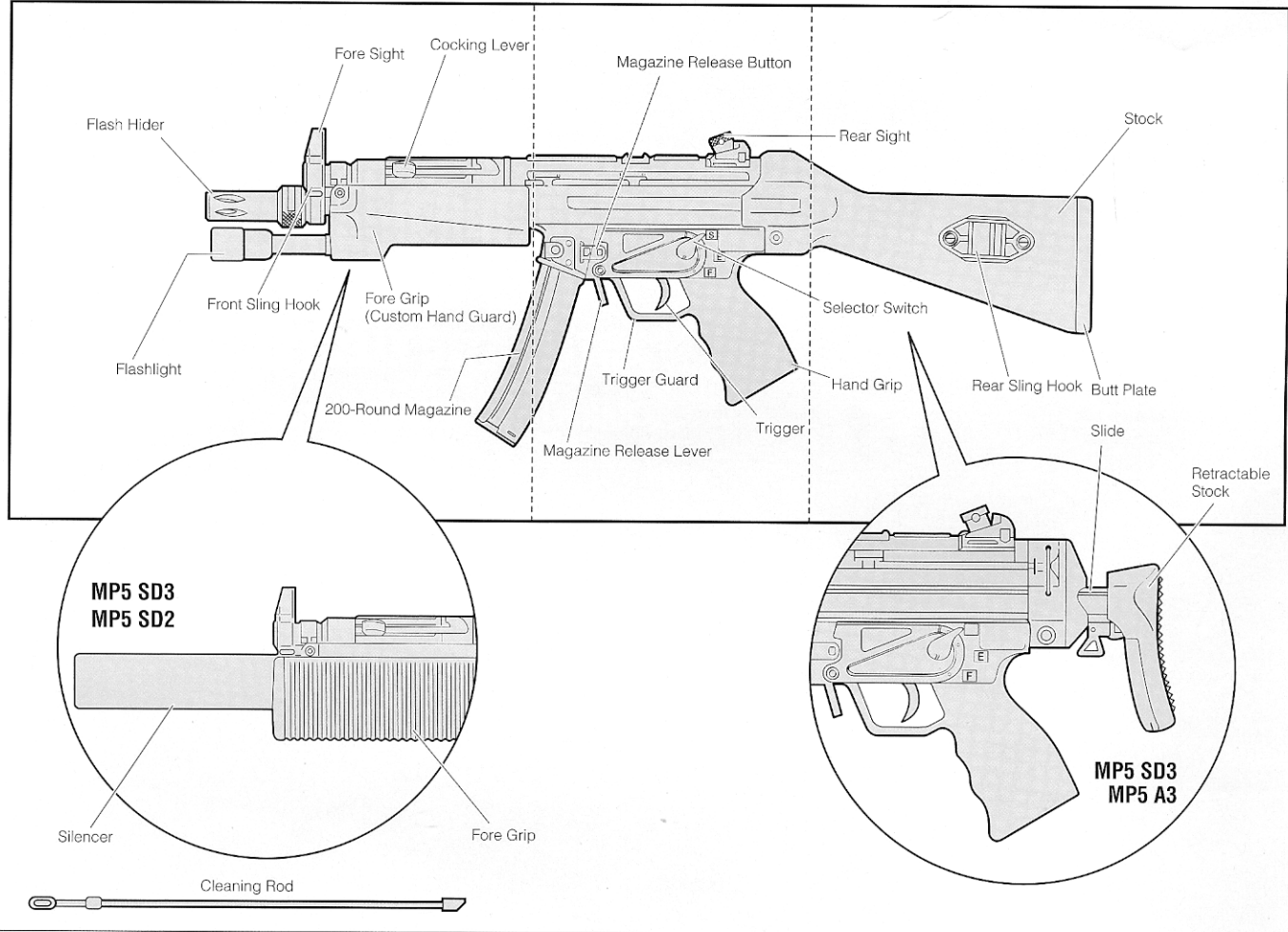

2 Specification

Data of MP5 Electric Air Gun

Name	MP5 A2 (Tactical Lighted Forearm)	MP5 SD2	MP5 A2 (Wide Forearm)
	MP5 A3 (Tactical Lighted Forearm)	MP5 SD3	MP5 A3 (Wide Forearm)
Weight	2.635kg 2.764kg	2.925kg 2.954kg	2.506kg 2.461kg
Barrel Length	229mm	229mm	229mm
Barrel Caliber	6.08mm	6.08mm	6.08mm
Pellet Capacity	200	200	200
Pellet	6mm BB	6mm BB	6mm BB
Initial Bullet Speed	85-95m/sec	85-95m/sec	85-95m/sec
Battery Type	Large Type Mini Type	Large Type Mini Type	Large Type Mini Type

3 How to operate

1 How to use safety lock

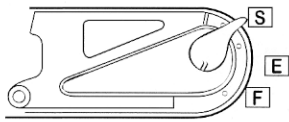

S : Safety Lock

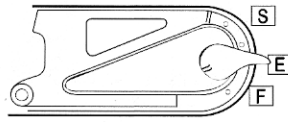

E : Single Lock

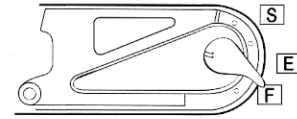

F : Full Auto

2 Magazine Attachment / Detachment procedure

High precision is required for the operation of this magazine. Avoid invasion of dust and dirt into the magazine to prevent malfunctions.

Action against problem

Failure in pellet feeding may occasionally occur during full auto operation. In this case, disconnect the magazine, give a slight shock or poke BB pellets using a stick or poke BB pellets using a stick and then set the magazine again.



About 20 pellets remain in the duct after operation. Be careful of any pellets firing out if you hold the gun up-side-down and pull the trigger.

For smooth pellet feeding.

- Occasionally give slight shocks to the gun or shake vertically for ensuring smooth pellet feeding.
- Turn the gear after every 50 to 60 pellets for ensuring smooth pellet feeding.

- Open the top hatch and insert BB pellets. About 200 pellets can be loaded. (Avoid forcing pellet furiously.)

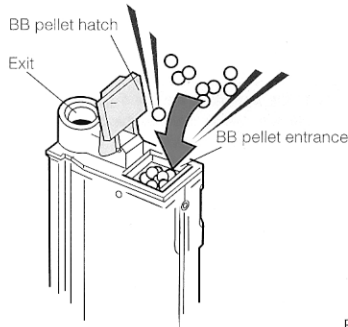

- Close the hatch

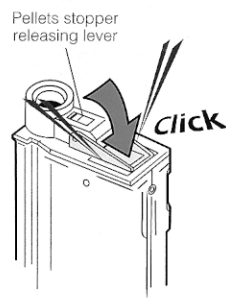

Remove pellets remaining in the duct by reversing the magazine and using the release lever as shown. This ensures smooth operation next time.

- Hold the BB pellet entrance facing upward and turn the gear at the bottom all the way until the click-click sounds change. (If only a small number of BB pellets are inserted, the gear merely makes blank turning.)

Turn the gear all the way until the sound changes.

The gear will not be damaged even if you turn it excessively.

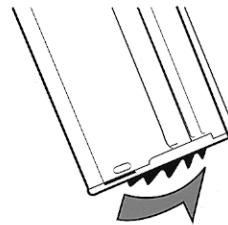

- Check the pellets whether they are lifted up to the exit, and then connect the magazine to the gun.

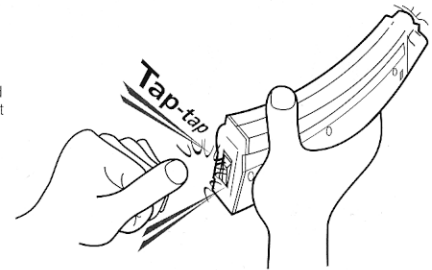

If pellet feeding is frequently faulty, remove all pellets from the magazine and spray silicone oil for 1 to 2 sec. Note that the hop-up operation may become unstable for a while after using silicone oil spray.

3 How to change battery

A2 & SD2

- Remove the butt plate by pressing it downwards and pull out the connector.

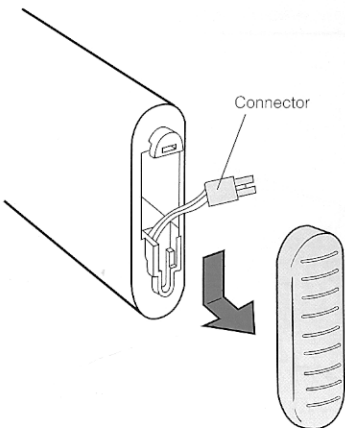

- Insert the battery into the stock and connect the connector.

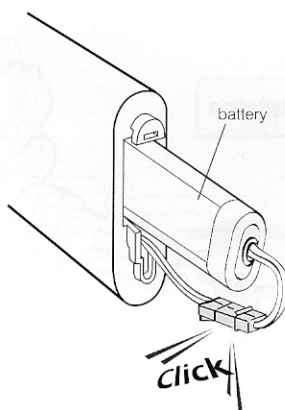

- Insert connector and battery. Bend the cord in S shape.

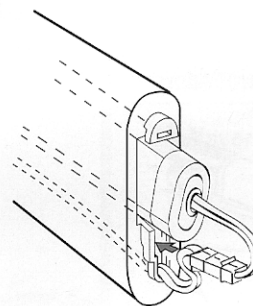

- When the battery and cord are set in position, reinstall the butt plate as shown.

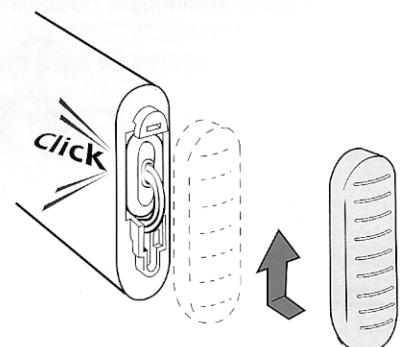

A2 / A3

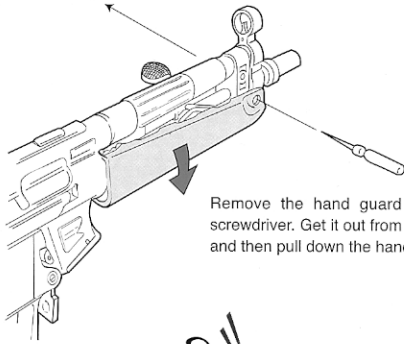

Remove the hand guard pin by using a screwdriver. Get it out from the opposite side and then pull down the hand guard.

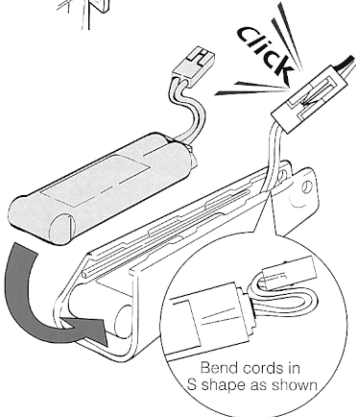

Set the battery in the hand guard, with the cord side facing towards the muzzle, and connect the connector.

Bend cords in S shape as shown

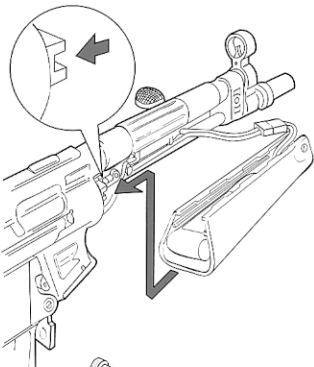

Fit the rib built in the hand guard to the groove shown by the arrow. (Also, set the other side in the same manner.)

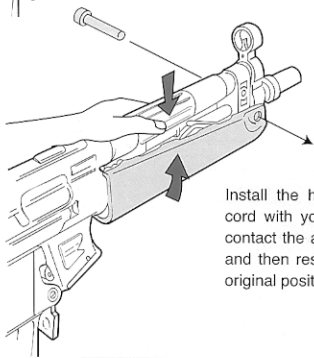

Install the hand guard while securing the cord with your fingers so that they do not contact the area shown by the oblique lines and then restore the hand guard pin to the original position.



• Do not force the fore grip into place. It may bend the handle.

SD2 / SD3

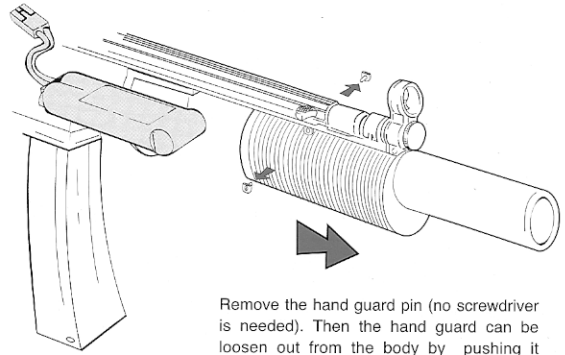

Remove the hand guard pin (no screwdriver is needed). Then the hand guard can be loosened out from the body by pushing it forward.

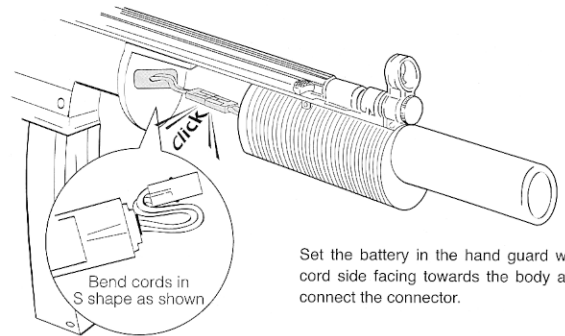

Set the battery in the hand guard with cord side facing towards the body and connect the connector.

Bend cords in S shape as shown

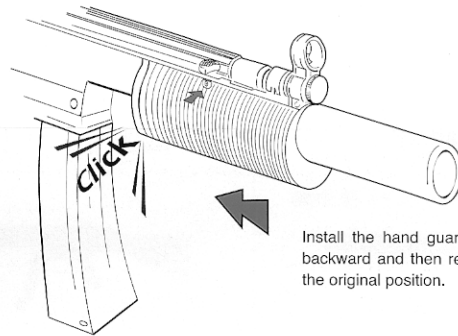

Install the hand guard by pushing it backward and then restore the pin to the original position.

4 Flash Hider Attachment / Detachment procedure

Removal

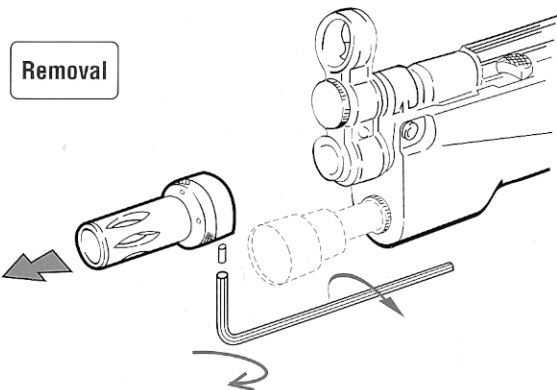

Installation

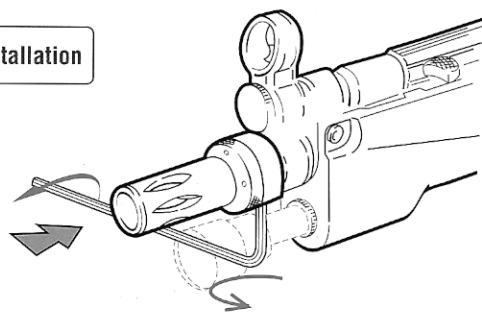

If locking cannot be set, slowly turn to the right or left to adjust the position.

5 How to fire

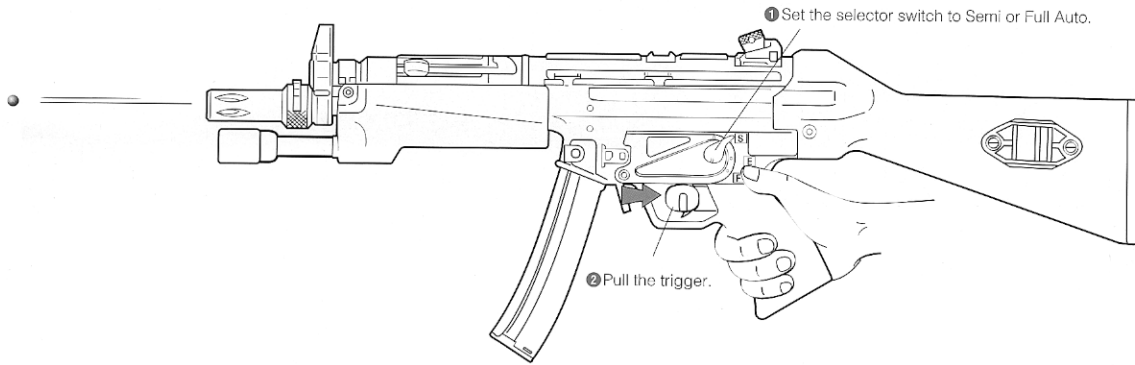

* Blank firing may occur after setting the magazine, this is the normal operation of the gun.

Cautions on Motor and Battery

- Change the battery if the firing cycle becomes slow.
- Give the air gun a rest for 5 to 10 minutes after firing about 500 pellets, in order to ensure high durability of the motor and battery.

When pellets are clogged

- Remove them and apply a few drops of silicone oil into chamber from the magazine entrance as shown or spray silicone oil for 0.5 to 1 sec, to obtain smooth continuous firing. (never use CRC-556 or other mineral oil)



- There are possibilities that no firing occurs after pulling the trigger in the semi auto mode. In this case, do not pull the trigger furiously. Fire 5 to 10 pellets in the full auto mode and then return to the semi auto mode.

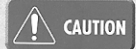

- Smell may be generated from the motor for a while when a new air gun is operated. This is the normal operation of the gun.



- The hop up operation may be unstable for 200 to 300 pellets after using silicone oil. This is the normal operation of the gun.

4 Maintenance

1 How to use a cleaning rod

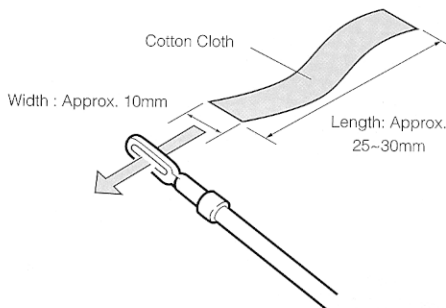

Cut a cotton cloth to the size as shown above and insert one end into the hole in the rod. (Adjust the length of the cloth for smooth entry into the barrel.)

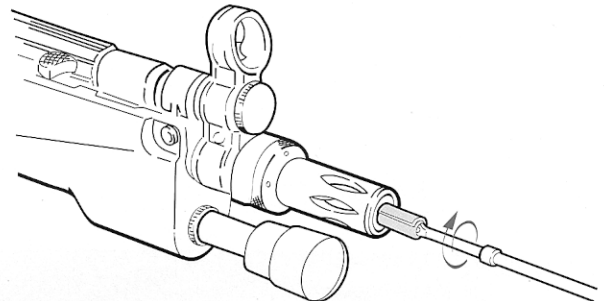

Hold the tip of the rod and insert it with turning motion.



CAUTION: Always begin the maintenance by returning the hop up adjustment lever to NORMAL.



CAUTION: The chamber is a precision component. Never use any used BB pellets.

* The hop-up performance may become unstable for 60 to 70 pellets after maintenance.

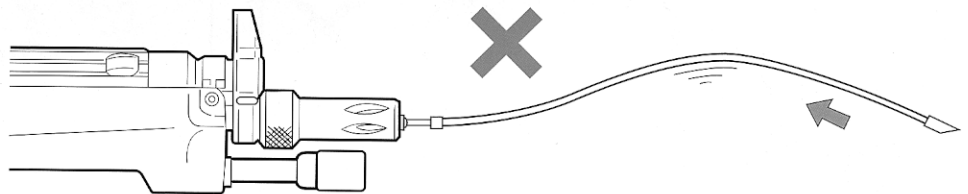

Insert the rod will be difficult if you hold the rod at the end.

1 Spray silicone oil for 0.5 to 1 sec in the pellet entrance, then fire 40 to 50 pellets to make the magazine stable.

2 Clean oil from the chamber using the cleaning rod (with cotton) to complete the maintenance.

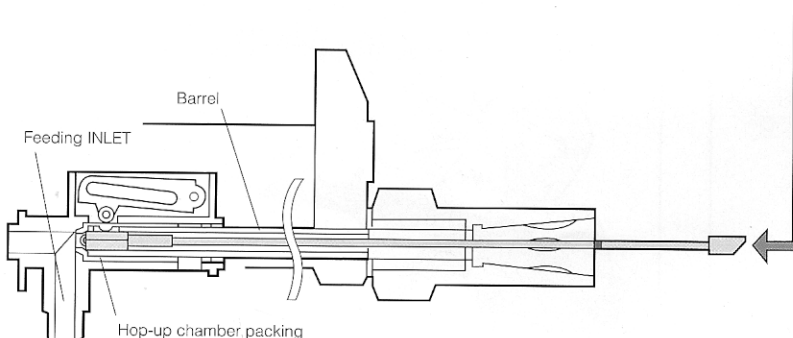

2 Never use any used BB pellets

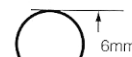

Use new 6mm pellet is a must.

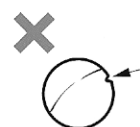

Please don't use any BB pellet which is not completed.

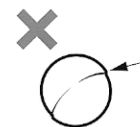

Please don't use any broken BB pellet.

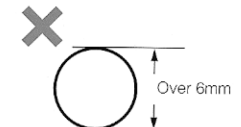

Please don't use any BB pellet which diameter exceeds 6 mm.

5 ! WARNING

Always read this manual before usage.



WARNING

Never point the muzzle at people or animals.

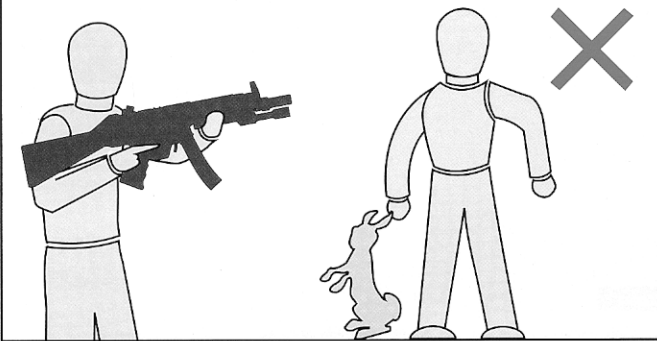

WARNING

Please keep the rifles far away from children.

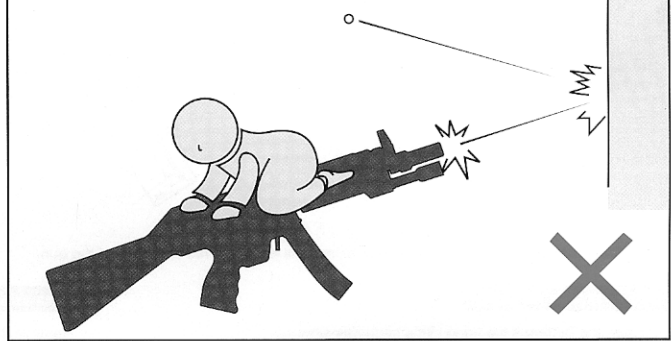

WARNING

Don't try to look at the muzzle directly.

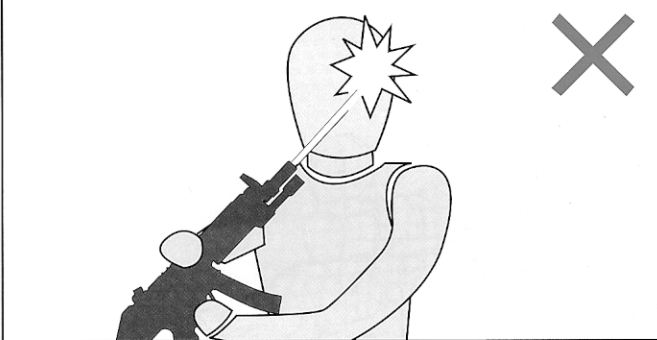

WARNING

Always detach the magazine and battery from the gun during storage.

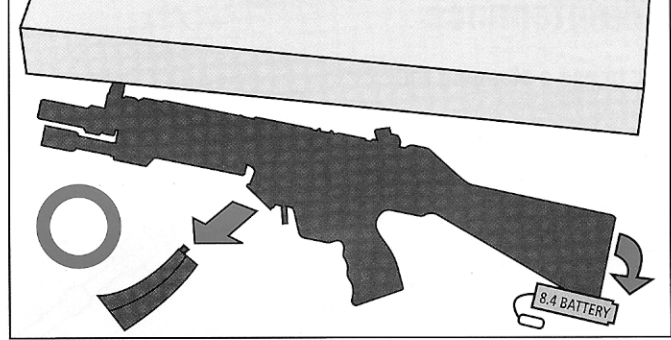

WARNING

Don't hang your finger on the trigger if you are not shooting.

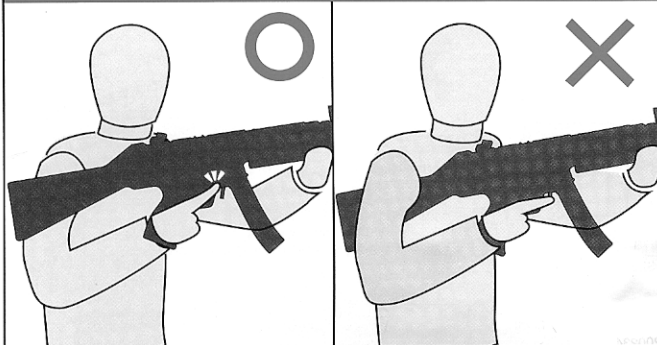

WARNING

Always use new pellets with high quality. Never use pellets that has already been fired.

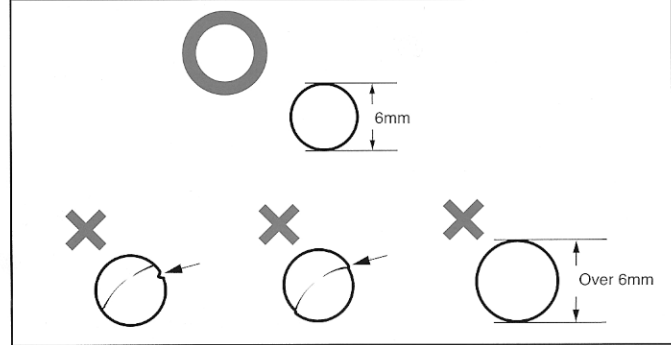

WARNING

Never load the rifle if you don't intend to fire it.

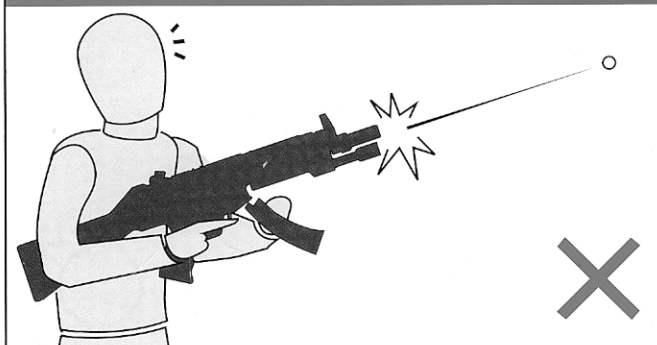

WARNING

Please remember to wear protective glasses or shooting glasses to protect the eyes.

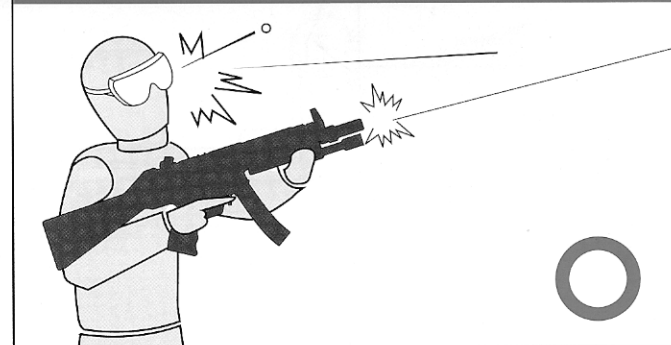

In no event shall Classic Army or any of our partners be liable for any direct or indirect, special, incidental, or consequential damages in connection with the use of our products.

6 Exploded Diagram

