

OPERATING MANUAL

UNIVERSO 21MIL-ER
AIRSOFT

UNIVERSO 21MIL-ER
AIRSOFT

LAAR

Light Automatic Rifle

Cal. 6mm Gas Blowback Rifle

Manufactured by VegaForceCompany, 100% Made in Taiwan



VegaForceCompany
www.vegaforce.com

Caution / Warning

- Always wear eye protective gear.
- Never shoot the gun at places where people and cars can cross.
- Never aim or shoot a person or animal as a target.
- Never look into the gun muzzle.
- Always point the muzzle towards a safe direction.
- Avoid pulling the trigger carelessly.
- Please keep your fingers away from the trigger, except when you are ready to shoot a target.
- Always put the gun in a case or bag when you are carrying it.
- Keep out of reach of children.

注意事項/警告

- 始終佩戴護目鏡。
- 切勿在有人和汽車通過的地方開槍。
- 切勿將人或動物作為目標瞄準或射擊。
- 切勿直視槍口。
- 始終將槍口指向安全的方向。
- 避免不小心拉動扳機。
- 除準備射擊目標外，請不要將手指放在扳機上。
- 攜帶槍支時，請務必將其放在箱子或袋子中。
- 請將本品放在兒童不能接觸的地方。

Specification

- Over all: 1095 mm
- Inner Barrel: 360 mm
- Weight: 3610 g
- Bullet: 6 mm
- Capacity: 20 Rds
- Energy : Max 2 Joule
- Material: Metal , Plastic

產品諸元

- 全長: 1095 mm
- 內管長: 360 mm
- 重量: 3610g
- 彈種: 6 mm
- 填彈數: 20 Rds
- 動能: Max 2 Joule
- 材質: 金屬、塑料



Table of Contents / 目錄

Paragraph Number / Title
段落編號 / 標題

Page Number
頁數

Chapter 1 - Introduction / 章節1-簡介

1-1	Component Name / 組件名稱	02
1-2	Selector and Safety Setting / 選擇鈕與保險	03
1-3	Flip-Up Sights / 折疊式準星照門	04
1-4	Carrying Handle Disassembly / 提把拆卸	05
1-5	Magazine / 彈匣	06

Chapter 2 - Operating Instructions / 章節2-使用說明

2-1	Checking Before You Fire / 射擊前檢查	07
2-2	Load the BBs / 裝填BB彈	09
2-3	Filling the GAS / 填充瓦斯	10
2-4	Setting Magazine / 上彈匣	11
2-5	Ready to Fire / 射擊準備	11
2-6	Release Bolt / 槍機釋放	11
2-7	Variable HOP-UP System / HOP-UP調整系統	12
2-8	Adjust HOP Effect / 調整HOP效果	12

Chapter 3 - Maintenance / 章節3-保養

3-1	Field Stripping / 大部分解	13
3-1	Cleaning and Maintenance / 清潔與保養	18
3-2	Troubleshooting / 故障排除	19

Chapter 1 - Introduction / 章節1-簡介

1-1 Component Name / 組件名稱

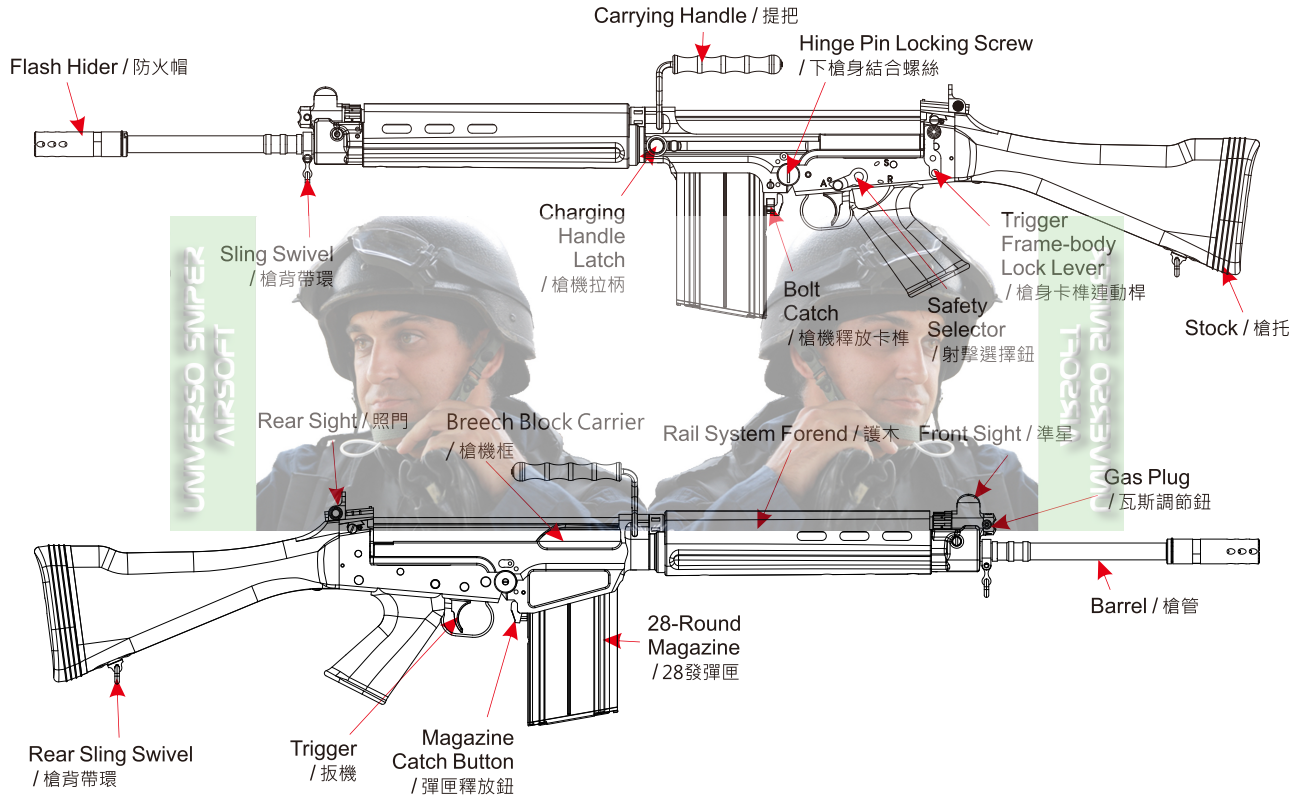

1-2 Selector and Safety Setting / 選擇鈕與保險

The safety is located on the left rear side of the lower receiver. The safety has three positions: SAFE, SEMI and AUTO are all clearly marked on the lower receiver. When the safety is rotated to SAFE position, the rifle (hammer) is fully cocked, but the firing sear is blocked from movement providing protection from accidental discharge under normal usage when the safety is properly engaged and serviceable.

射擊選擇鈕位於下槍身左側。射擊選擇鈕有三種標示：保險/半自動/全自動，皆在下槍身上標出。當射擊選擇鈕旋至保險位置時，擊錘雖已在待發位置，但擊錘阻鐵是不可作動的。在正常情況下提供槍支安全的保護。

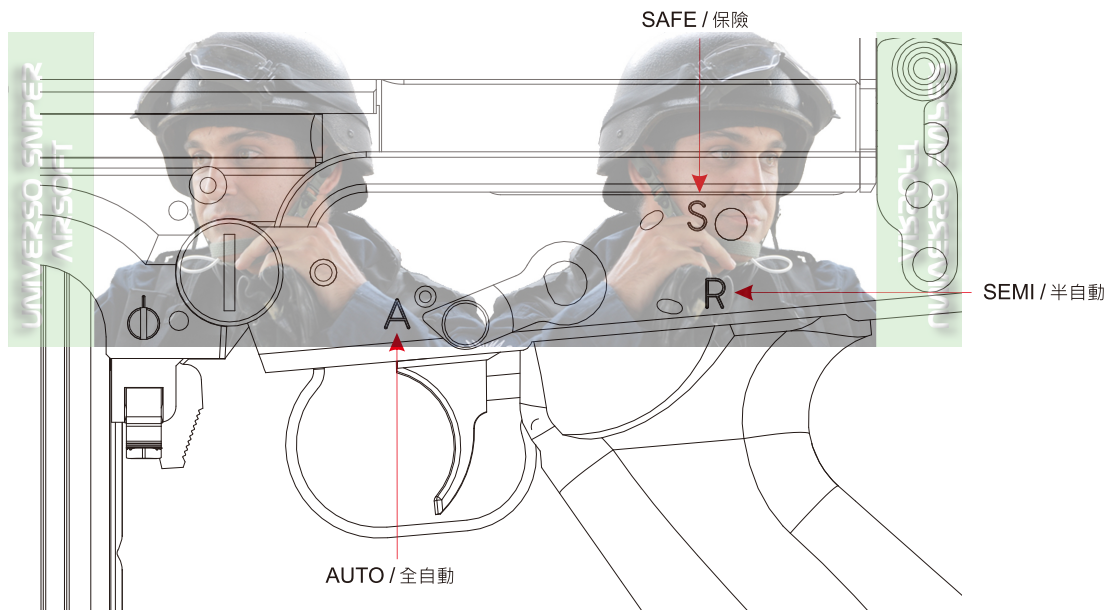

1-3 Sights / 準星照門

A. Front Sight / 準星

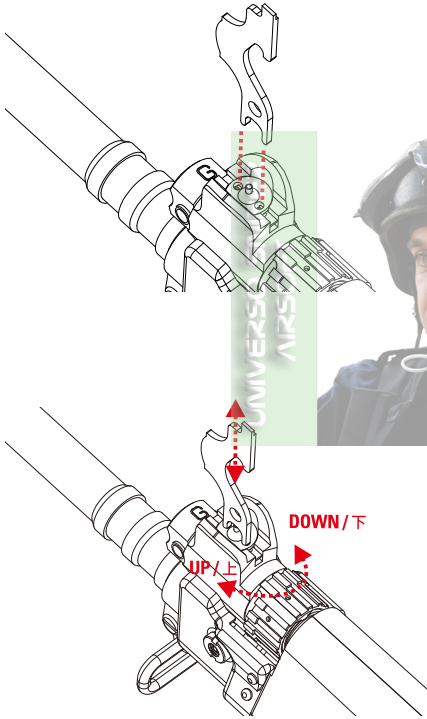

B. Rear Sight / 照門

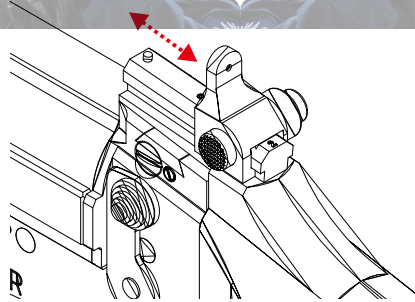
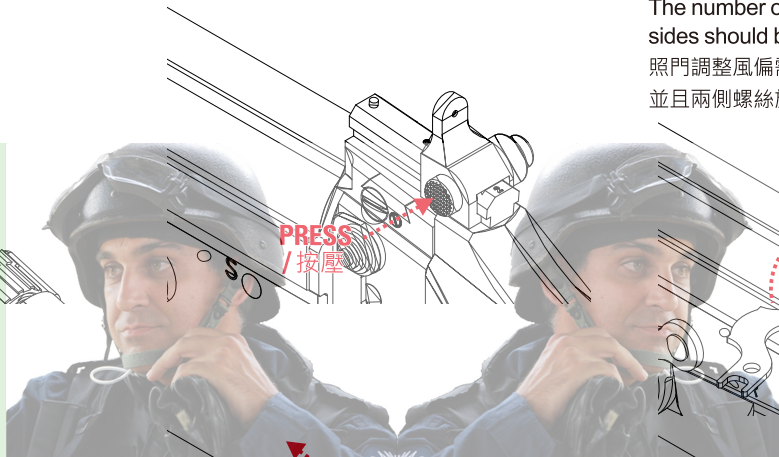

The rear sight adjustment requires adjusting the screws on both sides at the same time. The number of turns of the screws on both sides should be the same.

照門調整風偏需將兩側螺絲一起調整，並且兩側螺絲旋轉圈數需相同。

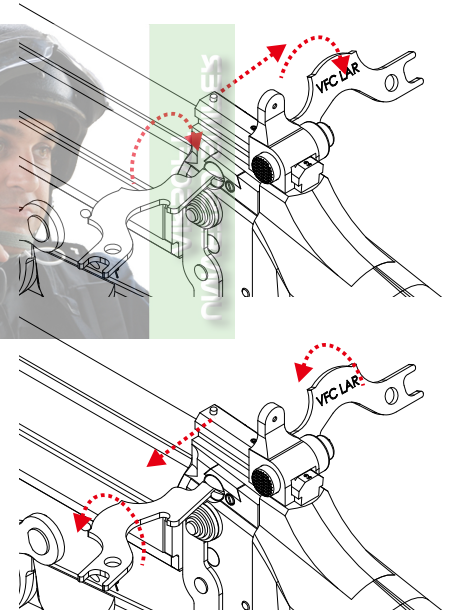

1-4 Carrying Handle Disassembly / 提把拆卸

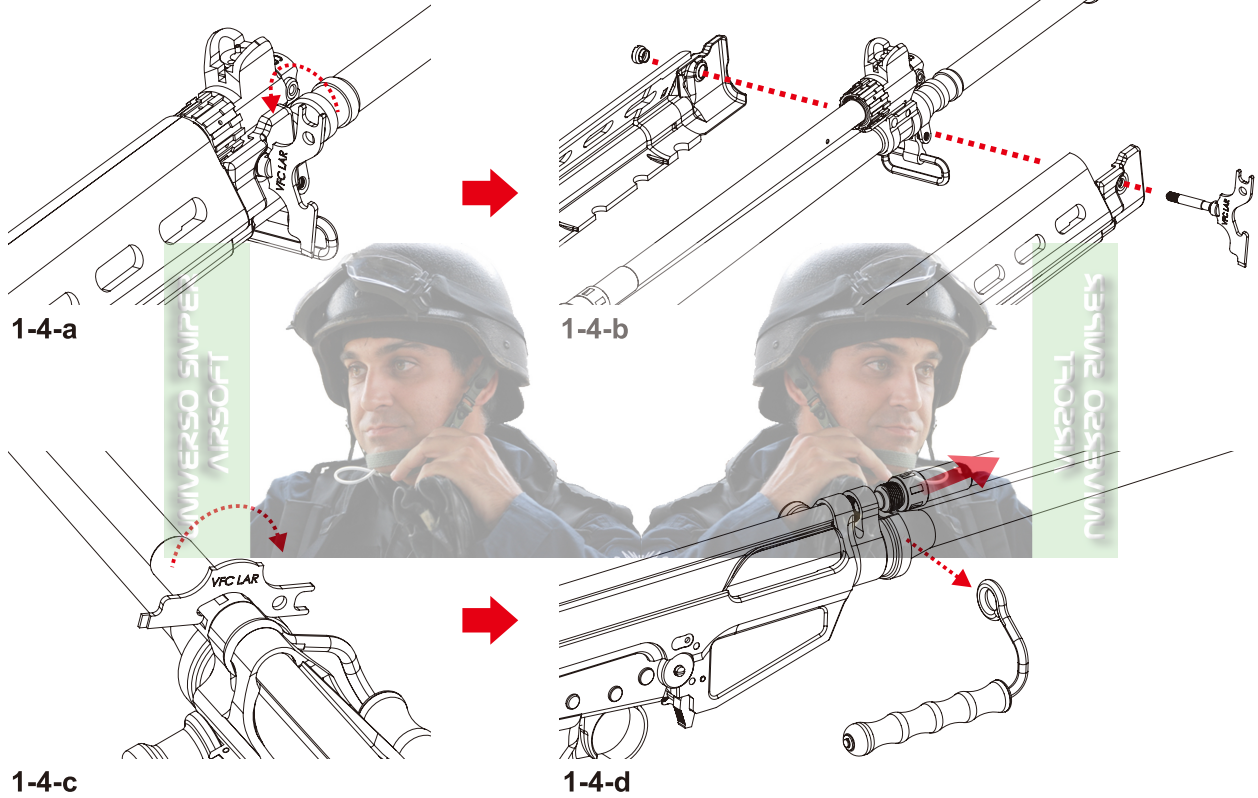

1-5 Magazine / 彈匣

If you'd like to enable the replica to fire (cycle and not lock back after each shot) without BBs loaded in the magazine, switch the Blank Firing Switch toward the rear of the magazine to disable the bolt lock feature.

如果你要進行無彈空擊操作，請將彈匣後定控制撥桿往後推固定，以取消彈匣上的槍機無彈後定機制。

NOTE:

Please push down the connecting plate (the plate shape part on magazine's rear topside) before pulling switch back, Force on the switch may cause parts damage.

向後推動彈匣後定控制撥桿前，請先將後搖臂(b-1)下壓再將彈匣後定控制撥桿(b-2)後推。避免錯誤操作與過度用力以免損壞零件。

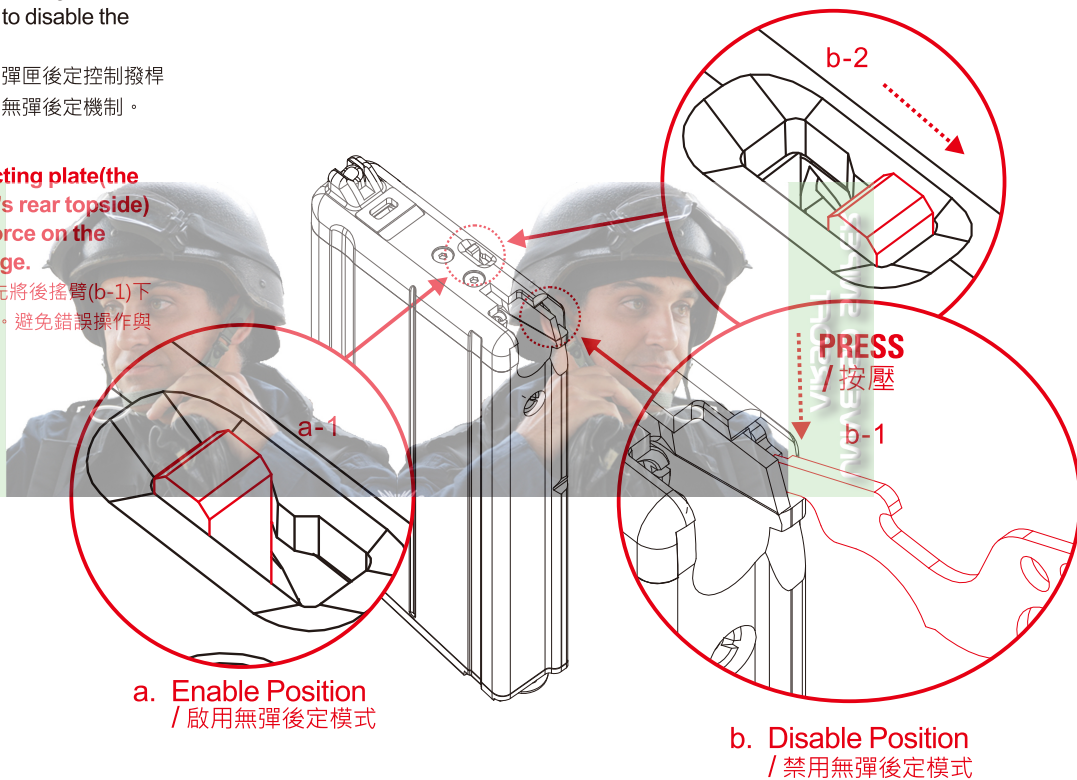

Chapter 2 - Operating Instructions / 章節2-使用說明

2-1 Checking Before You Fire / 射擊前檢查

a. Remove the Magazine / 卸下彈匣

Turn the fire selector to SAFE and press Magazine catch button to remove the magazine.

將射擊選擇鈕調為SAFE，並按下彈匣釋放鈕將彈匣卸下。

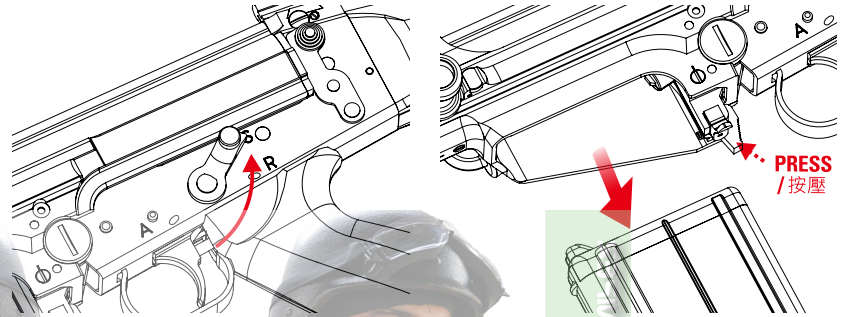

b. Cocking the Bolt / 槍機操作

Lock Bolt open, Pull Charging handle rearward to check that there is no BBs in the chamber, Return Charging handle to forward. Check to see if there are any BBs in the chamber, if so, remove them at this point. Check the Bolt and Charging handle to ensure free movement in the receiver.

將槍機拉柄後拉，並按下槍機釋放鈕將槍機固定在後。檢查槍膛內是否有殘餘BB彈，如果有請將BB彈取出，並將槍機拉柄復位。檢查槍機與槍機拉柄作動是否正常。

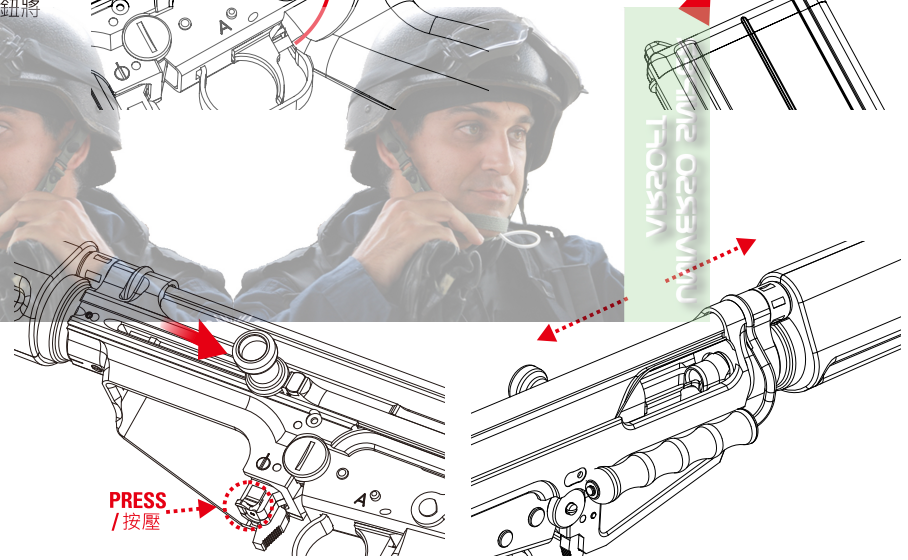

CAUTION: Do NOT Put Your Finger Into The Chamber, It's Dangerous.
注意：請勿將手指伸入槍膛內，造成危險。

c. Check the Selector Lever / 檢查射擊選擇鈕

Perform safety function check to ensure that safety selector lever works properly.

檢查並確認射擊選擇鈕是否正常作動。

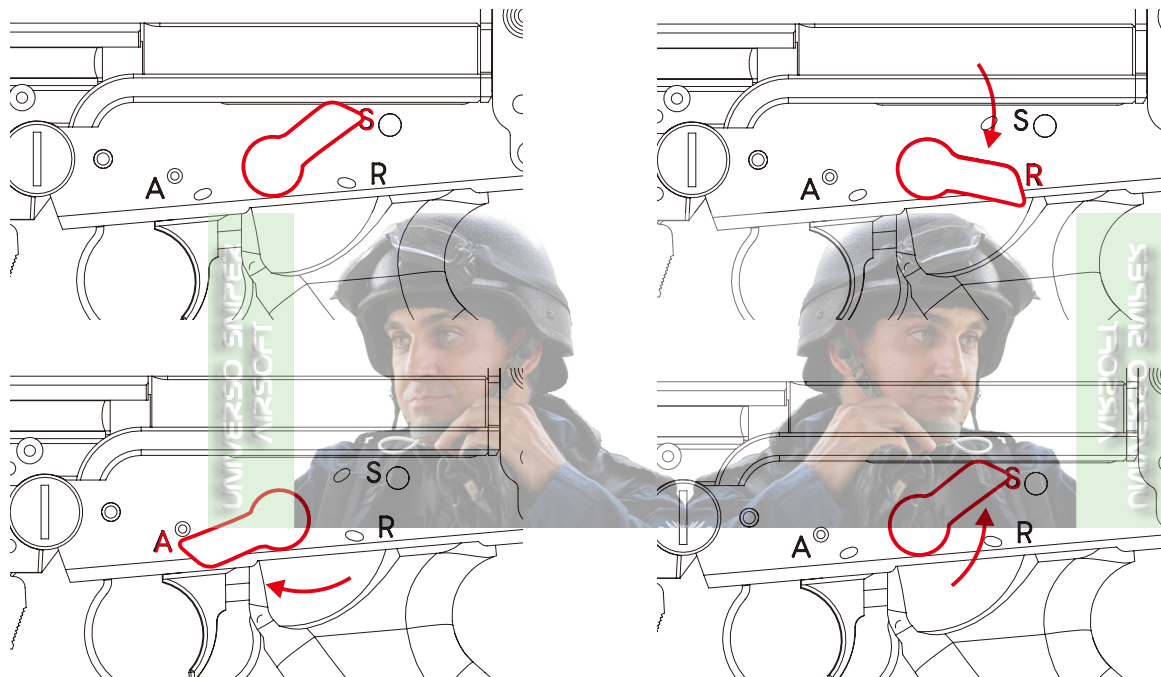

WARNING:

Always Point The Muzzle In A Safe Direction.

始終將槍口指向安全方向。

d. Safety Setting / 保險設置

Place safety selector lever on safe.

將射擊選擇鈕轉至保險位置。

2-2 Load the BBs / 裝填BB彈

a. BB Loader / BB彈填彈器

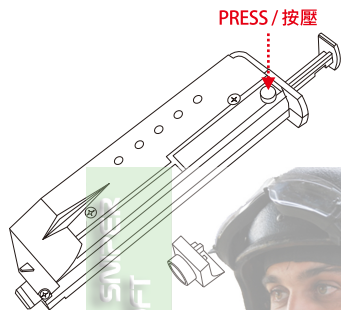

b. Insert the BBs to Loader / 將BB彈裝入填彈器



c. Load BBs / 裝填BB彈

Insert the BBs into the Magazine.
The maximum capacity is 28 round.
將BB彈裝入彈匣內，最大裝彈數為28發。

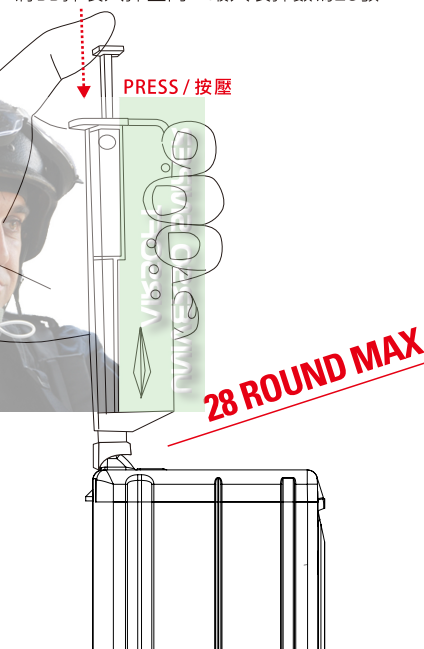

Always use the quality BBs for this airsoft gun, we will not be held responsible for any damage and accidents arising from using of bad quality BBs.

請使用原廠或品質良好的BB彈。若因使用劣質的BB彈造成玩具槍毀損，本公司不負相關保固之責任。



Diameter Larger Than 6mm
直徑大於6mm



No True Round Bbs
並非真圓



Both Halves Not Aligned
有模線痕跡



With Flash
有裂紋或破損



Used Or Soiled
已使用過或表面髒污

CAUTION: Do Not Force To Over Load.
注意：請勿裝填過量BB彈。

2-3 Filling the Gas / 填充瓦斯

a. Check the Nozzle / 確認彈匣灌氣口

Push the gas canister nozzle into the Filling gas nozzle.
Make sure the canister is in vertical position when charging.
將瓦斯罐接嘴對準並接上彈匣灌氣口，用力壓下開始填充。並確保彈匣灌氣口與瓦斯罐接嘴的垂直。

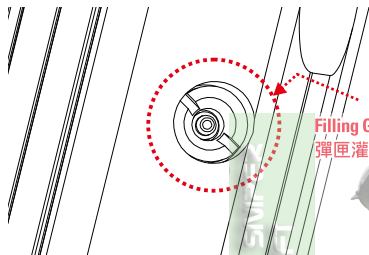

b. Filling the Gas / 填充瓦斯

For the better performance of the GBB rifle. Do not shoot the rifle right after charging the gas.
為了獲得最佳的效能，填充瓦斯完畢請勿立即開槍射擊。

CAUTION / WARNING

1. Keep hands and face at a safe distance from the escaping gas.
2. Escaping gas may cause icing.
3. Gas may explode if exposed to temperatures exceeding 50 °C.
4. Do not smoke, keep away from naked flames. The gas is highly inflammable.
5. Check canister for any cracks or leaks before using.
6. Do not boil canister.
7. Keep canister away from direct sunlight.
8. Do not leave canisters inside the vehicle.

1. 注意洩漏的瓦斯，避免肢體和臉部過於靠近。
2. 洩漏的瓦斯可能會導致結霜。
3. 如果暴露在超過攝氏50度的溫度下，可能導致瓦斯氣體過度膨脹或爆炸。
4. 瓦斯屬於高度易燃物質，填充瓦斯時，請勿吸菸並遠離火源及高溫處。
5. 使用前，請檢查瓦斯罐是否有裂紋或洩漏。
6. 請勿加熱瓦斯罐。
7. 瓦斯罐請避免陽光直射並存放於室內陰涼處。
8. 請勿將瓦斯罐留在車內。

c. Release the Gas / 釋放瓦斯

Please discharge the magazine by press the valve gently, for releasing residual gas.
請按下氣閥釋放鈕，釋放彈匣內殘餘的瓦斯。



2-4 Setting Magazine / 裝彈匣

Push magazine up in to magazine well. Make sure to set the magazine upwards and connect it firmly until a **CLICK SOUND** is heard.

將彈匣向上推入彈匣井內，確保彈匣插入方向正確。向上插入直到聽到**喀嗒聲**為止。

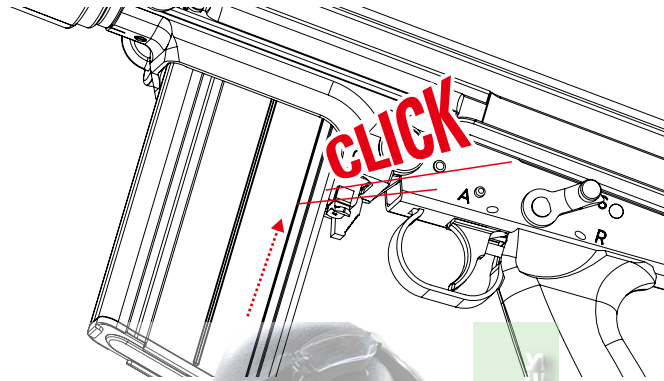

2-5 Ready to Fire / 射擊準備

a. Check the Chamber / 上膛

Open bolt to load the Bbs.

拉動槍機使槍枝上膛，無需後定。



b. Firing Mode Select / 射擊模式選擇

- To rotate the safety selector lever to the Fire Position.

- Pull the Trigger to fire.

- 將射擊選擇鈕轉至射擊位置。

- 扣動扳機射擊。

2-6 Release Bolt / 槍機釋放

Press the Button Release Bolt to Chamber.

按壓槍機釋放鈕釋放槍機，使槍機復位。

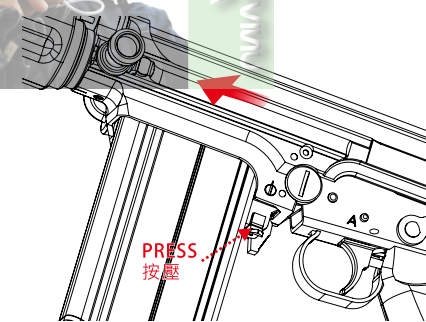
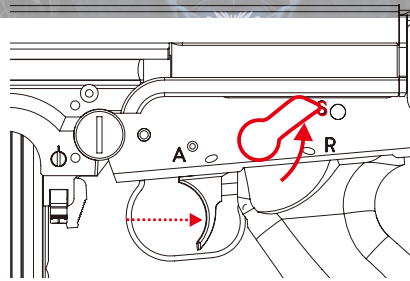
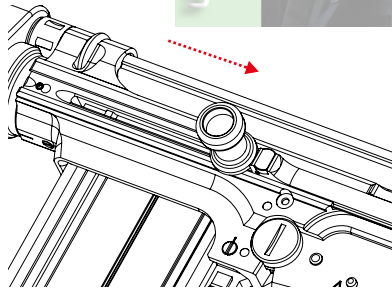

WARNING: Always Point The Muzzle In A Safe Direction.

警告：始終將槍口指向安全方向。

2-7 Variable HOP-UP System / HOP-UP調整系統

This HOP-UP system is adjusted by flat wrench or dedicated tool from VFC.

使用一字型扳手或是VFC原廠內附專用工具調整HOP-UP系統。

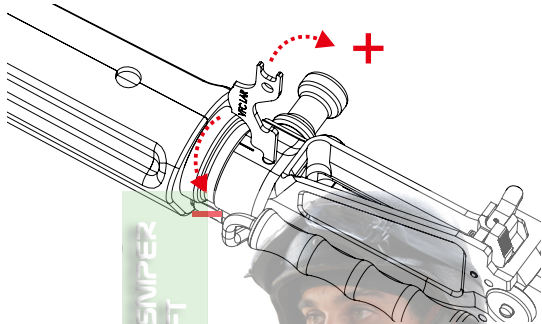

GuideHOP

Save time, Convenient and Fast

The LAR GBBR uses our new patented "GuideHOP" HOP-UP adjust system.

There is no need to disassemble the handguard or upper and lower receiver when you need adjust your HOP-UP. All you only need a flat wrench to adjust HOP-UP at upper.

You can adjust HOP-UP in anytime, anywhere, quickly and easily, without any disassembly.

省時、方便、快速

LAR採用VFC最新專利的"GuideHOP"彈道調整設計。

無需分解槍支，只需要使用一字型扳手即可在槍身處螺絲進行彈道調整。

您可以隨時隨地、快速方便的調整，無需任何拆解，大大減少因拆解所造成的不便與毀損。

2-8 Adjust HOP Effect / 調整HOP效果

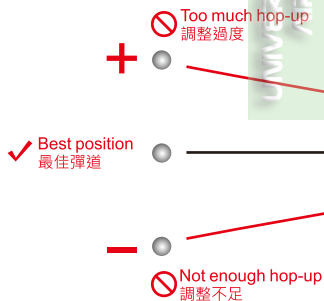

NOTE:

Never hold the gun sideways as BBs will curve right or left. This is due to the HOP UP system.

The best setting is where the BBs fly out horizontally and "flat". This will give you the best accuracy and range.

請勿翻轉或傾斜射擊你的槍，這會造成射出的彈道偏左或偏右，對於HOP UP系統設計，水平持握射擊是最好的射擊方式。

Chapter 3 - Maintenance / 章節3-保養

3-1 Field Stripping / 大部分分解

a. Remove the Magazine / 卸除彈匣

Press Magazine catch button and remove the Magazine.

按下彈匣釋放鈕將彈匣卸下。

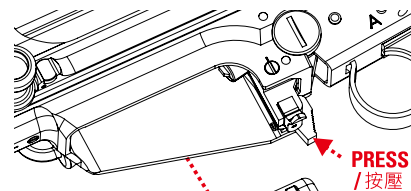

b. Safety setting / 保險設置

Place safety selector lever on safe.

將射擊選擇鈕轉至保險位置。



c. Frame Locking Lever / 槍身卡榫連動桿

Press the Trigger Frame-body Lock Lever on the left side of the receiver, hold the barrel in one hand and butt stock in the other. Pull downward on the buttstock side to separate upper and butt-trigger group.

將槍身卡榫連動桿向後推，分離上下槍身。

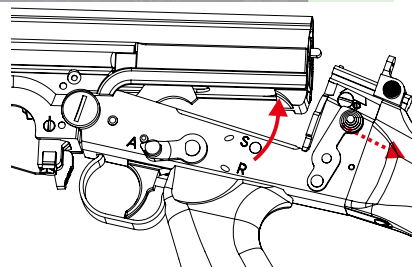

d. Cover of upper receiver / 上機匣蓋

To remove the cover from the receiver.

將上機匣蓋如圖抽出。

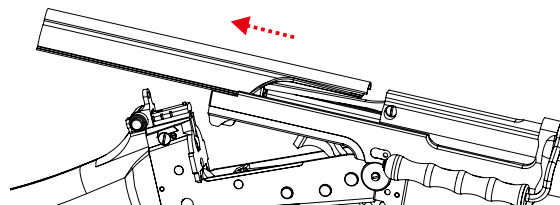

e. Remove the Breech Block Limiter / 卸除槍機限位塊

Pull back the Breech block limiter.

- If you need to assemble, please assemble according to the finger installation direction directly above the stopper.

向後拉出槍機限位塊。

•請注意需要組裝時，槍機限位塊正上方有一個組裝方向標示。

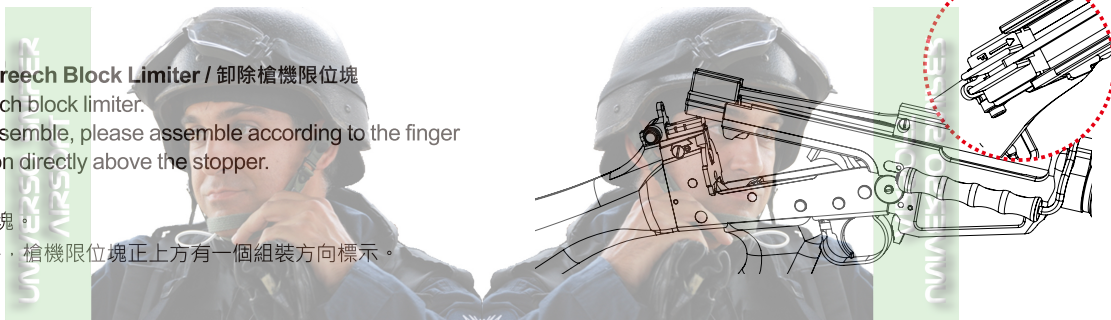

f. Remove the Breech Block Assembly / 卸除槍機組

Pull out the breech block assembly.

向後拉出槍機組合件。

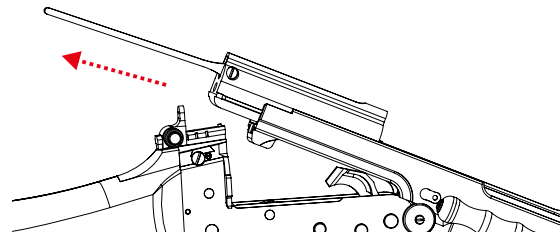

d. Unscrew the Hinge Pin Locking Screw / 旋開下槍身結合螺絲

– Use the included tool to unscrew the Hinge Pin Locking Screw.

如圖使用VFC專用工具旋開下槍身結合左側螺絲。

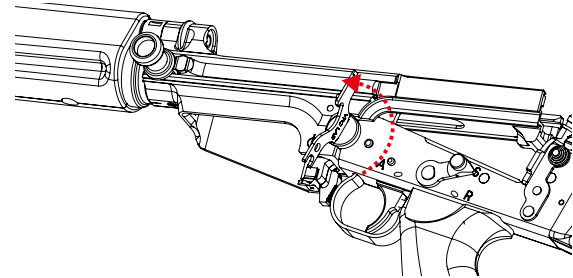

e. Remove the Hinge Pin Locking Screw / 卸除下槍身結合螺絲

Remove the Hinge Pin Locking Screw from the left side of the receiver.

卸除槍身結合左側螺絲。

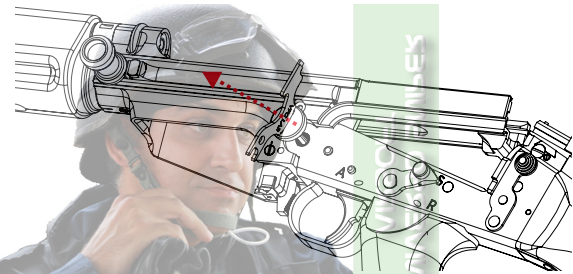

f. Push out the joint pin / 卸除下槍身結合螺絲

Push out the joint pin from the right side of the receiver.

卸除槍身結合右側螺絲，並將上下槍身分離。

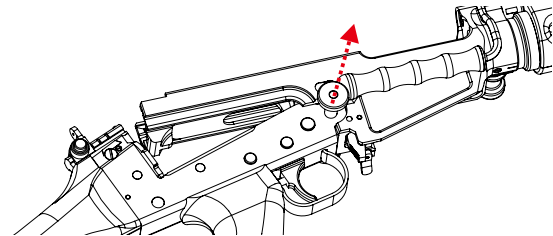

3-1 Field Striping / 大部分解

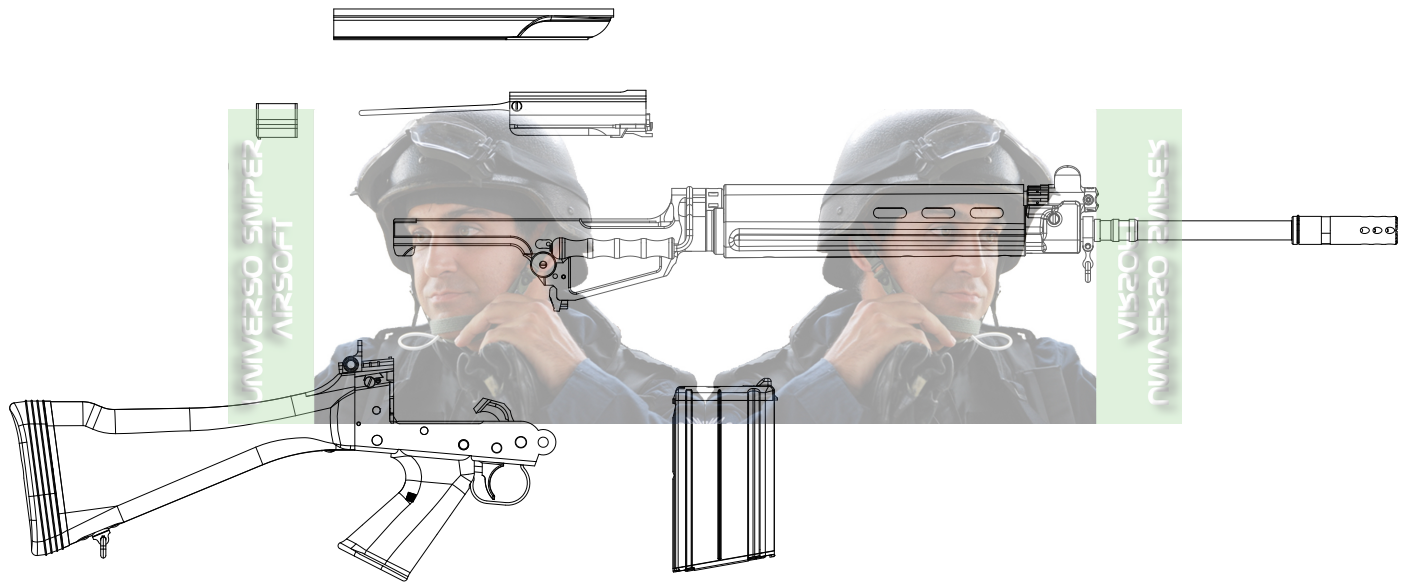

3-2 Cleaning and Maintenance / 清潔與保養

a. Lower Receiver / 下槍身

Lightly lubricate all moving parts inside the lower receiver.

些微潤滑下槍身內的可動部件。

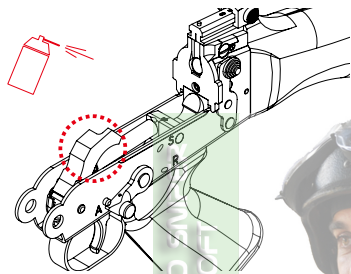

b. Bolt Assembly / 槍機組件

Use silicone oil lightly lubricate all contact area.

使用矽油將所有可接觸區域做些微潤滑。

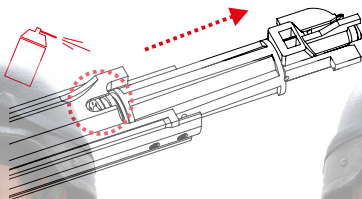

c. Buffer Assembly / 緩衝機組件

Push the buffer assembly back first, clean all areas and use silicone oil lightly lubricate all contact area.

將緩衝機組件輕壓使其後退，並使用矽油將所有可接觸區域做些微潤滑。

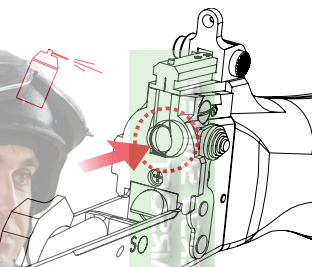

d. Magazine / 彈匣

Clean all areas of fouling, metal debris and dirt.

清潔所有區域並清除污垢與金屬碎屑。

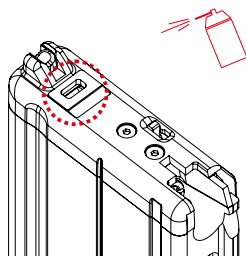

e. Inner Barrel / 槍支內管

Use an airsoft cleaning rod to clean the inner barrel.

使用通槍條清潔槍支內管。

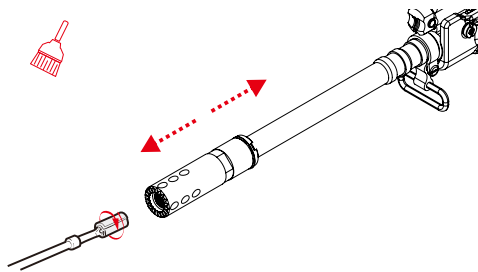

CAUTION:

Use silicone oil the lubrication only. Do not use WD-40 or any petroleum based lubricant.

僅使用矽油潤滑。
請勿使用WD-40進行潤滑。

3-4 Troubleshooting / 故障排除

Symptom / 徵狀	Cause / 原因	Action / 解決方式
No operation at all. 操作沒有反應	<ol style="list-style-type: none"> 1. No Gas in Magazine. 彈匣內沒有瓦斯。 2. Selector lever on safe. 射擊選擇鈕在保險位置。 3. Not loaded. 未上膛。 4. The Magazine is in low temperature. 彈匣溫度過低。 5. The pressure inside the Magazine is too high. 彈匣內壓力過高。 	<ol style="list-style-type: none"> 1. Unload the Magazine and filling the Gas. 卸下彈匣並填充瓦斯。 2. Turn the selector lever on semi/full auto sites. 將射擊選擇鈕轉至半自動/全自動射擊模式。 3. Pull the Charging handle, loading the rifle. 拉動槍機拉柄，使步槍上膛。 4. After extended or rapid fire, the Magazine will be in low temperature. Please, unload the Magazine until the Magazine temperature rises to normal. 射擊後，彈匣將處於低溫狀態。請卸下彈匣，靜待彈匣恢復常溫。 5. Do not use Gas which pressure is surpassed 12 Kg/cm .² 請勿使用壓力高於12 Kg/cm 的瓦斯。
Magazine leak. 彈匣漏氣	<ol style="list-style-type: none"> 1. O ring aged. O環老化。 2. O ring broken. O環斷裂。 3. Charging valve broken. 彈匣灌氣口損壞。 	<ol style="list-style-type: none"> 1.2.3. Purchase the replacement part at your dealer or from VFC. 向經銷商或VFC購買替換零件。
The recoil force decreases. 後座力變小	<ol style="list-style-type: none"> 1. The Magazine is in low temperature. 彈匣溫度過低。 2. The gas pressure is insufficient. 瓦斯氣體壓力不足。 3. Lubrication insufficiency. 潤滑不足。 4. Bolt O ring broken. 槍機O環破損。 	<ol style="list-style-type: none"> 1. After running fire, the Magazine will be in low temperature. Please, unload the Magazine until the Magazine temperature rise to normal. 射擊後，彈匣將處於低溫狀態。請卸下彈匣，靜待彈匣恢復常溫。 2. Unload the Magazine and refill the gas. 卸下彈匣並重新填充瓦斯。 3. The moving part needs lubrication. 可動部件需要潤滑保養。 4. Purchase the replacement part at your dealer or from VFC. 向經銷商或VFC購買替換零件。
The BB trajectory isn't straight or accurate. 彈道不穩定	<ol style="list-style-type: none"> 1. Too much hop setting. hop旋鈕調整過度。 2. Inner Barril or Hop parking contaminated by oil or dirt. 槍支內管或HOP橡皮內有灰塵或油污。 3. Worn or damaged hop parking. HOP橡皮磨損或毀壞。 4. Improper or too large size BB bullets. 使用不合適或太大的BB彈。 	<ol style="list-style-type: none"> 1. Gradually return adjustment lever towards normal. 漸趨調節使彈道平穩正常。 2. Clean the oil or dirt. 清潔灰塵或油污。 3. Purchase the replacement part at your dealer or from VFC. 向經銷商或VFC購買替換零件。 4. Use the quality BBs. 使用優質BB彈。

If you have any other issues, please contact your dealer, or write us at service@vegaforce.com.tw
 如果您有其它問題，請向您購買的經銷商聯繫或寄電子郵件至我們公司信箱service@vegaforce.com.tw

1KG
PACK

SUPREME PRECISION GRADE BBs

For Your Gas Rifle And Pistol 100% Made In Taiwan



Plastic Series

Diameter
5.95 mm
± 0.01mm



CERTIFICATIONS:

Biodegradable Test Report ISO 14855-1 in connection with DIN EN 13432
Certified EN71 part 3:2013
Compliant with ASTM D-6400-99 "Standard Specifications for Compostable Plastics"



BIO Series

UNIVERSO SIMPER
AIRSOFT

UNIVERSO SIMPER
AIRSOFT



VegaForce[®]Company
www.vegaforce.com



8F., No.609, Sec. 1, Wanshou Rd., Guishan Dist.,
Taoyuan City 333, Taiwan (R.O.C.)
Phone: +886-2-8200-6630
Fax: +886-2-8200-6631
e-Mail: service@vegaforce.com.tw