

使用說明書

HANDLING CAUTIONS AND INSTRUCTION MANUAL

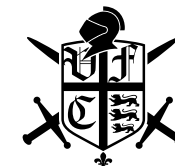

VegaForce™ Company
Automatic Electric Rifle

對象年齡十八歲以上 User restricted to 18 years of age or older

4F-6, No.14, Xiwei St., Sanchoung City, Taipei County 241, Taiwan
TEL : 886-2-2287-9427 FAX : 886-2-2287-9450
Email : gb.tech@msa.hinet.net

注意
WARNING

使用前請務必詳讀此說明書
Always read through this manual before operation.

目錄

警語	WARNING	2
SR-15/16 簡介	PROFILE	3
各部名稱	COMPONENT NAME	7
選擇鈕、手動保險說明	SELECTOR LEVER & SAFETY SETTING	8
電池的安裝	SETTING BATTERY	9
彈匣的安裝	SETTING MAGAZINE	10
準星與照門的調整	SETTING THE FRONT SIGHTS AND REAR SIGHT	11
可動部的說明	MOVABLE PARTS	13
射擊	FIRING	16
可變Hop-Up系統的說明	VARIABLE HOP-UP SYSTEM	18
故障內容自我診斷	TROUBLE CLINIC	21
分解圖、零件表	PARTS LIST	23
關於售後服務	AFTER SERVICE	25
相關周邊產品	ACCESSORIES	26



KAC STONER RIFLE SERIES
SR15 / 16 E3 IWS

警告

在操作本產品之前，請務必詳讀此操作手冊

- 請務必帶上護目鏡等護眼用具。
- 請勿射擊人或動物。
- 隨意用BB槍開玩笑可能會觸及法律。
- 嚴禁望向槍口。
- 請將槍口朝向安全的地方。
- 射擊時無論遠近，隨時確認射擊區內是否有行人或車輛經過。
- 避免任意不經意地扣處扳機。
- 除非完成射擊準備，否則切勿將手指放入扳機。
- 不用或搬運時，請務必放置於槍盒等容器內。
- 請存放在兒童拿不到的地方。
- 禁止擅自改造或加強槍枝結構。
- 非射擊時請將選擇鈕切換到保險位置。

Warning!

Always read through this manual before operation.

- Always wear eye protective gear .
- Never aim or shoot a person or animal as the target.
- You may be punished if you are shooting for a practical joke.
- Never look into the gun muzzle.
- Always direct the muzzle towards a safe direction.
- Never shoot the air gun at places where people and cars pass cross.
- Avoid pulling the trigger carelessly.
- Please put away your fingers from the trigger, except when you are Ready to shoot a target.
- Always put the gun in a case or bag when you are carrying it.
- Store the gun at places out of reach by children.

警語

簡介

各部名稱

選擇鈕

電池安裝

彈匣安裝

準星照門

動部說明

射擊

Hop-Up

配件裝著

故障診斷

分解圖表

售後服務

周邊產品

- 警語
- 簡介**
- 各部名稱
- 選擇鈕
- 電池安裝
- 彈匣安裝
- 準星照門
- 動部說明
- 射擊
- Hop-Up
- 故障診斷
- 分解圖表
- 售後服務
- 周邊產品

KAC SR-15/16 E3 IWS series

90年代中期，位於佛州的奈特軍火公司（簡稱KAC）成功的贏得了美國軍方的SOPMOD計劃，以其所開發的RIS軌道介面系統，提供一個裝著各種瞄具、槍燈等戰術配件的標準平台，也開啟模武器系統模組化的新紀元。

而隨著戰場的淬鍊，美軍對於軌道介面系統亦提出新的需求。為了符合美軍的需求，奈特軍火公司亦不斷改進，演進出最新的URX系統。URX系統最主要的特色在於上軌道與M4上機匣的延伸成為連續的同一平面，不僅方便瞄具的裝設，也不會增加高度影響瞄準。同時，URX採用自由浮動式設計，軌道護木不接觸槍管，可增加準確度。此外，URX的下軌道亦可輕易的拆卸，以方便維護工作或是M203榴彈發射器的裝著。在此同時，KAC亦推出IWS整合型武器系統的概念，把原本需要再另外加裝的備用摺疊準星、快拆背帶環座等配件，與URX整合，以增進整個武器系統的戰鬥與戰術能力。

KAC最新推出的SR15/16 E3 IWS系列突擊步槍，就是根據整合型武器系統的概念演化而成。所謂的E3指其所使用的槍機，加強了可靠性、耐用性與維護性三個構面，而控制介面上，裝設了方便左右撇子射手所使用的雙邊連動保險鈕、雙邊連動彈匣卡榫、以及雙邊連動的槍機卡榫等，讓射手在戰鬥時能快速更換彈匣，爭取時間，同時也掌握生死。

正如同騎士手上的寶劍，新一代的KAC SR15/16 E3 IWS，整合了戰鬥與操控元件的進化型步槍，儼然已成為現代戰士手上的神兵利器。

KAC Sr15 E3 IWS	資料	KAC Sr16 E3 IWS
16"	槍管長	14.5"
33"(36.25")	全長	31.75" /30"
6.75 lbs	重量	61bs12oz
5.56 mm NATO / .223	口徑	5.56 mm NATO / .223
30 Rounds	裝彈數	30 Rounds

VFC SR-15/16 E3 IWS Series

在M4眾多衍生家族中，VFC挑選了最新、最具戰鬥力，最能代表尤金史東納設計魔力的Knight SR15/16 E3 IWS作為M4系列電動步槍的第二彈。

秉持著超高細緻度與極致像真度的信念，VFC的SR15/16 E3 IWS絕對是眾多M4中的頂級之作。首先，為了不辜負Knight的IWS設計理念，VFC的設計團隊花了許多心思，實現了電動M4難以做到的雙邊連動保險、雙邊連動彈匣卡榫以及雙邊動作的槍機釋放鈕等機構，使每個槍主，不論是左撇子射手或是右撇子射手，都可以輕易且快速的完成這把槍。同時，在中型URX軌道與下槍身，總共整合了7個快拆槍背帶扣環座，方便搭配身上的戰術裝備或是依照個人的使用習慣來調整持槍姿勢。而不論是整合了折疊準星與快拆背帶環座的SR15，或是搭配自動彈跳式準星的SR16，各個細節都是無懈可擊！

材質方面，嚴選高級的鋁合金與鋼材，輔以精密的CNC機械銑削，加上軍規等級的表面處理，顯現出凌駕真品的質感。整把槍因採用大量的金屬而顯得堅固扎實，但講究高度的平衡手感，因此不失輕巧靈活。塑膠握把與槍托則是軍規標準的尼龍加纖，最值得注意的地方，是握把的厚度，比市面上其他電槍都薄，握感一流。

內部機構方面，也進化成8mm強化型高精度齒輪箱，採用專家等級的鋼製軸承，高硬度鋼製齒輪，與真品GLOCK同級的PC塑料製成的超耐磨強化活塞，並搭配滾珠培林尾頂桿，歷經12V汽車電瓶嚴格的測試，可使用市售鋰電池。

而專利獨特設計的槍機後定機構，方便Hop-up的調整，也能享受槍機上膛的樂趣。堪稱超凡的配置，表現出卓越的性能。

VFC Sr15 E3 IWS	資料	VFC Sr16 E3 IWS
16"	槍管長	14.5"
835mm/918mm	全長	800mm/880mm
2880g	重量	2850g
6mmBB	口徑	6mmBB
300 Rounds	裝彈數	300 Rounds
85m/sec	槍口初速	85m/sec

- 警語
- 簡介**
- 各部名稱
- 選擇鈕
- 電池安裝
- 彈匣安裝
- 準星照門
- 動部說明
- 射擊
- Hop-Up
- 故障診斷
- 分解圖表
- 售後服務
- 周邊產品

- 警語
- 簡介
- 各部名稱
- 選擇鈕
- 電池安裝
- 彈匣安裝
- 準星照門
- 動部說明
- 射擊
- Hop-Up
- 故障診斷
- 分解圖表
- 售後服務
- 周邊產品

KAC SR-15/16 E3 IWS series

In mid 90s, Knight Armament Company (KAC) in Florida got the SOPMOD (Special Operations Peculiar Modification) project from US DOD, they use their RIS (Rail Interface System) to provide a standard system which allows the various tactical attachment such as rail-mounted devices, flashlight... etc; it also brings a new epoch of modular weapon system.

According to the response from the battle field, America's Army have new needs for Rail Interface System (RIS). To match the needs of America's Army, KAC keep upgrading to make the newest URX (Upper Receiver Extending) system. The URX provides several advantages. It provides an uninterrupted rail and does not increase the height of the rail over the barrel, which may cause sighting problems for attached optics. With the URX installation, the barrel is free-floated, allowing for increase accuracy. Besides, URX lower rail could be easier removed to mount M203 grenade launcher or make maintenance convenient.

At the mean time, KAC also came out the concept of IWS (Integrated Weapon System), which make URX integrated with some accessory such as spare folding front sight, quick detached sling mount...etc. to increase the combat and tactical ability in the entire weapon system.

KAC newest released SR15/16 E3 IWS series rifle is the evolution according the integrated weapon system concept to manufacture. E3 means the E3 bolt has been enhanced more reliability, durability, and maintainability; establishing the ambidextrous function in safety selector, magazine catch, and bolt catch...etc, design for both left-hand and right-hand shooters; these are could be able to quick drop/reload magazine and attain tactical dominance at the combat field.

Just like the sword on the hand of the knight, new KAC SR15/16 E3 IWS is an integrated rifle with combat and controlling components; it is becoming a newest impressive weapon for soldier at the present day.

KAC Sr15 E3 IWS	Data	KAC Sr16 E3 IWS
16"	Barrel	14.5"
33"(36.25")	Lenght	31.75" /30"
6.75 lbs	Weight	61bs12oz
5.56 mm NATO / .223	Caliber	5.56 mm NATO / .223
30 Rounds	Capacity	30 Rounds

VFC SR-15/16 E3 IWS Series

VFC has selected the Knight SR15/16 E3 IWS, the latest, most combat effective and the epitome of Eugene Stoner's design magic as VFC's second entrant into the M4 series.

Meticulously crafted, the SR15/16 E3 IWS stands out among VFC's many M4 series rifles. VFC designers, striving to meet the exacting standards of Knight IWS design, have built in ambidextrous function at safety selector, magazine catch, and bolt catch...etc, perfect design for both left-hand and right-hand shooters allowing to easy and rapid operation.

The VFC SR15/16 E3 IWS also features a total of seven quick-release sling swivels on the along the middle size URX rail and lower receiver allowing for a number of slinging configurations to accommodate other tactical gear and personal carrying preferences. No matter the integrated front folding sight and sling swivel mount in the SR15 or the auto flip up type front sight in the SR16, every detail is no compromised.

Regarding the material, the VFC SR15/16 E3 IWS is made from high quality aluminum alloy and steel, and process with CNC machining and military standard finish. The resulting product has the exact look and feel of the real steel. The many metal components of the SR15/16 E3 IWS give it a solid but well balanced, easily maneuverable feel. The grip and carne type stock are made of military grade nylon with fiber. Perhaps the most notable feature of the SR15/16 E3 IWS is its unique grip, more slender than other electric rifles on the market.

Regarding the material, the VFC SR15/16 E3 IWS is made from high quality aluminum alloy and steel, and process with CNC machining and military standard finish. The resulting product has the exact look and feel of the real steel. The many metal components of the SR15/16 E3 IWS give it a solid but well balanced, easily maneuverable feel. The grip and carne type stock are made of military grade nylon with fiber. Perhaps the most notable feature of the SR15/16 E3 IWS is its unique grip, more slender than other electric rifles on the market.

VFC Sr15 E3 IWS	Data	VFC Sr16 E3 IWS
16"	Barrel	14.5"
835mm/918mm	Lenght	800mm/880mm
2880g	Weight	2850g
6mmBB	Caliber	6mmBB
300 Rounds	Capacity	300 Rounds
85m/sec	Cycle Rate	85m/sec

- 警語
- 簡介
- 各部名稱
- 選擇鈕
- 電池安裝
- 彈匣安裝
- 準星照門
- 動部說明
- 射擊
- Hop-Up
- 故障診斷
- 分解圖表
- 售後服務
- 周邊產品

1 各部名稱 COMPONENT NAME

SR-15 E3 IWS

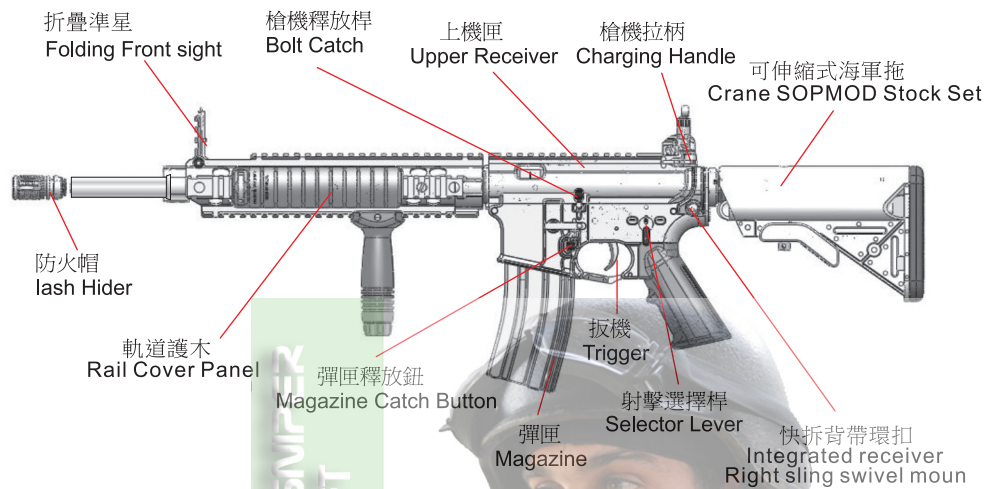

SR-16 IWS

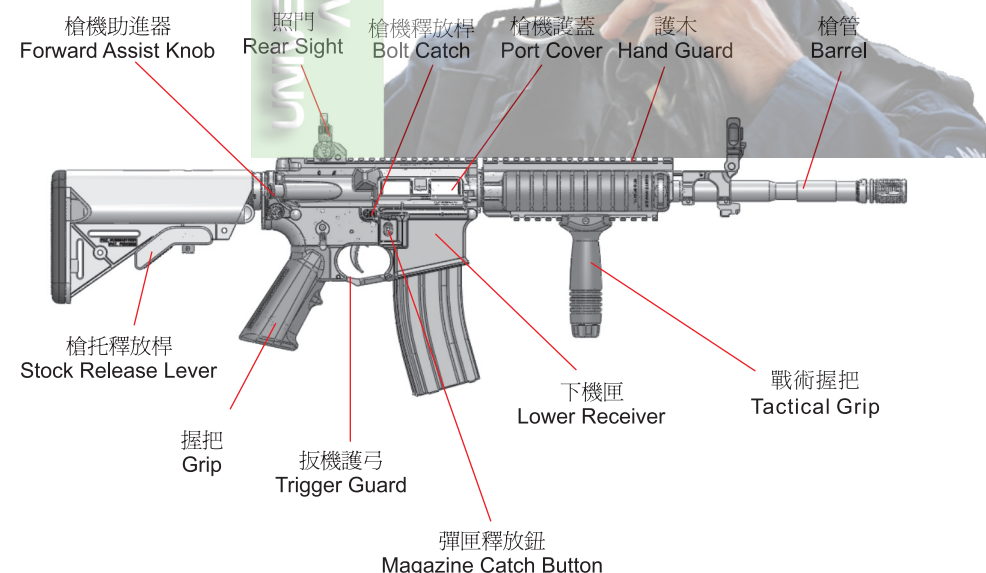

2 保險說明 SELECTOR LEVER & SAFETY SETTING

※選擇鈕未扳至正確位置有可能會導致射擊模式發生錯誤。
 ※Be careful not to catch your fingers in the moveable parts.

保險(無法扣動扳機)
 不射擊或一般存放時，務必將選擇鈕設定至保險位置。

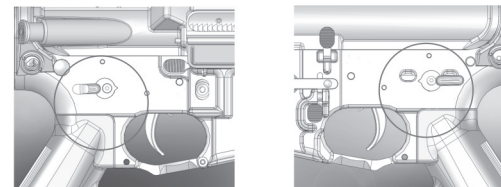

關保險

半自動(單發)
 扣一次扳機只會發射一顆子彈。

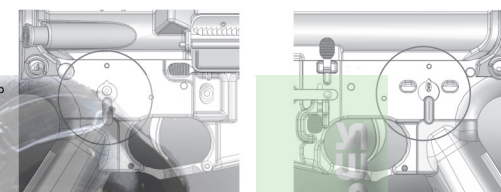

全自動

全自動(連發)
 扣著扳機不放會連續發射子彈。

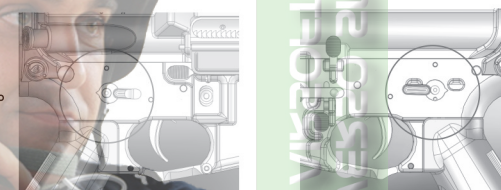

半自動

警告 · 注意

- 請勿一邊扣動扳機一邊扳動選擇鈕，否則將導致動作不良，或發生意外。
- 在關保險狀態，強制扣動有可能會導致故障。
- **WARNING · CAUTION**
- Never operation the Selector while pulling the trigger. Otherwise, malfunctions are possible, resulting in accidents.
- Pulling the trigger with the Selector being set to safe may damage the gun.

右側 Right

左側 Left

Safety Setting (The trigger can not be pulled)
 Always set the lever to the Safety position when you are not firing the gun or during storage.

Full Auto (Automatic Shot)
 The gun will fire automatically while the trigger remains pulled.

Semi Auto (Single Shot)
 The gun will fire one shot each time the trigger is pulled.

- 警語
- 簡介
- 各部名稱**
- 選擇鈕
- 電池安裝
- 彈匣安裝
- 準星照門
- 動部說明
- 射擊
- Hop-Up
- 故障診斷
- 分解圖表
- 售後服務
- 周邊產品

- 警語
- 簡介
- 各部名稱
- 選擇鈕**
- 電池安裝
- 彈匣安裝
- 準星照門
- 動部說明
- 射擊
- Hop-Up
- 故障診斷
- 分解圖表
- 售後服務
- 周邊產品

3 電池的安裝 Setting the Battery

※安裝電池前先卸下彈匣。

- 警語
- 簡介
- 各部名稱
- 選擇鈕
- 電池安裝**
- 彈匣安裝
- 準星照門
- 動部說明
- 射擊
- Hop-Up
- 故障診斷
- 分解圖表
- 售後服務
- 周邊產品

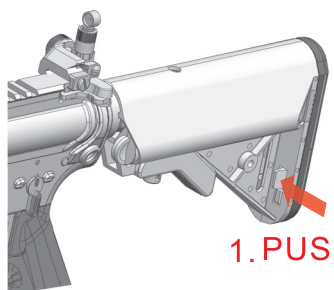

拆下槍托底板
Remove the butt stock plate

1. PUSH

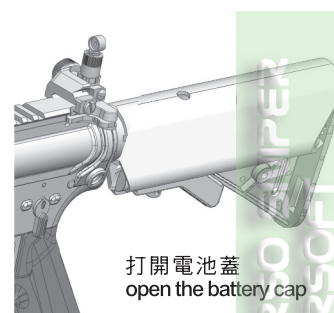

打開電池蓋
open the battery cap

2. PULL



3. 電池

裝上電池
insert the battery

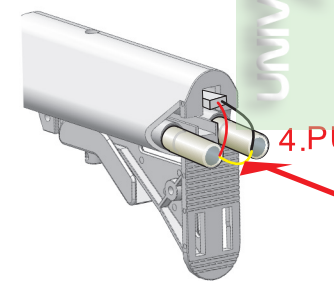

4. PUSH

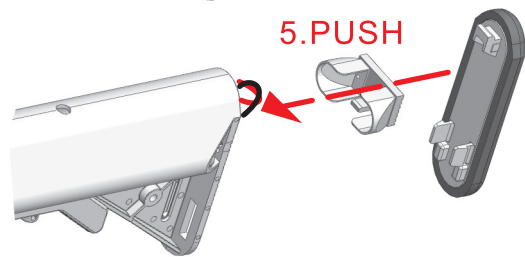

5. PUSH

依序裝回槍托底板
close the cap and butt stock plate
to finish battery installing

警告·注意

- 電池必須先行充電完畢
- 電池安裝時，請將槍口朝向安全的位置，並將選擇鈕設定於保險位置。

WARNING · CAUTION

- Conduct operations hereafter charging the battery
- Direct the muzzle Towards a safe direction and set the selector lever to the Safety position.

BATTERY
9.6V~12V Nimh or 11.1V Li-Poly
Battery Recommended.

4 彈匣的安裝 Setting the Magazine



右側 Right

左側 Left

1. 按下彈匣卡榫取下彈匣
Press the magazine release lever to remove the magazine.



2. 將6mmBB彈裝填入彈匣，彈匣的最高容量為300發
Insert 6mm BB bullets into the magazine.
The magazine is capable of containing 300 bullets.



右側 Right

左側 Left

警告·注意

- 請使用VFC製BB彈。若因使用其他品質粗劣之BB彈所造成的故障，本公司一概不負保固責任。

WARNING · CAUTION

- Always use the VFC BB bullet for this air gun. We will not be held responsible for any damage and accidents arising from use of bad quality bullets supplied by other manufacturers.

3. 依序插入彈匣：
a. 依序插入彈匣
b. 垂直卡入
c. 確認彈匣卡榫確實卡住彈匣

Always set the magazine upwardly
First, align to the groove shown by an arrow and press in the rear of the magazine.

- 警語
- 簡介
- 各部名稱
- 選擇鈕
- 電池安裝**
- 彈匣安裝
- 準星照門
- 動部說明
- 射擊
- Hop-Up
- 故障診斷
- 分解圖表
- 售後服務
- 周邊產品

- 警語
- 簡介
- 各部名稱
- 選擇鈕
- 電池安裝
- 彈匣安裝
- 準星照門**
- 動部說明
- 射擊
- Hop-Up
- 故障診斷
- 分解圖表
- 售後服務
- 周邊產品

SR-15 E3 IWS

Integrated Micro-adjustable Folding Front Sight

1. 按下按鈕
press the button

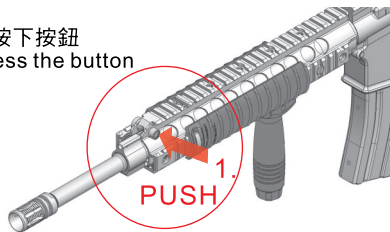

2. 摺疊準星會自動彈起
Folding Front Sight will
flip up automatically

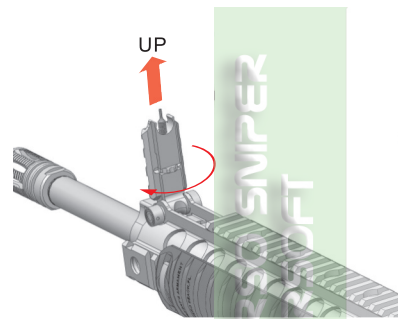
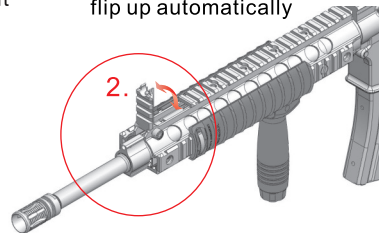

順時針旋轉上升
Turn it Clockwise will to raise up



逆時針旋轉下降
Turn it to lower down

SR-16 E3 IWS

SR16準星調整旋鈕
SR16 Setting the Front Sight

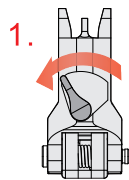

開啟
OPEN

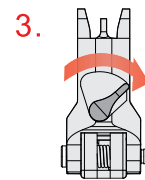
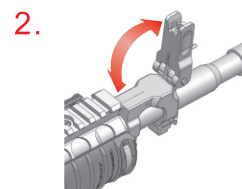

鎖住
LOCK

Knight 600m Rear Sight

200-600 Meter Micro-adjustable Folding Front Sight

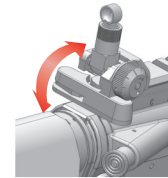

照門上下的調整：
轉動照門上方的上下調整旋鈕，
就可以調整照門的上下位置。

Elevation adjustment:
Turn the elevating knob for elevation adjustment.
Clockwise: Long distance
Anticlockwise: Short distance

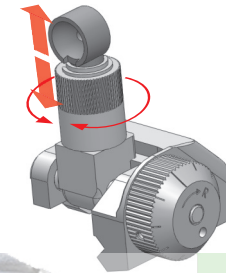

警告 · 注意

● 旋轉照門時請小心
勿被夾傷。

WARNING · CAUTION

● Be carefully and
don't get hurt when
turning the rear
sight.



600M照門左右風偏的調整：
轉動照門右側的風偏旋鈕，
就可以調整照門的左右位置。

600M rear sight windage adjustment:
Turn the windage knob for windage adjustment.
Forward: Move the sight to right.
Backward: Move the sight to left.

Knight Type 300M Rear Sight

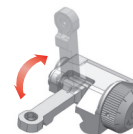

300M照門左右風偏的調整：
轉動照門右側的風偏旋鈕，
就可以調整照門的左右位置。

300M rear sight windage adjustment:
Turn the windage knob for windage adjustment.
Forward: Move the sight to right.
Backward: Move the sight to left.

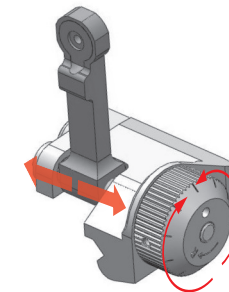

6 可動部的說明【6-1】：伸縮式海軍槍托 Crane SOPMOD Stock Set

【6-3】：軌道護片 Rail Cover Panel

- 警語
- 簡介
- 各部名稱
- 選擇鈕
- 電池安裝
- 彈匣安裝
- 準星照門
- 動部說明**
- 射擊
- Hop-Up
- 故障診斷
- 分解圖表
- 售後服務
- 周邊產品



警告·注意

- 操作伸縮托時，請小心勿被夾傷。

WARNING · CAUTION

- Be carefully and don't get hurt when using the stock.

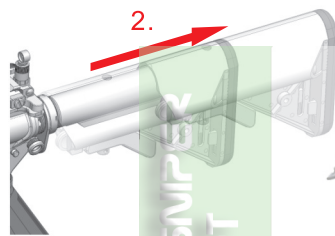

1. 押著槍托釋放桿不放。
 2. 將槍托向後拉。
 3. 調整槍托位置，有五段可調整。
1. Push the release lever to unlock.
 2. Pull the stock.
 3. Adjust the position of stock(5 positions).

【6-2】 Knight type 快拆槍背帶環 Knight type Push-Button Swivel

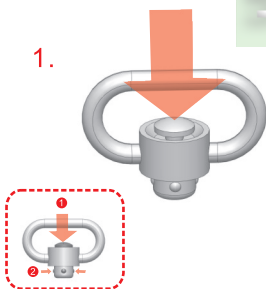

按壓扣環中間按鈕，可將快拆背帶環組裝或拆除。
Pressing the central button of the buckle to release or install the QD sling swivel.



快拆背帶環有七個安裝處。QD sling swivel has seven position to install.

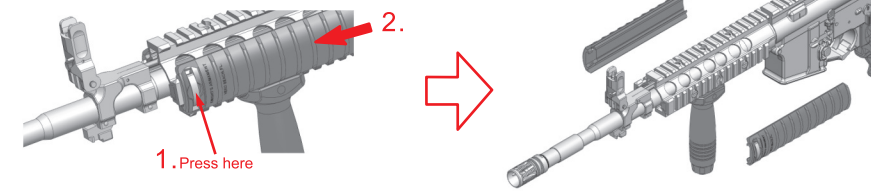

1. 將軌道護片前方的彈簧片向中間按壓。
 2. 同時將軌道護木往前推，即可取出。
1. Pressing the front clips of the rail cover panel toward the center.
 2. simultaneously, push the rail cover panel forward and it can be taken out

【6-4】：戰術握把 Forward Pistol Grip

戰術握把下方旋鈕：方向向下，順時針旋轉即可將握把取下。

The knob under the forward pistol grip face down the grip, twist clockwise and then the grip can be taken out.

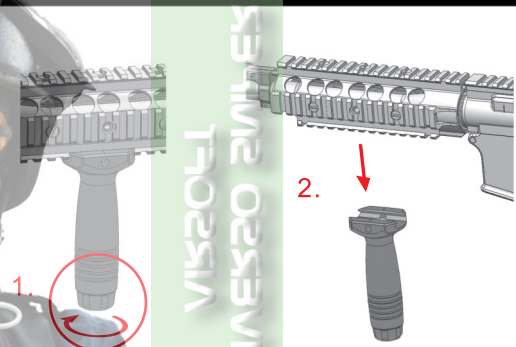

【6-5】：護木 Tactical handguard

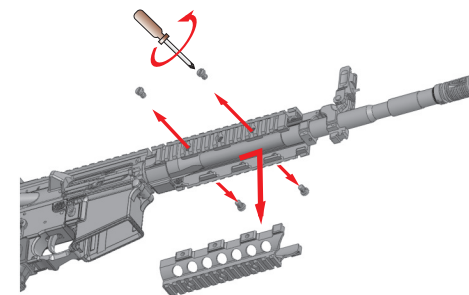

用螺絲起子卸下護木左右兩側的固定螺絲，即可將下護木卸下。

1. Turn the screw on the right side of hand guard counterclockwise to detach it.
2. Pull the hand guard forward to remove it.

警告·注意

- 拆卸護木時，請注意螺絲起子的旋轉方向，以免造成零件的損壞。

WARNING · CAUTION

- Be careful of the direction of screw driver when detaching the hand guard.

- 警語
- 簡介
- 各部名稱
- 選擇鈕
- 電池安裝
- 彈匣安裝
- 準星照門
- 動部說明**
- 射擊
- Hop-Up
- 故障診斷
- 分解圖表
- 售後服務
- 周邊產品

【6-6】：槍機拉柄與槍機助進器 Charging & Forward Assist Knob

- 警語
- 簡介
- 各部名稱
- 選擇鈕
- 電池安裝
- 彈匣安裝
- 準星照門
- 動部說明
- 射擊
- Hop-Up
- 故障診斷
- 分解圖表
- 售後服務
- 周邊產品

槍機拉柄可向後拉動。

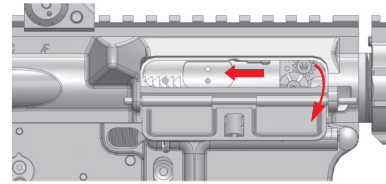
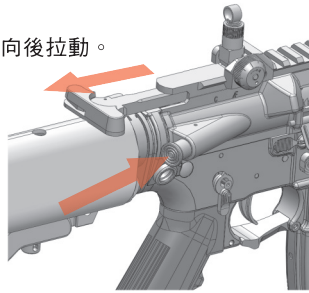

※拉動槍機拉柄可使槍機護蓋彈開。槍機固定在後可露出HOP-UP調整鈕

槍機助進器可押。

The Charging handle can be pulled and the bolt will be fastened.
The Forward Assist Knob can be pressed in.



警告·注意

- 操作槍機拉柄時，請小心誤被夾傷。

WARNING · CAUTION

- Be carefully and don't get hurt when pulling the charging handle.

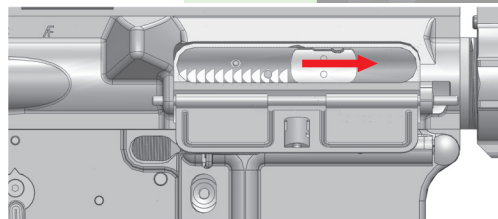

當HOP-UP調整完畢要將槍機歸位時只需押下槍身左側或右側的槍機釋放桿即可。

※Pulling the charging handle will expose the hop-up adjustment dial in the port cover. To release the bolt, just press the Bolt Catch.

7 射擊 Firing

※確認完全安全的情況下，方可進行射擊。
※Confirm safety sufficiently before beginning firing.

1. 將射擊選擇鈕設定在半自動或全自動位置。
Set the selector lever to Semi or Full Auto.

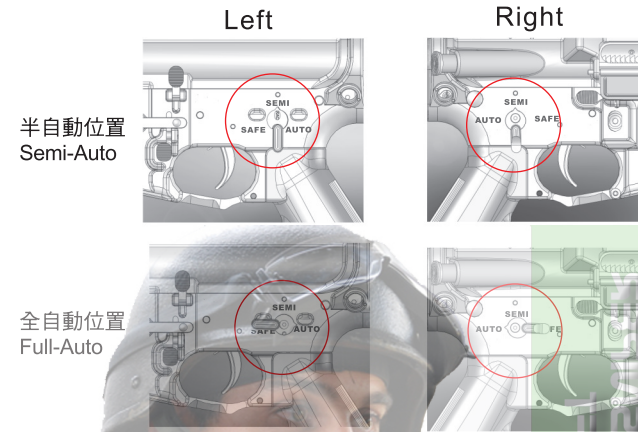

2. 扣扳機即可發射
Pull the trigger

注意

- 隨意扣動扳機非常危險。在確認射擊之前，請勿將手指放在扳機上。
- 裝上彈匣後，扣扳機第一發有可能是單發，此並非故障。

CAUTION

- Activating the trigger carelessly is extremely dangerous. Never put your finger onto the trigger unless you are ready to shoot a target.
- A blank firing may occur at triggering after setting the

警告·注意

- 在半自動射擊時，有時會發生扣扳機卻沒有反應的情形。此時切換到全自動模式，射擊5-6發後，再切回半自動模式，將會恢復正常運作。

WARNING · CAUTION

- There are possible cases that no firing occurs after pulling the trigger in the semi auto mode. In this case, do not pull the trigger furiously Fire 5 to 6 shots in the full auto mode and then return th the semi auto operation.

- 警語
- 簡介
- 各部名稱
- 選擇鈕
- 電池安裝
- 彈匣安裝
- 準星照門
- 動部說明
- 射擊
- Hop-Up
- 故障診斷
- 分解圖表
- 售後服務
- 周邊產品

- 警語
- 簡介
- 各部名稱
- 選擇鈕
- 電池安裝
- 彈匣安裝
- 準星照門
- 動部說明
- 射擊**
- Hop-Up
- 故障診斷
- 分解圖表
- 售後服務
- 周邊產品

警告 · 注意

- 請勿使用WD40、CRC556或其他礦物油。
- 射擊前請注意第二頁的警告事項。

WARNING · CAUTION

- Never use WD40, CRC556 or other mineral oil.
- Please read the warning on page 2 before shooting.

◎射擊終了時

- 拔下彈匣，往安全的方向全自動射擊2~3發，再切到半自動射擊1發以釋放彈簧，最後切回保險的位置。
- 彈匣雖未裝彈，但須注意槍膛內可能還會有殘彈。

◎馬達與電池的注意事項

- 射速減緩時，請將電池取下並予以充電。
- 馬達與電池在連續射擊500發之後，為避免過熱，請休息5~10分鐘。

◎卡彈時的處理

- 當卡彈發生時，將BB彈清理掉，並從彈匣進彈口噴入些許矽油，以保持含彈橡皮潤滑度。



◎After Operation

- Remove the magazine and dry fire the gun in the semi auto mode directing the muzzle to a safe direction. (Otherwise, the spring may be weakened.) Set the selector to the safe position.
- Bullets may remain in the chamber even if the magazine contains no bullets (or if the magazine is not connected).

◎Cautions on Motor and Battery

- Charge the battery if the firing cycle becomes slow.
- give the air gun a rest for 5 to 10 minutes after firing about 500 rounds, in order to ensure long service lives of the motor and battery.

◎When Bullets Are Clogged

- If bullets are clogged, remove them and apply a few drops of silicone oil into the chamber from the magazine entrances or spray silicone oil for 0.5 to 1 sec to obtain smooth continuous firing.

- 警語
- 簡介
- 各部名稱
- 選擇鈕
- 電池安裝
- 彈匣安裝
- 準星照門
- 動部說明
- 射擊**
- Hop-Up
- 故障診斷
- 分解圖表
- 售後服務
- 周邊產品

- ※拉開槍機座調整Hop-Up時，慎防夾手。
- ※Be careful not to catch your fingers in the dummy bolt.

所謂的Hop-Up是藉由橡皮給BB彈特定的方向迴轉，使之保持上揚的力道而能增加飛行距離。而可變Hop-Up系統則是可微調讓彈道平整的系統。

By giving rotation of the fixed direction to BB bullet, a lift is given and it flies horizontally toward a long distance target. Variable Hop-Up system can tune finely that a spin starts.

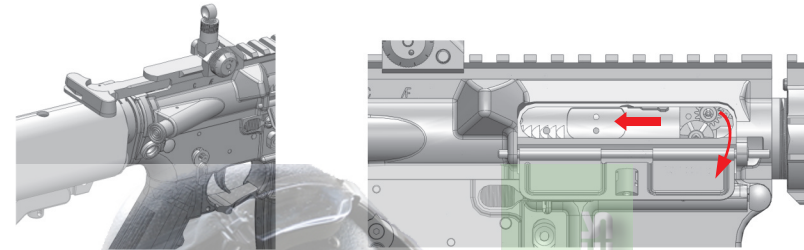

警告 · 注意

- Hop-Up調整過頭會造成卡彈。卡彈時持續擊發則會造成齒輪箱內部零件損毀。所以調整過頭時而造成卡彈時，請停止射擊，並將Hop-Up釋放，重新調整。

WARNING · CAUTION

- Moving the dial too much towards Hop causes bullets to clog. Adjust again after stopping shooting immediately, returning the dial to the Normal side and canceling hop, since a piston and gears will be damaged, if it continues shooting then.

- 拉開槍機時，可調整Hop-Up。
- 調整鈕往HOP的方向旋轉，則可讓彈道上揚。
- 調整過度或不足，會影響彈道的表現。

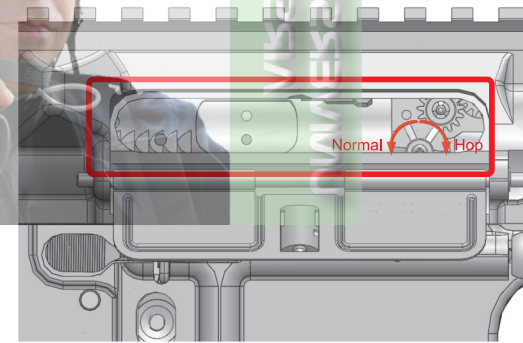

- Open bolt to adjust the Hop-Up system.
- Gradually turn the adjustment dial towards Hop to give hop up to bullets. (The best setting is where bullets fly horizontally.)
- Turning excessively adversely affects the trajectory. So, stop turning the dial when bullets fly horizontally.

- 警語
- 簡介
- 各部名稱
- 選擇鈕
- 電池安裝
- 彈匣安裝
- 準星照門
- 動部說明
- 射擊
- Hop-Up**
- 故障診斷
- 分解圖表
- 售後服務
- 周邊產品

如下圖所示，BB彈保持水平彈道為最佳位置，而飛行距離也會增加。
The best position is where the bullets fly horizontally and the longest flying distance is obtained.

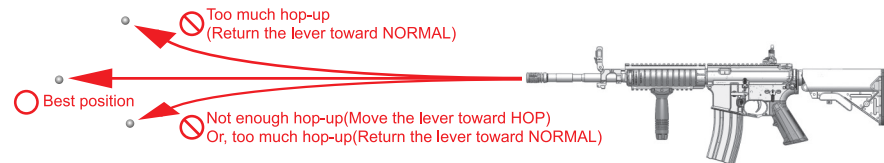

警告、注意

- Hop-Up系統會造成彈道彎曲。若槍倒下來射擊時，BB彈會大幅度往左右邊飛行而造成危險。所以請保持正常的射擊姿勢。
- 當射擊10000發以上，可噴少許矽油在Hop橡皮以進行保養。(約0.5到1秒即可)

WARNING · CAUTION

- Never hold the gun sideways as the BB bullets will curve right or left. This is due to the Hop-Up system.
- When about 10,000 rounds are fired, spray silicone oil to the chamber for 0.5 to 1 sec.

- 警語
- 簡介
- 各部名稱
- 選擇鈕
- 電池安裝
- 彈匣安裝
- 準星照門
- 動部說明
- 射擊
- Hop-Up**
- 故障診斷
- 分解圖表
- 售後服務
- 周邊產品

狀態	原因	處理方法
彈著上飄	Hop-Up調整過頭	調整桿往前調整。
BB彈飄不起來 (Hop-Up無作用)	Hop-Up調整過頭	調整桿往前調整。
	Hop橡皮有油污附著	清除油污。
	Hop橡皮破損	向經銷商或VFC購買零件來維修。
無法調整	調整桿或其他零件損壞	向經銷商或VFC購買零件來維修。
卡彈	Hop-Up調整過頭	調整桿向前調整，解除後再度調整。
	BB彈不良	請使用VFC優質BB彈
	Hop橡皮髒污	清除髒污

Symptom	Cause	Action
Bullets flying upwards	Too much hop setting.	Gradually return adjustment lever towards Normal.
Short flying distance of bullets (less hop-up effect)	Too much hop setting.	Gradually return adjustment lever towards Normal.
	Hop packing contaminated by oil or dirt.	Clean using the cleaning rod or consult your dealer or VFC for repair
Can not adjust	Worn or damaged hop packing.	Purchase the replacement part at your dealer or from VFC and replace it.
	Damaged adjustment lever or other parts	Purchase the replacement part at your dealer or from VFC and replace it.
Frequent bullet clogging	Too much hop setting.	After the adjustment lever is returned to anormal side, and the hop is released, it adjusts again.
	Improper or too large sized BB bullets.	Use the BB bullet supplied by VFC.
	Dirty hop packing	Clean using the cleaning rod or consult your dealer or VFC for repair

- 警語
- 簡介
- 各部名稱
- 選擇鈕
- 電池安裝
- 彈匣安裝
- 準星照門
- 動部說明
- 射擊
- Hop-Up
- 故障診斷**
- 分解圖表
- 售後服務
- 周邊產品

狀態	原因	處理方法
無法動作	選擇鈕位於關保險位置	開保險。
	電池未充電	電池充電。
	電池接頭未連接	電池接頭確實連接。
	電池接頭正負極接反	正確連接電極。
	馬達老化(約5~6萬發)或接點不良	更換馬達或修理接點。
馬達有轉動但BB彈無法擊發	彈匣內BB彈卡彈	清除彈匣內的卡彈
	槍膛內BB彈卡彈	清除槍膛內的卡彈
	齒輪損壞	向經銷商或VFC購買零件來維修
無法全自動射擊	電池電力不足	電池充電。
	彈匣給彈不良	清除彈匣內的卡彈。
無法半自動射擊	齒輪未正確歸位	切到全自動射擊5~6發後，再切成半自動射擊。

Symptom	Cause	Action
No operation at all	Selector lever is set to safety .	Set the selector lever to fire.
	Battery is no charged.	Charge the battery .
	Battery connector is disconnected.	Connect the connector .
	The + and - of battery connector is reversed.	Connect the connector correctly .
	Fuse is blown out.	Replace the fuse.
Although motor is revolving gun does't fire	Bullets are clogged inside the magazine	Insert the charging ord into the maga-zine and move it up and down a few times to remove clogged bullets.
	Bullets are clogged in the chamber .	Remove clogged bullets using the cleaning rod.
	Faulty gear	Purchase the replacement gear from your dealer or VFC and repair .
Malfunction of full auto operation (automatic firing)	Insufficient battery power	Charge the battery .
	Faulty bullet feed of magazine	Repair clogging of the magazine.
Malfunction of semi-auto operation	Poor electrical connection	Consult your dealer or VFC for overhaul maintenance or repair .

狀態	原因	處理方法
無法半自動射擊	電池電力不足	電池充電。
	接點不良	向經銷商或VFC購買零件來維修。
連射速度低落	電池電力不足	電池充電
BB彈射程變短	槍膛橡皮磨損	向經銷商或VFC購買零件來維修
	氣筒O環磨損	
	氣筒彈簧彈性疲乏	
動作聲音異常	BB彈不良，太小或太重	請使用VFC優質BB彈
	矽油耗盡	在槍膛添加數滴矽油
	空擊太過造成齒輪異常	向經銷商或VFC購買零件來維修。
齒輪損壞		
BB彈從槍口掉落	空擊太過造成齒輪異常	請使用VFC優質BB彈
	槍膛橡皮磨損	
	BB彈太小	

Symptom	Cause	Action	
Malfunction of semi-auto operation (single shot)	Insufficient battery power	Charge the battery .	
	Poor electrical connection	Consult your dealer or VFC for overhaul maintenance or repair	
Automatic firing cycles become slow	Insufficient battery power	Charge the battery .	
Shooting distance becomes shorter	Worn or damaged chamber packing	consult your dealer or VFC for overhaul maintenance or repair . Replace the chamber packing., piston packing(O-ring) and piston assembly .	
	Worn or damaged piston packing(O-ring)		
	Deteriorated piston spring		
	Faulty BB bullets (too small or heavy)		Use the genuine VFC BB bullets.
	Shortage of Silicone oil		Drop a few drops of silicone oil from under the chamber
Overly loud operating noise	Gear problems caused by excessive blank firing	consult your dealer or VFC for overhaul maintenance or repair . Replace the chamber packing., piston packing(O-ring) and piston assembly .	
	Worn of damaged gear		
Bullets falling out from barrel end	Gear problem caused by excessive blank firing	Use the genuine VFC BB bullets.	
	Worn or damaged chamber packing		

- 警語
- 簡介
- 各部名稱
- 選擇鈕
- 電池安裝
- 彈匣安裝
- 準星照門
- 動部說明
- 射擊
- Hop-Up
- 故障診斷**
- 分解圖表
- 售後服務
- 周邊產品

SR-15/16 E3 IWC parts list

- | | |
|-----------------------------------|--------------------------------|
| SR 01 -Flash Hider | SR 26 -Left Magazine Catch Set |
| SR 02 -Front Sight Set | SR 27 -Lock Pin |
| SR 03 -SR15 Front Barrel Set | SR 28 -Left Selector Lever |
| SR 04 -SR15 Dummy Bolt Plate | SR 29 -Selector Lever Flap |
| SR 05 -SR15 Rear Barrel Set | SR 30 -Pistol Grip |
| SR 06 -SR16Out Barrel Set | SR 31 -Sr15 Inner Barrel |
| SR 07 -SR16 Gas Tube | (SR31A-SR16 Inner Barrel) |
| (SR 07A-SR15 Gas Tub) | SR 32 -Hop-Up Charmber |
| SR 08 -SR16Tactical Handguard | SR 33 -Hop-Up Set |
| (SR 08A-SR15Tactical Handguard) | SR 34 -Gear Box Set |
| SR 09 -Rail Cover Panel | SR 35 -Motor Set |
| SR 10 -Forward Pistol Grip | SR 36 -Selector Lever Gare Set |
| SR 11 -Upper Reciver Set | SR 37 -Magazine |
| SR 12 -Gas Block | SR 38 -Receiverend-plate |
| SR 13 -Port Cover Set | SR 39 -Stock Tube Set |
| SR 14 -Assist Knob Set | SR 40 -Crane SOPMOD Stock Set |
| SR 15 -Charging Handle | |
| SR 16 -Knight 600m Rear Sight | |
| SR 17 -Knight 300m Rear Sight | |
| SR 18 -SR-15/16 Lower Reciver Set | |
| SR 19 -Front Frame Lock Pin | |
| SR 20 -Right Bolt Catch Set | |
| SR 21 -Right Selector Lever | |
| SR 22 -Rear Frame Lock Pin | |
| SR 23 -Right Magazine Catch Set | |
| SR 24 -Trigger Guard | |
| SR 25 -Left Bolt Catch Set | |

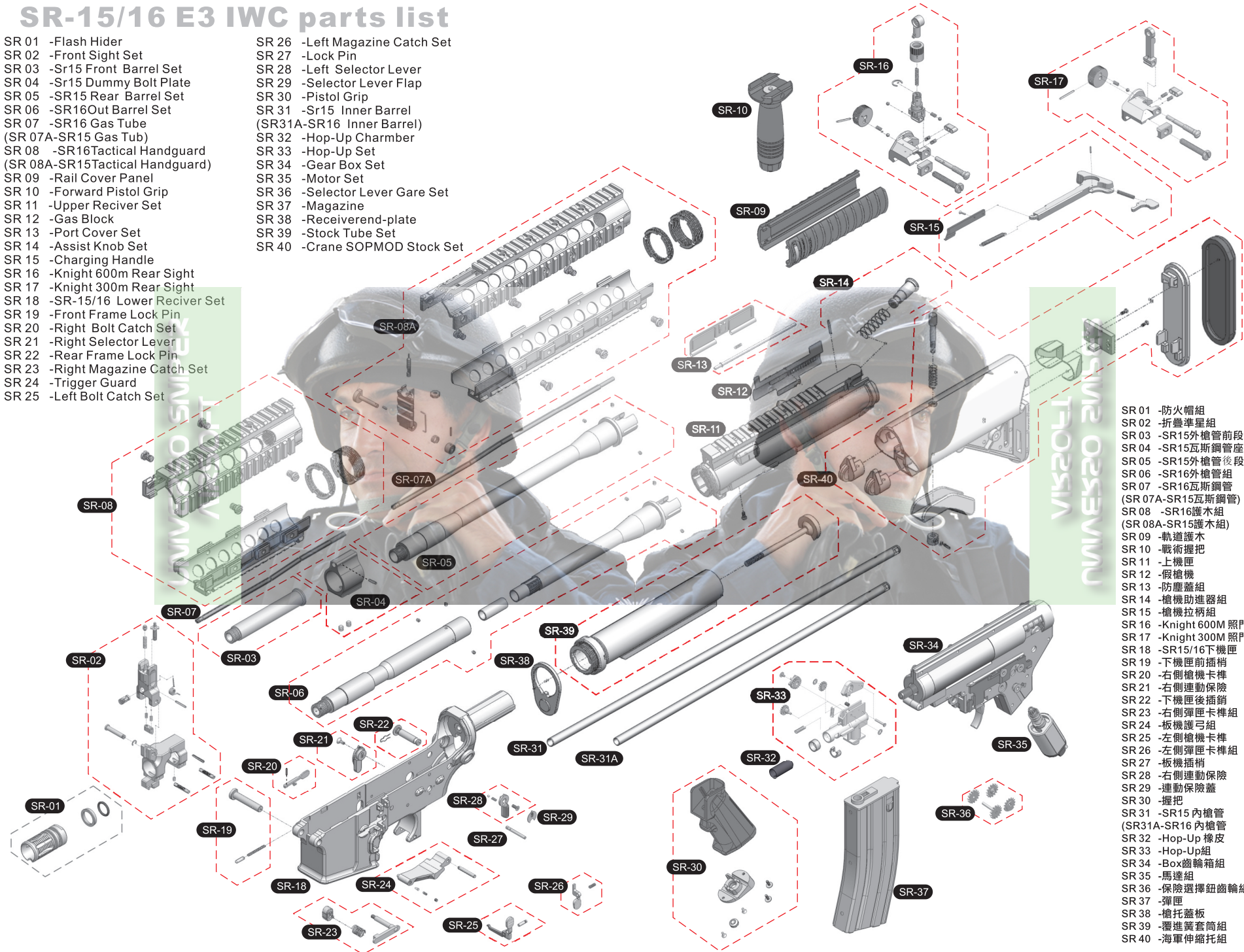

- | |
|------------------------|
| SR 01 -防火帽組 |
| SR 02 -折疊準星組 |
| SR 03 -SR15外槍管前段 |
| SR 04 -SR15瓦斯鋼管座 |
| SR 05 -SR15外槍管後段 |
| SR 06 -SR16外槍管組 |
| SR 07 -SR16瓦斯鋼管 |
| (SR 07A-SR15瓦斯鋼管) |
| SR 08 -SR16護木組 |
| (SR 08A-SR15護木組) |
| SR 09 -軌道護木 |
| SR 10 -戰術握把 |
| SR 11 -上機匣 |
| SR 12 -假槍機 |
| SR 13 -防塵蓋組 |
| SR 14 -槍機助進器組 |
| SR 15 -槍機拉柄組 |
| SR 16 -Knight 600M 照門組 |
| SR 17 -Knight 300M 照門組 |
| SR 18 -SR15/16下機匣 |
| SR 19 -下機匣前插銷 |
| SR 20 -右側槍機卡榫 |
| SR 21 -右側連動保險 |
| SR 22 -下機匣後插銷 |
| SR 23 -右側彈匣卡榫組 |
| SR 24 -板機護弓組 |
| SR 25 -左側槍機卡榫 |
| SR 26 -左側彈匣卡榫組 |
| SR 27 -板機插銷 |
| SR 28 -右側連動保險 |
| SR 29 -連動保險蓋 |
| SR 30 -握把 |
| SR 31 -SR15內槍管 |
| (SR31A-SR16內槍管 |
| SR 32 -Hop-Up 橡皮 |
| SR 33 -Hop-Up組 |
| SR 34 -Box齒輪箱組 |
| SR 35 -馬達組 |
| SR 36 -保險選擇鈕齒輪組 |
| SR 37 -彈匣 |
| SR 38 -槍托蓋板 |
| SR 39 -擲進簧套筒組 |
| SR 40 -海軍伸縮托組 |

- 警語
- 簡介
- 各部名稱
- 選擇鈕
- 電池安裝
- 彈匣安裝
- 準星照門
- 動部說明
- 射擊
- Hop-Up
- 故障診斷
- 分解圖表
- 售後服務
- 周邊產品

- 警語
- 簡介
- 各部名稱
- 選擇鈕
- 電池安裝
- 彈匣安裝
- 準星照門
- 動部說明
- 射擊
- Hop-Up
- 故障診斷
- 分解圖表
- 售後服務
- 周邊產品

- 警語
- 簡介
- 各部名稱
- 選擇鈕
- 電池安裝
- 彈匣安裝
- 準星照門
- 動部說明
- 射擊
- Hop-Up
- 故障診斷
- 分解圖表
- 售後服務
- 周邊產品

【有限保固】

- 本產品自購買日起，本公司提供一個月或30,000發的有限保固(以先達到條件者為準)。
- 保固範圍：齒輪箱內部零件。(不包含馬達)
- 本產品經過嚴密之檢查與試驗，在保證期間內產品因正常使用而發生故障，經本公司認證之技術人員確認為製造或材料上之瑕疵時，本公司將負責免費維修。
- 以下情形，本公司將不負責保證責任：
 - 未登錄槍之序列號碼者。
 - 非本公司認證之技術人員修裝而導致之故障。
 - 經查驗非本公司經銷商所銷售之槍型，無法提供註冊卡及經銷商蓋印章者
 - 因火災或其他天災、地變等因素所導致之故障。

【零件維修】

- 本產品在正確及適當的使用方法下操作，約30000發以後，Hop-Up橡皮等消耗性零件仍有交換的必要。像是超過保固期限的耗材，或因操作疏失所發生的故障以及保養的場合，可透過經銷商或直接向本公司訂購備用零件。
- 有序列號碼的零件本公司無法提供相同序列號碼的零件。
- 訂購的方法請參考VFC網站<http://www.gb-tech.com.tw>
- 下列行為本公司將不提供保固，亦不提供零件服務：
 - 任何外觀上的改造或變更原來內部構造所發生之故障。
 - 未依說明書所示之正確使用方法，不論是故意或過失因素所發生之故障。

Limited Warranty

- Vega Force Company (VFC) warrants the AK-74 AEG against defects in materials and workmanship for a period of one month or 30,000 rounds BB bullets shoot from the date of original purchase ("Warranty Period").
- Warranty coverage: Internal parts of gearbox. The cosmetic parts and electric motor are not cover by warranty.
- We inspect and test each product before delivery to customer. In warranty period, the repair service will be provide by ours certify technician after determine the problem or damage defects in materials and workmanship.
- This warranty does not apply: (a) to damage caused by accident, abuse, misuse, misapplication, or non-VFC products; (b) to a product or a part that has been modified without the written permission of VFC or his agent; or (c) to no register your series number with VFC with in 7 days of purchase date; (d) to if any VFC serial number has been removed or defaced; or (e) to disassembly or modify by unauthorized person; (f) to the products not purchase from VFC authorize dealer with valid warranty card.

Maintenance & Replacement Parts

- The Hop-Up bucking and few parts will be recommended to change each 30,000 rounds BB bullets shoot.
- We may unable to provide match series number on replacement parts.
- If you unable to obtain locally, Please check <http://www.gb-tech.com.tw> for more information.

- 警語
- 簡介
- 各部名稱
- 選擇鈕
- 電池安裝
- 彈匣安裝
- 準星照門
- 動部說明
- 射擊
- Hop-Up
- 故障診斷
- 分解圖表
- 售後服務
- 周邊產品

相關配件 / Accessories

Knight type 快拆槍背帶環 knight type Push-Button Swivel	AR-15 / M4 大容量彈匣 AR-15 / M4 High Capacity Magazine	Knight type M4 / M16 QDSS-NT4 消音器與快拆式防火帽組 Knight type M4 / M16 QDSS-NT4 Suppressor & QD Flash Hider	AR15 / M4 伸縮托組 Ar15 / M4 Stock Set

次期產品 / Next Products

■ KAC PDW

■ EGLM

■ AKMS

■ AKM

