

STONER SR-16 E3 MOD2 6mm GAS BLOWBACK RIFLE



VegaForce Company
<https://www.vegaforce.com>



OPERATORS MANUAL

MANUFACTURED BY  FOR **ZSHOT**
MANUFACTURED UNDER LICENSE FROM KNIGHT'S ARMAMENT Co.

8F., No.609, Sec. 1, Wanshou Rd., Guishan Dist.,
Taoyuan City 333, Taiwan (R.O.C.)
Phone: +886-2-8200-6630
Fax: +886-2-8200-6631
e-Mail: service@vegaforce.com.tw

WARNING

- Always wear eye protective gear.
- Never shoot the gun at places where people and cars pass cross.
- Never aim or shoot a person or animal as a target.
- Never look into the gun muzzle.
- Always direct the muzzle towards a safe direction.
- Avoid pulling the trigger carelessly.
- Please put away from your fingers from the trigger, except when you are ready to shoot a target.
- Always put the gun in a case or bag when you are carrying it.
- Keep out of reach of children.

注意事項/警告

- 始終佩戴護目鏡。
- 切勿在有人和汽車通過的地方開槍。
- 切勿將人或動物作為目標瞄准或射擊。
- 切勿直視槍口。
- 始終將槍口指向安全的方向。
- 避免不小心拉動扳機。
- 除準備射擊目標外，請不要將手指放在扳機上。
- 攜帶槍支時，請務必將其放在箱子或袋子中。
- 請將本品放在兒童不能接觸的地方。

SPECIFICATIONS / 產品諸元



Overall Length / 全長: 740mm / 820mm
 Weight / 重量: 2080g
 Magazine / 填彈數: 30Rds
 Barrel Length / 內管長: 12" / 320mm
 Muzzle Velocity / 槍口初速: 400 + FPS
 Caliber / 彈種: 6mm BB



Overall Length / 全長: 800mm / 880mm
 Weight / 重量: 2380g
 Magazine / 填彈數: 30Rds
 Barrel Length / 內管長: 15" / 380mm
 Muzzle Velocity / 槍口初速: 400 + FPS
 Caliber / 彈種: 6mm BB

COMPONENT NAME / 組件名稱

Right Side

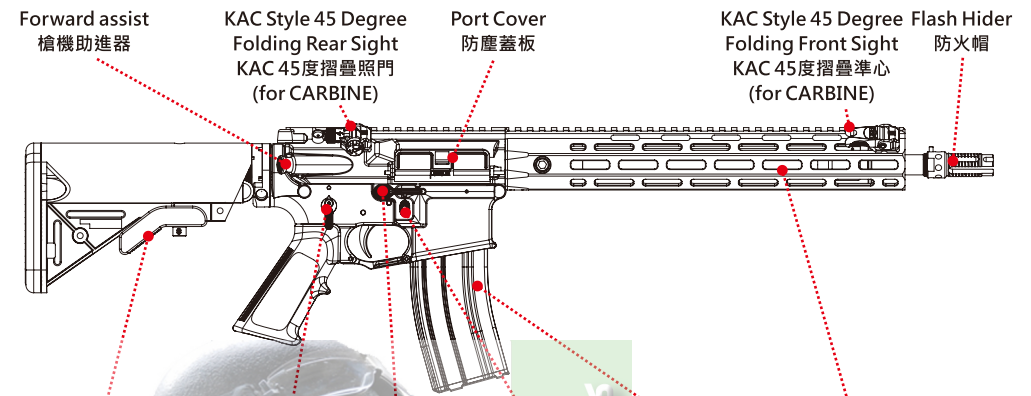

Left Side

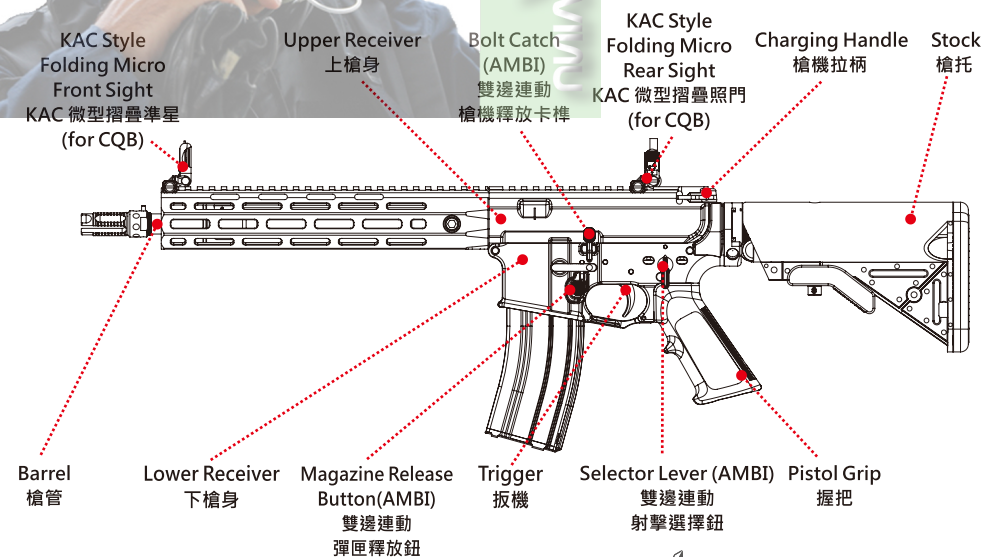

STOCK / 槍托

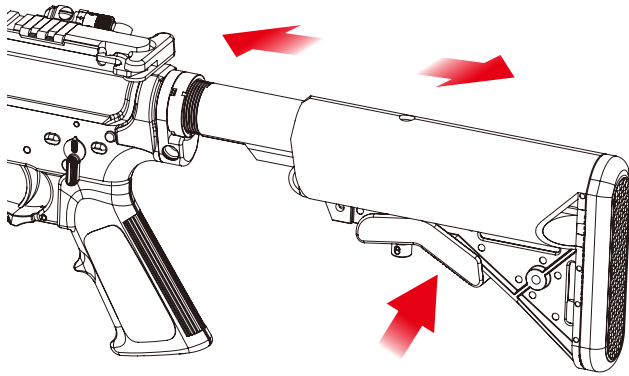

- Pulling up the stock release lever to extend stock in multiple positions.
按壓槍托卡榫可調整槍托位置

Flip-Up Sights / 摺疊準星照門

Flip-Up Front Sight

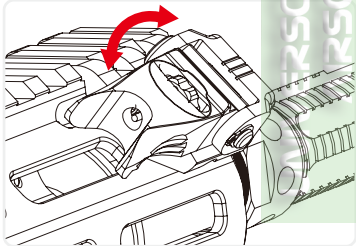

Flip-Up Rear Sight

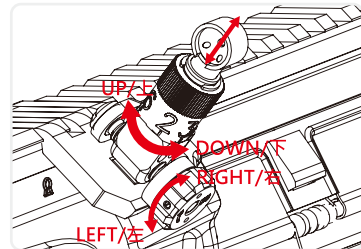
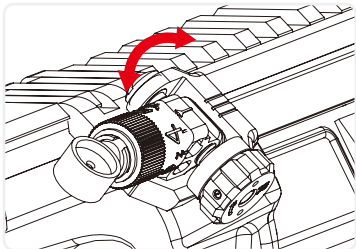

SELECTOR LEVER / 射擊選擇鈕

※ CAUTION: DO NOT TURN THE SAFETY LEVER WHILE PULLING THE TRIGGER.
請勿在扣壓扳機時，撥動射擊選擇鈕。

Right Side

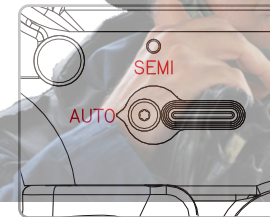
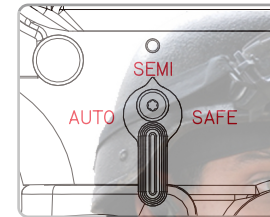
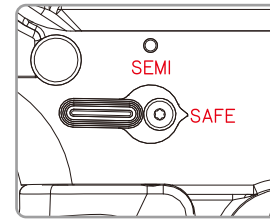

Left Side

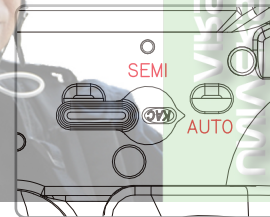
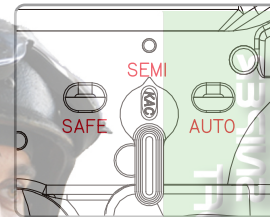
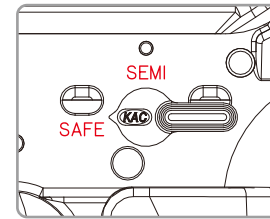

SAFE

- SAFE indicates the trigger cannot be pulled.
保險標示。當射擊選擇鈕轉至保險位置，則無法扣動扳機。

SEMI

- SEMI indicates one shot per trigger pull.
半自動標示。當射擊選擇鈕轉至半自動位置，扣壓一次扳機，發射一發子彈。

AUTO

- AUTO indicates that the gun will continue firing bb's until the trigger is released or the magazine runs out of bb's.
全自動標示。當射擊選擇鈕轉至全自動位置，扣壓扳機時，會持續發射子彈，直到釋放扳機或彈匣內BB彈耗盡。

- When the safety is rotated to SAFE position, the rifle (hammer) is fully cocked, but the firing sear is blocked from movement providing protection from accidental discharge under normal usage when the safety is properly engaged and serviceable.
當射擊選擇鈕旋至保險位置時，擊錘雖已在待發位置，但擊錘阻鐵是不可作動的。在正常情況下提供槍支安全的保護。
- To rotate the safety to the SAFE position, pull the charging handle fully to rear visually checking that the chamber is clear by observing through the ejection port as the bolt is retracted by the charging handle. The safety may be rotated to the SAFE position any time the bolt is held fully to the rear or when the bolt is forward and the hammer is cocked.
將射擊選擇鈕轉至保險位置，並將槍機拉柄完全拉至最後，從拋殼口檢視槍膛無殘彈後再將拉柄送回。當擊錘被固定在後時，任何時候都可以將射擊選擇鈕轉至保險位置。

※ WARNING: NEVER PUT YOUR FINGER ON THE TRIGGER UNTIL YOU'RE READY TO FIRE.
除準備射擊目標外，請不要將手指放在扳機上。

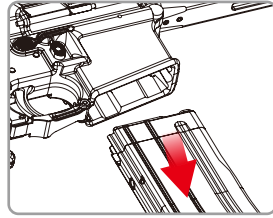
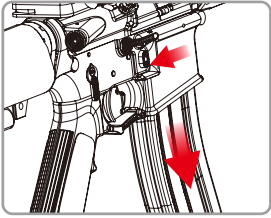

- **Remove the Magazine / 卸下彈匣**
Press Magazine catch button and remove the Magazine.
按下彈匣釋放鈕將彈匣卸下。

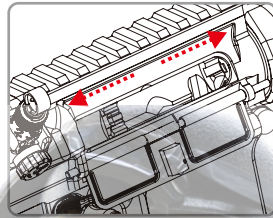
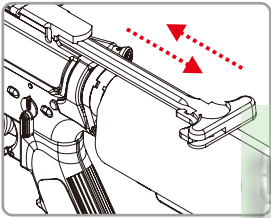

- **Cocking the Bolt / 槍機操作**
Lock Bolt open, Pull Charging handle rearward to check that there is no BBs in the chamber, Return Charging handle to forward. If there is, please remove the BBs from the chamber. Check the Bolt and Charging handle to ensure free movement in the receiver.
將槍機拉柄固定在後，檢查槍膛內是否有殘餘BB彈，如果有請將BB彈取出，並將槍機拉柄復位。檢查槍機與槍機拉柄作動是否正常。

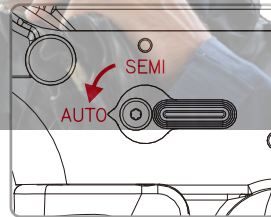
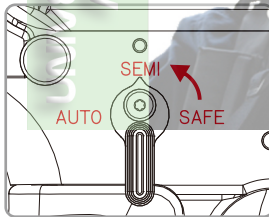
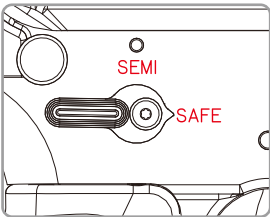

- **Check the Selector Lever / 檢查射擊選擇鈕**
Perform safety function check to ensure that safety selector lever works properly.
檢查並確認射擊選擇鈕是否正常作動。

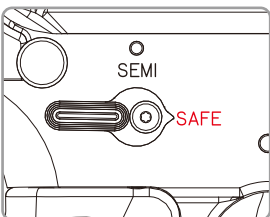

- **Safety Setting / 保險設置**
Place safety selector lever on safe.
將射擊選擇鈕轉至保險位置。

NOTE:
If The Rifle Is Not Cocked, The Selector Lever Can Not Be Pointed Toward The Safety Setting.
若步槍尚未上膛，則射擊選擇鈕不能轉至保險位置。

WARNING:
Always Point The Muzzle In a Safe Direction.
始終將槍口指向安全方向。

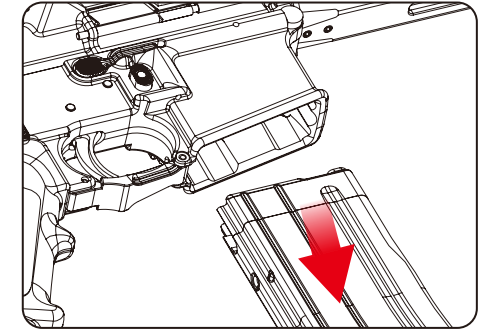
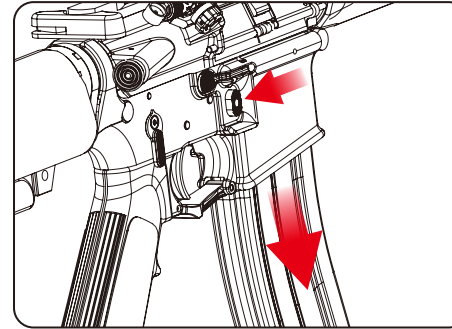

- **Press Magazine catch button and remove the Magazine.**
按下彈匣釋放鈕將彈匣卸下。

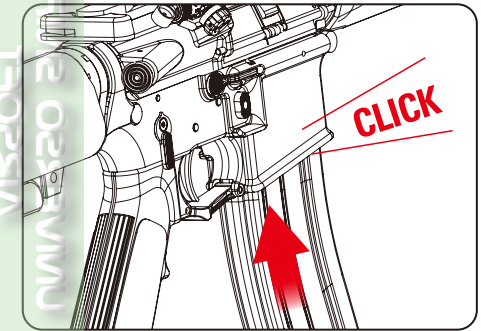
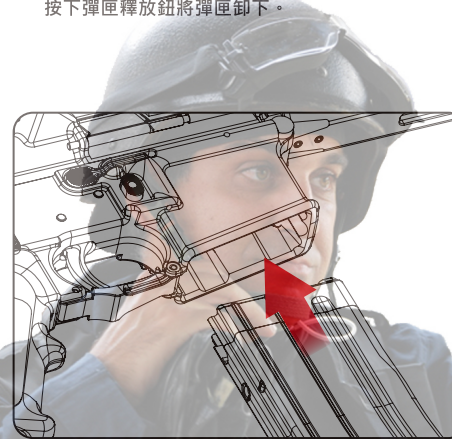

- **Push magazine up in to magazine well. Make sure to set the magazine upwards and connect it firmly until a CLICK SOUND is heard.**
將彈匣向上推入彈匣井內，確保彈匣插入方向正確。向上插入直到聽到喀噠聲為止。

※ **CAUTION: DO NOT PULL THE TRIGGER WHILE LOADING THE MAGAZINE.**
安裝彈匣時請勿扣擊扳機。

1. BB Loader / BB彈填彈器

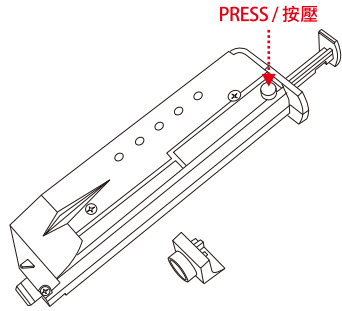

2. Insert the BBs to Loader / 將BB彈裝入填彈器

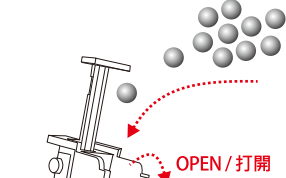

3. Load BBs / 裝填BB彈

Insert the BBs into the Magazine.
The maximum capacity is 30 rounds.
將BB彈裝入彈匣內，最大裝彈數為30發。

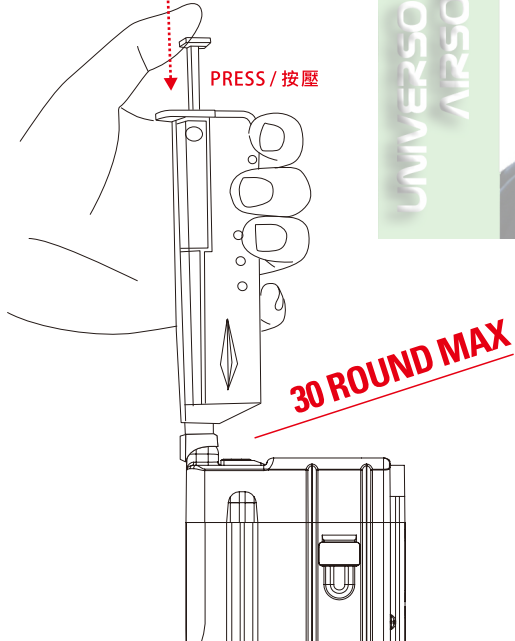

! Always use the quality BBs for this airsoft gun. We will not be held responsible for any damage and accidents arising from using of bad quality BBs.

請使用原廠或品質良好的BB彈。若因使用劣質的BB彈造成玩具槍毀損，本公司不負相關保固之責任。

-  **Diameter Larger Than 6mm**
直徑大於6mm
-  **No True Round Bbs**
並非真圓
-  **Both Halves Not Aligned**
有模線痕跡
-  **With Flash**
有裂紋或破損
-  **Used Or Soiled**
已使用過或表面髒污

CAUTION: Do Not Force To Over Load.
注意：請勿裝填過量BB彈。

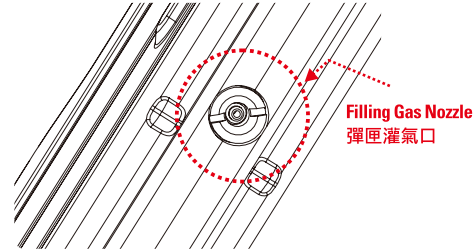

1. Check the Nozzle / 確認彈匣灌氣口

Push the gas canister nozzle into the Filling gas nozzle. Make sure the canister is in vertical position when charging.

將瓦斯罐接嘴對準並接上彈匣灌氣口，用力壓下開始填充。並確保彈匣灌氣口與瓦斯罐接嘴的垂直。

V GAS
CORE POWER GREEN GAS

PRESS 5-8 SEC
填充5-8秒



2. Filling the Gas / 填充瓦斯

For the better performance of the GBB rifle. Do not shoot the rifle right after charging the gas.
為了獲得最佳的效能，填充瓦斯完畢請勿立即開槍射擊。

CAUTION: Do not inject pressurized gas that above 12 Kg/cm to avoid damage to the product.

注意：請勿使用壓力高於12kg/cm的瓦斯，以免造成槍枝毀損。

3. Release the Gas / 釋放瓦斯

Please discharge the magazine by press the value gently, for releasing residual gas.

請按下氣閥釋放鈕，釋放彈匣內殘餘的瓦斯。

CAUTION / WARNING

1. Keep hands and face at a safe distance from the escaping gas.
 2. Escaping gas may cause icing.
 3. Gas may explode if exposed to temperatures exceeding 50 °C.
 4. Do not smoke, keep away from naked flames.
The gas is highly inflammable.
 5. Check canister for any cracks or leaks before using.
 6. Do not boil canister.
 7. Keep canister away from direct sunlight.
 8. Do not leave canisters inside the vehicle.
1. 注意洩漏的瓦斯，避免肢體和臉部過於靠近。
 2. 洩漏的瓦斯可能會導致結霜。
 3. 如果暴露在超過攝氏50度的溫度下，可能導致瓦斯氣體過度膨脹或爆炸。
 4. 瓦斯屬於高度易燃物質，填充瓦斯時，請勿吸菸並遠離火源及高溫處。
 5. 使用前，請檢查瓦斯罐是否有裂紋或洩漏。
 6. 請勿加熱瓦斯罐。
 7. 瓦斯罐請避免陽光直射並存放於室內陰涼處。
 8. 請勿將瓦斯罐留在車內。

READY TO FIRE / 射擊準備

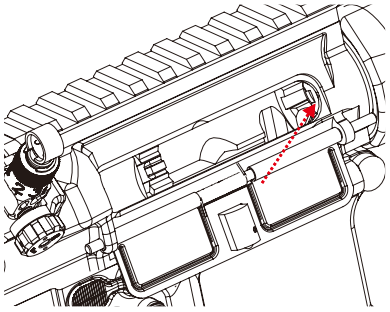

1. Check the Chamber / 檢查槍膛

Open bolt and check firing chamber.
Make sure it is clear.

槍機後定，確認槍膛內暢通無異物。

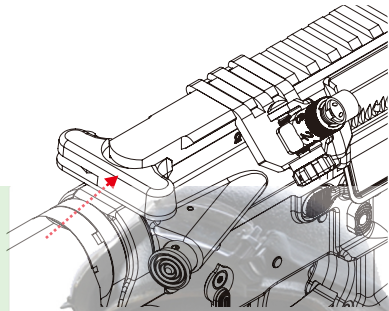
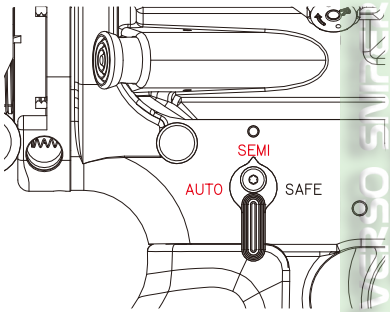

2. Return the Charging Handle / 槍機拉柄復位

forward the charging handle to locked position.
推動槍機拉柄復位。

WARNING: Always Point The Muzzle In a Safe Direction.

警告：始終將槍口指向安全方向。

3. Firing Mode Select / 射擊模式選擇

- To rotate the safety selector lever on Fire Position.

- Pull the Trigger to fire.

- 將射擊選擇鈕轉至射擊位置。

- 扣動扳機射擊。

RELEASE BOLT / 槍機釋放

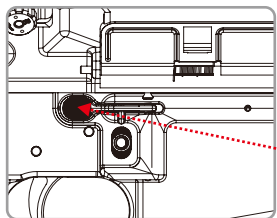

PRESS
按壓

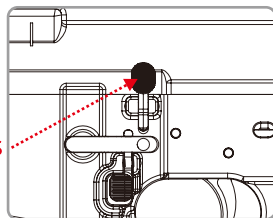

Press the Button release Bolt to Chamber.

按壓槍機釋放鈕釋放槍機，使槍機復位。

VARIABLE HOP-UP SYSTEM / HOP-UP調整系統

This HOP-UP system is adjusted by 3mm hex wrench.

使用3mm六角扳手調整HOP-UP系統。

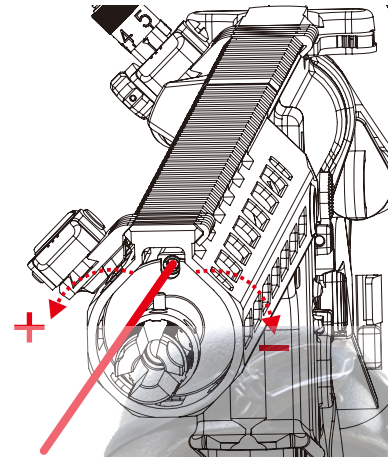

GuideHOP

Save time, Convenient and Fast

The SR-16 E3 Series GBBR uses our new patented "GuideHOP" HOP-UP adjust system.

There is no need to disassemble the handguard or upper and lower receiver when you need adjust your HOP-UP. All you only need a 3mm hex wrench to adjust HOP-UP at gas block.

You can adjust HOP-UP in anytime, anywhere, quickly and easily, without any disassembly.

省時、方便、快速

SR-16 E3 系列瓦斯槍採用VFC最新專利的"GuideHOP" 彈道調整設計。

無需分解槍支，只需要使用3mm六角扳手即可在瓦斯鋼管座處進行彈道調整。

您可以隨時隨地、快速方便的調整，無需任何拆解，大大減少因拆解所造成的不便與毀損。

ADJUST HOP EFFECT / 調整HOP效果

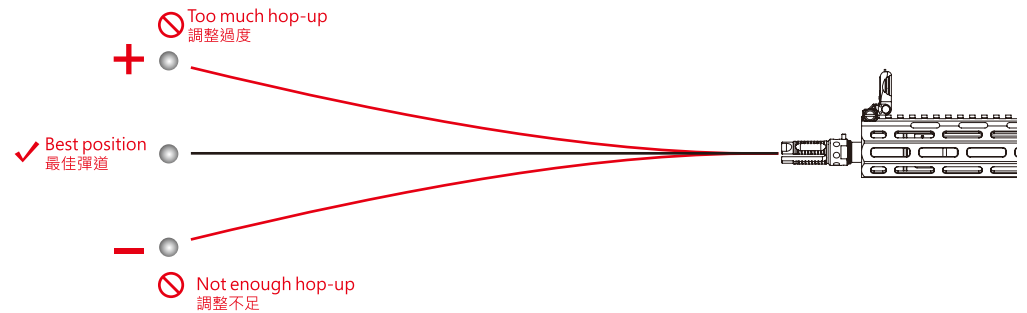

NOTE:

Never hold the gun sideways as BB bullets will curve right or left.

this is due to the HOP UP system. The Best setting is, where bullets fly horizontally.

請勿翻轉或傾斜射擊你的槍，這會造成射出的彈道偏左或偏右。

對於HOP UP系統設計，水平持握射擊是最好的射擊方式。

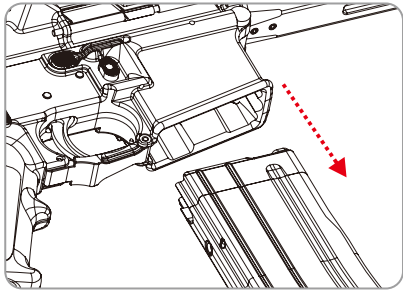

1. Remove the Magazine / 卸除彈匣
Press Magazine catch button and remove the Magazine.
按下彈匣釋放鈕將彈匣卸下。

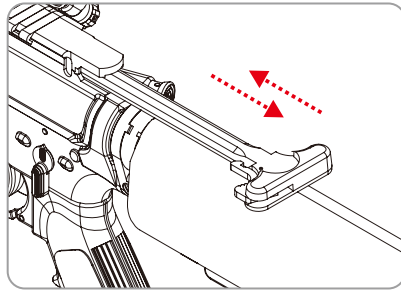

2. Cocking the Hammer / 擊錘復位
Pull the Charging handle rearward, Cocked the Hammer, Return Charging handle to forward.
拉動槍機拉柄將擊錘復位。

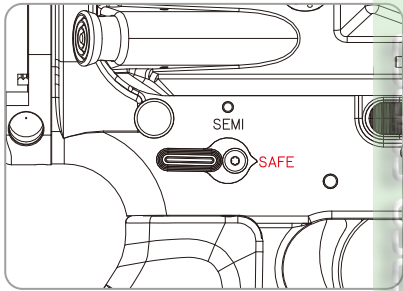

3. Safety setting / 保險設置
Place safety selector lever on safe.
將射擊選擇鈕轉至保險位置。

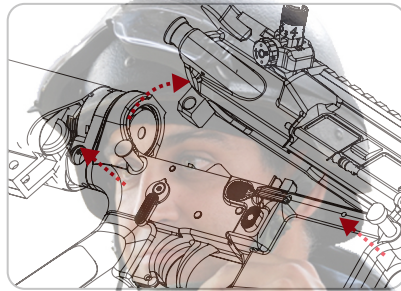

4. Pull Up the Take Down Pin and Pivot Pin / 拉出上下槍身結合插梢
— Push in Take down pin as far as it will go. Pivot Upper receiver from lower receiver.
— Push in pivot pin. Separate Upper and lower receiver.
- 推出槍身後結合插梢，將上槍身從下槍身打開。
- 推出槍身前結合插梢，完整分開上下槍身。

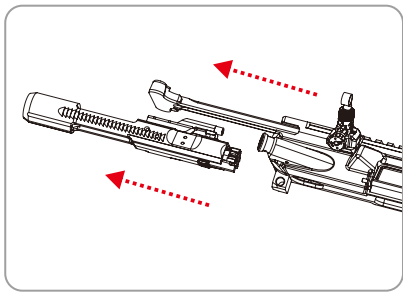

5. Remove the Bolt Assembly / 卸除槍機組件
Pull back the charging handle. Take down the bolt carrier and bolt.
向後拉出槍機拉柄，並取出槍機。

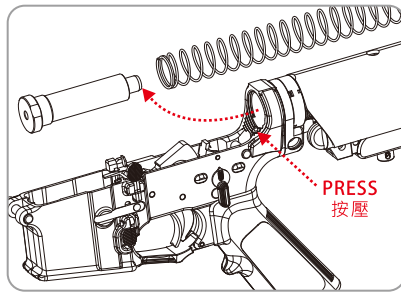

5. Remove the Buffer Assembly / 卸除緩衝機組件
Press the Buffer stop pin, Pull out the Action Spring and Buffer.
按下緩衝機固定梢，拉出覆進簧與緩衝機。

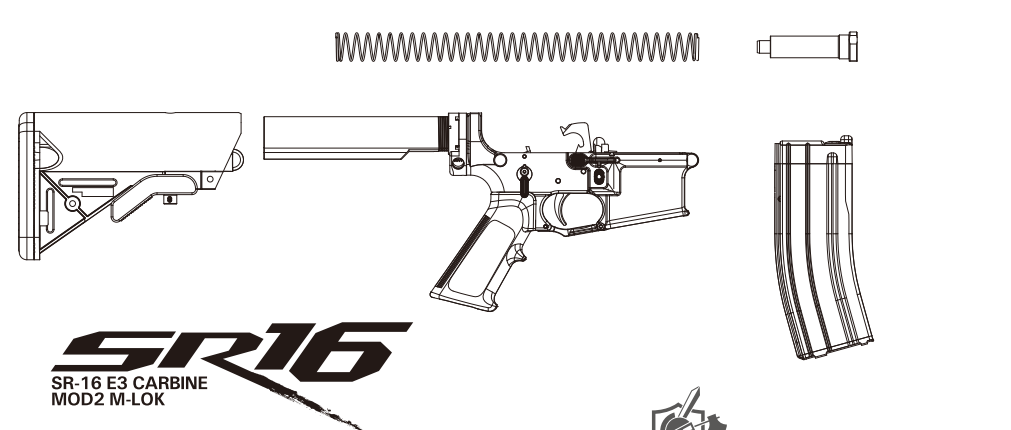
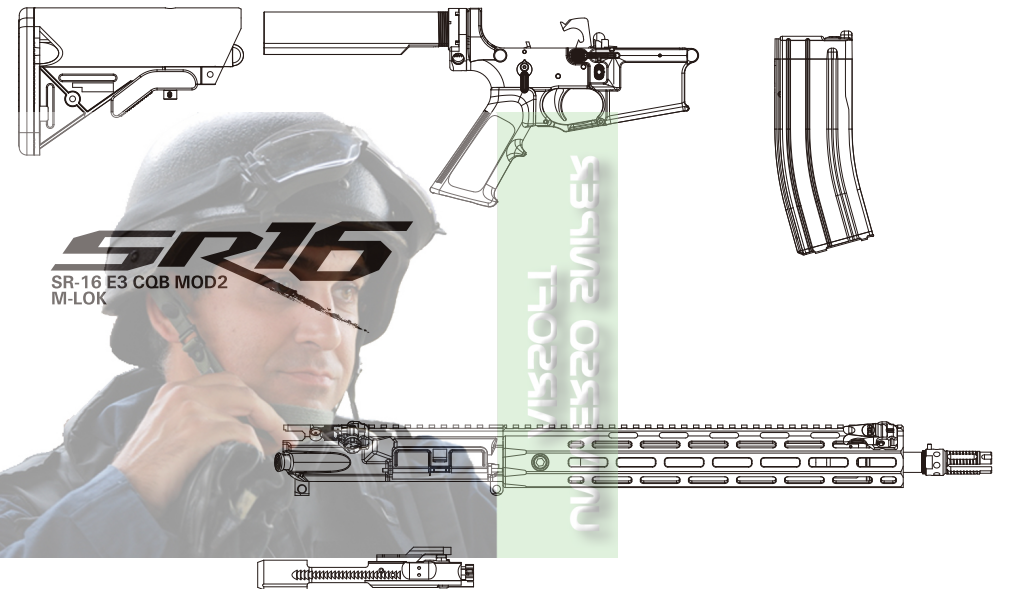
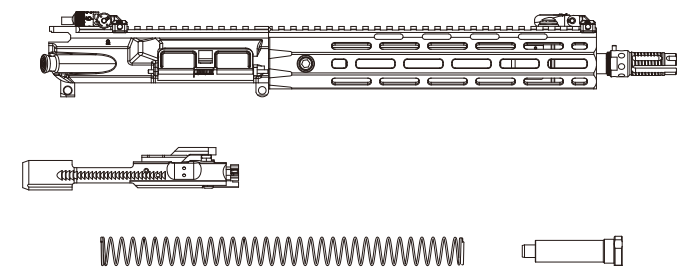

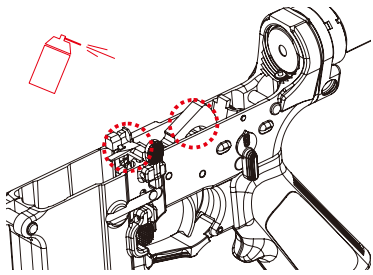

a. Lower Receiver / 下槍身
Lightly lubricate all moving parts inside the lower receiver.
些微潤滑下槍身內的可動部件。

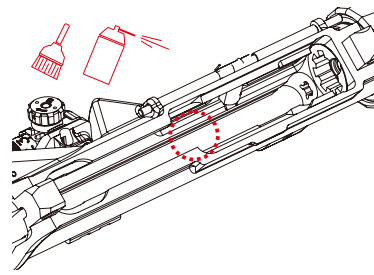

b. Upper Receiver / 上槍身
Clean all areas and out of fouling, Metal debris and dirt.
清潔所有區域並清除污垢與金屬碎屑。

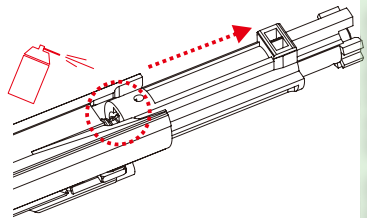

c. Bolt Assembly / 槍機組件
Use silicone oil lightly lubricate all contact area.
使用矽油將所有可接觸區域做些微潤滑。

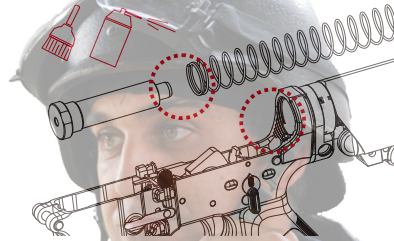

d. Buffer Assembly / 緩衝機組件
Clean all areas and use silicone oil lightly lubricate all contact area.
清潔並使用矽油將所有可接觸區域做些微潤滑。

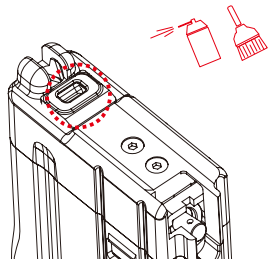

e. Magazine / 彈匣
Clean all areas and out of fouling, Metal debris and dirt.
清潔所有區域並清除污垢與金屬碎屑。

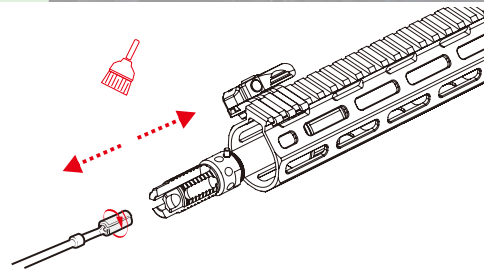

f. Inner Barrel / 槍支內管
Use patch holder to clean the inner barrel.
使用通槍條清潔槍支內管。

CAUTION: Use silicone oil the lubrication only.
Do not use WD-40 as lubrication.
僅使用矽油潤滑。請勿使用WD-40進行潤滑。

Symptom / 徵狀	Cause / 原因	Action / 解決方式
No operation at all. 操作沒有反應	<ol style="list-style-type: none"> No Gas in Magazine. 彈匣內沒有瓦斯。 Selector lever on safe. 射擊選擇鈕在保險位置。 Not loaded. 未上膛。 The Magazine is in low temperature. 彈匣溫度過低。 The pressure inside the Magazine is too high. 彈匣內壓力過高。 	<ol style="list-style-type: none"> Unload the Magazine and filling the Gas. 卸下彈匣並填充瓦斯。 Turn the selector lever on semi/full auto sites. 將射擊選擇鈕轉至半自動/全自動射擊模式。 Pull the Charging handle, loading the rifle. 拉動槍機拉柄，使步槍上膛。 After running fire, the Magazine will be in low temperature. Please, unload the Magazine until the Magazine temperature rise to normal. 射擊後，彈匣將處於低溫狀態。請卸下彈匣，靜待彈匣恢復常溫。 Do not use Gas which pressure is surpassed 12 Kg/cm . 請勿使用壓力高於12 Kg/cm 的瓦斯。
Magazine leak. 彈匣漏氣	<ol style="list-style-type: none"> O ring aged. O環老化。 O ring broken. O環斷裂。 Charging valve broken. 彈匣灌氣口損壞。 	<ol style="list-style-type: none"> 1.2.3. Purchase the replacement part at your dealer or from VFC. 向經銷商或VFC購買替換零件。
The recoil force decreases. 後座力變小	<ol style="list-style-type: none"> The Magazine is in low temperature. 彈匣溫度過低。 The gas pressure is insufficient. 瓦斯氣體壓力不足。 Lubrication insufficiency. 潤滑不足。 Bolt O ring broken. 槍機O環破損。 	<ol style="list-style-type: none"> 1. After running fire, the Magazine will be in low temperature. Please, unload the Magazine until the Magazine temperature rise to normal. 射擊後，彈匣將處於低溫狀態。請卸下彈匣，靜待彈匣恢復常溫。 2. Unload the Magazine and refill the gas. 卸下彈匣並重新填充瓦斯。 3. The moving part needs lubrication. 可動部件需要潤滑保養。 4. Purchase the replacement part at your dealer or from VFC. 向經銷商或VFC購買替換零件。
The trajectory is not steady. 彈道不穩定	<ol style="list-style-type: none"> Too much hop setting. hop旋鈕調整過度。 Inner Barrel or Hop parking contaminated by oil or dirt. 槍支內管或HOP橡皮內有灰塵或油污。 Worn or damaged hop parking. HOP橡皮磨損或毀壞。 Improper or too large size BB bullets. 使用不合適或太大的BB彈。 	<ol style="list-style-type: none"> 1. Gradually return adjustment lever towards normal. 漸趨調節使彈道平穩正常。 2. Clean the oil or dirt. 清潔灰塵或油污。 3. Purchase the replacement part at your dealer or from VFC. 向經銷商或VFC購買替換零件。 4. Use the quality BBs. 使用優質BB彈。

If you have any other states, please contact with your dealer or write the E-Mail for us service@vegaforce.com.tw
如果您有其它問題，請向您購買的經銷商聯繫或寄電子郵件至我們公司信箱service@vegaforce.com.tw