

※警告



限使用12kg瓦斯
(R22 / Green gas)



嚴禁存放於高溫環境
(Never store the Magazine above 40°C)



請勿接近火源
(Never place it near fire)



請勿烈日曝曬
(Never place it directly under sunshine)

□ Caution!

▲ PRECAUTION

NE PAS UTILISER D'AUTRES









PROJECTILEE QUE CEUX FOURNIS.

△ VORSICHT

Ausschliesslich für diese Pistole bestimmte

Munition verwenden.(6.0mm Kunststoffkugeln)

○ Fare attenzione

<p>○ ★ 射擊時最好戴護目鏡</p> <p>□ Be sure to wear shooting glasses or Goggle when shooting.</p> <p>▲ Toujours porter des lunettes de tir ou de protection quand vous tirez.</p> <p>△ Zum Schiessen stets eine Schutzbrille tragen.</p> <p>■ Asegúrese de llevar puestas las gafas de protección cuando dispara.</p> <p>○ Assicurarsi di indossare lenti di Protezione quando si spara</p> 	<p>★ 不用時要把槍置於高處 (小孩拿不到的高處)</p> <p>□ Put the gun beyond the reach of kids.</p> <p>▲ Tenir hors de portee des enfants.</p> <p>△ Pistole immer kindersicher aufbewahren.</p> <p>■ Ponga la pistola fuera del alcance de los niños.</p> <p>○ Tenere fuori Dalla portata dei bambini.</p> 
<p>× ★ 不可用眼睛探視槍</p> <p>□ Don't peep at the muzzle.</p> <p>▲ Ne jamais regarder dans le canon.</p> <p>△ Nie in den lauf schauen.</p> <p>■ Jamas mire por el canon</p> <p>○ Non guardare mai dentro la canna.</p> 	<p>× ★ 不可朝人射擊</p> <p>□ Don't aim at people even if it is unloaded.</p> <p>▲ Ne jamais viser quelqu'un meme si votre pistolet est vide.</p> <p>△ Auch bei spiel-und Sportwaffen besteht Verletzungsgefahr. Auch ungeladen nie auf einen Menschen oder ein Tier richten!</p> <p>■ No apunte a personas, incluso descargado.</p> <p>○ Non puntare mai verso le persone anche se la pistola scarica.</p> 
<p>★ 射擊的瞬間，才可以把手指接近扳機擊扣</p> <p>□ Don't touch the trigger until the moment of shooting.</p> <p>▲ Ne jamais appuyer sur la gachette le rearmement.</p> <p>△ Abzug erst dann berühren,wenn Sie zum Schiessen bereit sind.</p> <p>■ No toque el gatillo hasta el momento del disparo.</p> <p>○ Non toccare il grilletto fino al momento di sparare.</p> 	<p>★ 確定射擊的方向均安全後才可以射擊</p> <p>□ After making sure that there is nobody nearby.</p> <p>▲ Toujours etre sur qu'il n'y a personne dans la trajectoire de votre tir.</p> <p>△ Vergewissern Sie sich vor dem Schiessen stets, dass niemand getroffen werden kann.</p> <p>■ Antes de apuntar aseguese que no hay nadie cerca.</p> <p>○ Assicurarsi semper che non ci sia nessuno sulla traieitoria di tiro.</p> 
<p>× ★ 避免粗魯的動作，發生危險</p> <p>□ Avoid a rough operation.</p> <p>▲ Ne jamais jeter le pistolet quand il est arme.</p> <p>△ Geladene Waffe stets mit Respekt Behandln. Nicht werfen oder unsanft Jandhaben.</p> <p>■ No tire ni lance la pistola, se puede disparar.</p> <p>○ Evitare azioni brusche.</p> 	<p>★ 不使用時，應將彈匣取出，並取下子彈</p> <p>□ When the gun is not in use, remove the magazine and unload BB pellets.</p> <p>▲ Quand vous ne l'utilisez plus,bien Faire attention de retirer le chargeur et de le desarmer.</p> <p>△ Zum Aufbewahren Magazin entfernen und Kugeln herausnehmen.</p> <p>■ Cuando no se este utilizando la pistola, saque todas las bolas.</p> <p>○ Quando l'arma non e in uso, estrarre il caricatore e scaricare i pallini.</p> 

★ 正確使用空氣軟槍，可享受愉快的射擊，但是錯誤的使用方法非常危險，務必遵守注意事項。



WE GAS BLOW BACK TYPE
<http://www.wemodel.com.tw/>



鬥牛犬
BULLDOG

INSTRUCTION MANUAL



FOR AGE 18 YEARS OR OLDER

MADE IN TAIWAN

1 各部名稱 NAME OF PARTS

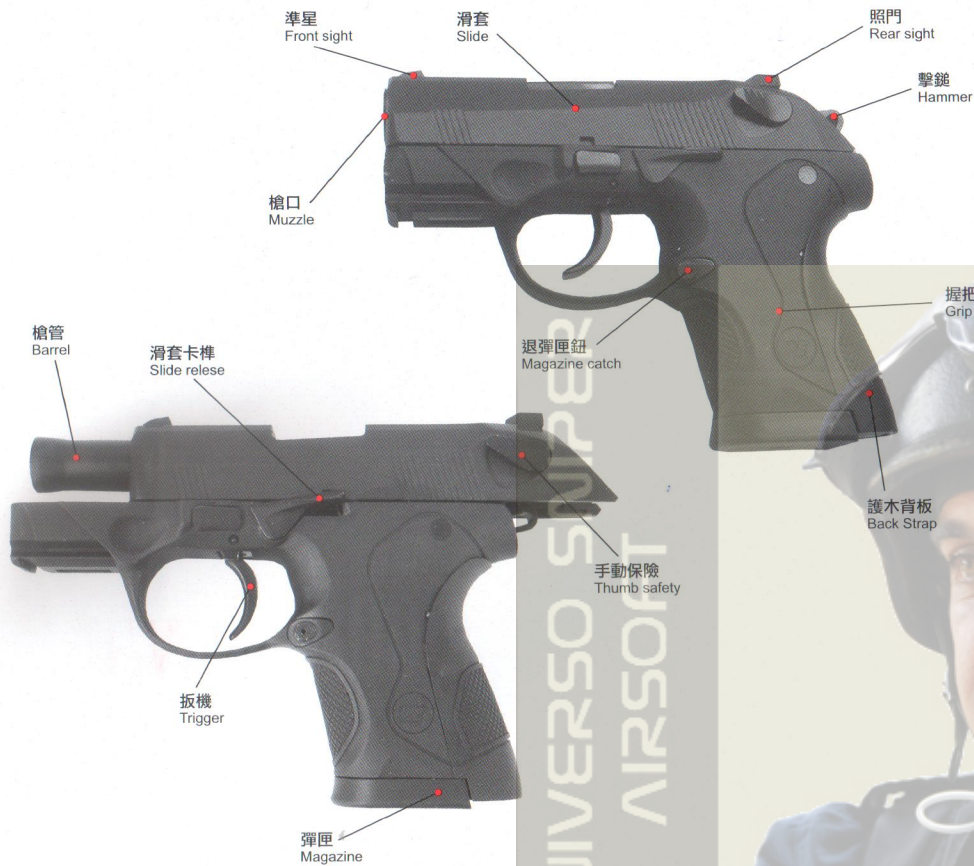

3 開關保險 SAFETY OPERATION

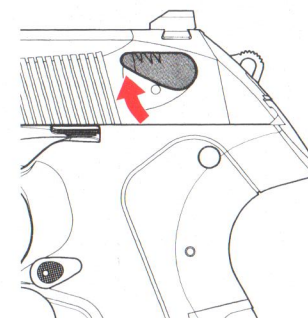
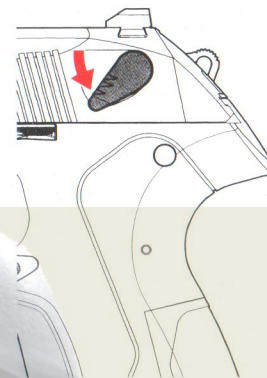

4 護木背板替換 CHANGE BACK STRAPS

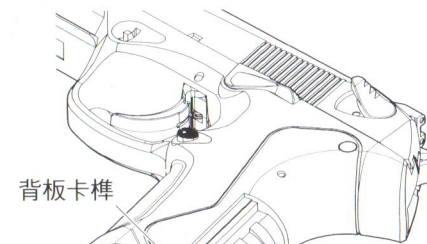
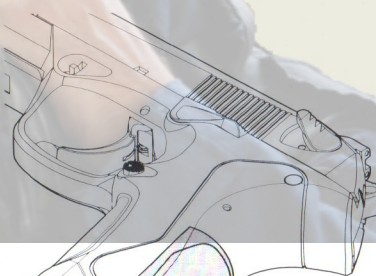

按下卡榫按鈕，即可鬆開背板，替換不同規格背板

SIZE : (S)

SIZE : (L)

2 彈匣裝填 MAGAZINE LODING

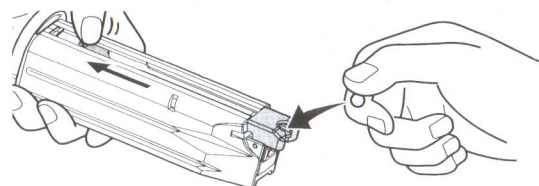

將瓦斯由彈匣底板中的瓦斯注入孔灌入。

12kg 瓦斯

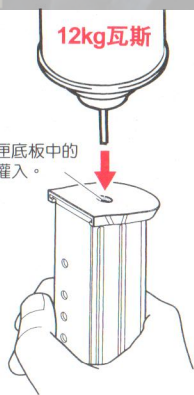

按下卡榫按鈕

5 上彈匣 LOADING & RELEASING THE MAGAZINE

■ 彈匣入退要點

入彈匣時推到底如聽“答”一聲即定位，押下彈匣卡筭，彈匣即會脫離 **注意：務必用手托住彈匣，以免造成掉落破損**

□ Load and release the magazine

While loading the magazine, push it inward to the bottom till a "tick" sound is heard. Press the magazine release catch, the magazine will fall off from the stock. **Attention: use hand to receive the magazine to prevent it from falling down to the ground.**

● El cartuche en posición correcta

Empuje la cartuche de balas hasta el final, y se oye el sonido "Tak". Así significa que está en su posición correcta Pulse el seguro del cartuche, y el cartuche se sale.

Advertencia: Sostenga el cartuche para evitar el dano.

○ Einsetzen und Herausnehmen des Magazins

Setzen Sie das Magazin ein, indem Sie es nach innen schieben, bis ein "Klicken" vernehmbar ist. Drücken Sie den Magazin freigabeverschluss. Das Magazin fällt aus dem Schaft heraus.

Achtung: Halten Sie das Magazin dabei mit der Hand fest, um Stürze zu vermeiden.

★ Inserire e rimuovere il caricatore

Mentre inserite il caricatore, premetelo fino in fondo sino a quando non sentite un "click". Premete il pulsante di rilascio del caricatore e questo cadrà automaticamente dal calcio.

Attenzione: prendete il caricatore con la mano per impedirgli di cadere in terra.



6 射擊 SHOOTING

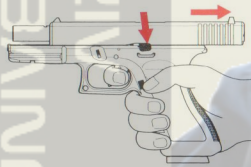
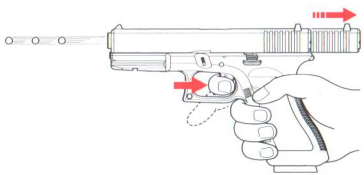

■ 初次裝填彈擊發時需先將滑套後拉使其BB彈上膛，擊扣扳機即可發射
注意：填充子彈以20+1發為限
BB彈發射完畢，滑套定位於後方此為無子彈之狀態，如欲繼續射擊填充子彈後下按滑套保險後上膛

□ When the slide is pulled back and released forward, the bullet is load-ed in the firing chamber, press the trigger to fire the loaded bullet.

Attention: The maximum containment for a magazine is 21 rounds. After the last BB bullet is fired, the slide will be retained in the back position, it means an empty magazine condition. If you want to resume the firing, insert a new fully loaded magazine, press the slide stop to release the slide and to reload the bullet.

● La primera vez que carga el cartuche, hay que jalar el deslizador hacia atrás.Y toque el gatillo para disparar.

Advertencia:La limitación de las balas es 21 unidades.

Cuando termina el disparo,el deslizador se queda atrás. Significa que está en posición de no bala.

○ Nachdem der gleitzug zurückgezogen und wieder nach vorn gesch-nellt ist,befindet sich ein abschlussbereites geschoss in der abschu-sskammer.Betätigen sie den abzug,um das geschoss abzuschließen. **Achtung:In ein magazin passen maximal 25 geschosse.**
Nachdem das letzte BB-geschoss abgefeuert wurde, geht der gleit-zug zurück in die rückwärtige position. Dies bedeutet, das magazin ist leer. Falls sie weiter schießen wollen, so setzen sie ein neues,voll geladenes magazin ein. Drücken sie auf den gleitzugstopp, um den gleitzug freizugeben und geschosse nachzuladen.

★ Tirato indietro il carrello e poi lasciatolo tornare avanti,il proiettile è caricato nella camera di scoppio, a questo punto premete il grilletto per sparare il proiettile caricato in canna.

Attenzione:Un caricatore può contenere al massimo 25 colpi.
Sparato l'ultimo proiettile BB, il carrello rimane nella posizione poste-riore,ad indicare che il caricatore è vuoto. Se volete continuare a s-parare,inserite un caricatore pieno e premete il pulsante di sblo-cco del carrello per rilasciarlo e ricaricare un proiettile.

7 射擊過程 SHOOTING PROCESS

■ 長時間連續發射容易使彈匣過於低溫，影響氣體壓力及子彈初速，此為正常現象非故障所致擊發時請勿倒轉擊發此動作無法使氣體揮發產生霧氣噴出容易導致零件耗損

□ After a long and continued firing practice,the low temperature of the magazine will cause a reduced gas pressure as well as the low velocity of bullet. It is a normal condition, not a trouble.Never practice the reverse firing for this action renders the gas hardness to volatilize and to produce the atomized gas of ejection which leads the damaged to the parts.

● Si quiere continuar el disparo, rellene el cartuche y jala el deslizador hacia atrás como el paso anterior.El disparo continuo hace el cartuche de balas en temperatura baja, y afecta a la presión del aire y la veloci-dad de bala. Eso es normal.

○ Nach längerem, ununterbrochenem Schießen passiert es, dass die Temperatur im Magazin absinkt und dadurch der Gasdruck wie auch die Geschossgeschwindigkeit abnimmt. Dies ist eine normale Erscheinung und kein Anlass zur Sorge.Halten Sie das Gerät beim Schießen nicht seite-nverkehrt (d.h. Lauf nach unten)Dies kann zu Gasverflüchtigung und Beschädigung der Einzelteile führen.

★ Dopo una lunga e prolungata sessione di sparo, la bassa temperatura del caricatore comporterà una riduzione della pressione del gas e diminuirà velocità dei proiettili. Si tratta di una condizione normale, non di un guasto.
Non provate mai a sparare con il fucile al contra-rio, dato che questa azione fa volatilizzare la densità del gas e produce perdite di gas atomizzato che possono danneggiare i componenti.

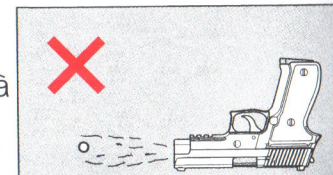
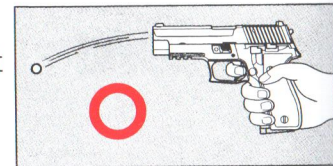

8 分解及保養 DISASSEMBLY AND BASIC MAINTENANCE

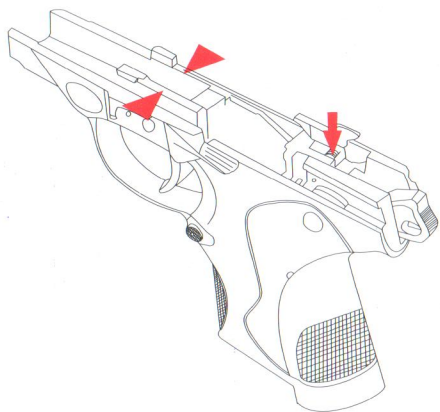
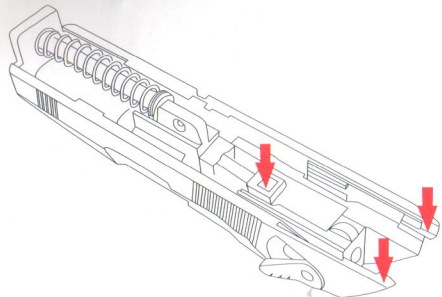
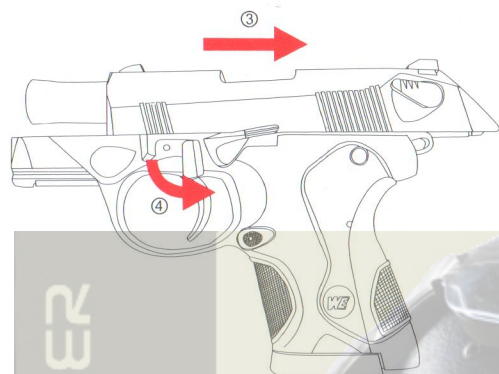
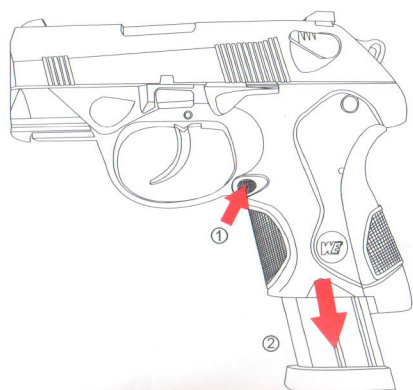

※標示處請上油保持潤滑



9 爆炸圖 EXPLOSION

