



CA SCAR

Close Quarter Combat

CA C.Q.C.

HANDLING CAUTIONS AND INSTRUCTION MANUAL



WARNING

- FOR AGE 18 OR ABOVE.
- PLEASE READ THE INSTRUCTIONS CAREFULLY BEFORE USE. MISUSE OR CARELESS USE MAY CAUSE SERIOUS INJURY.
- USER SHOULD OBEY TO THE LAWS REGARDING THE USAGE AND OWNERSHIP OF AIRSOFT ELECTRIC GUNS.
- FACIAL PROTECTION IS REQUIRED.

CA023P

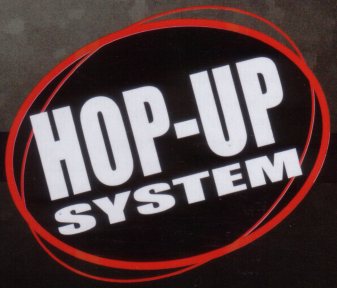

Produced By Classic Army, Hong Kong

1 Outlook/Structure

Always set the selector switch to the safe position when you are not firing or during storage

CA SCAR C.Q.C. (Close Quarter Combat)

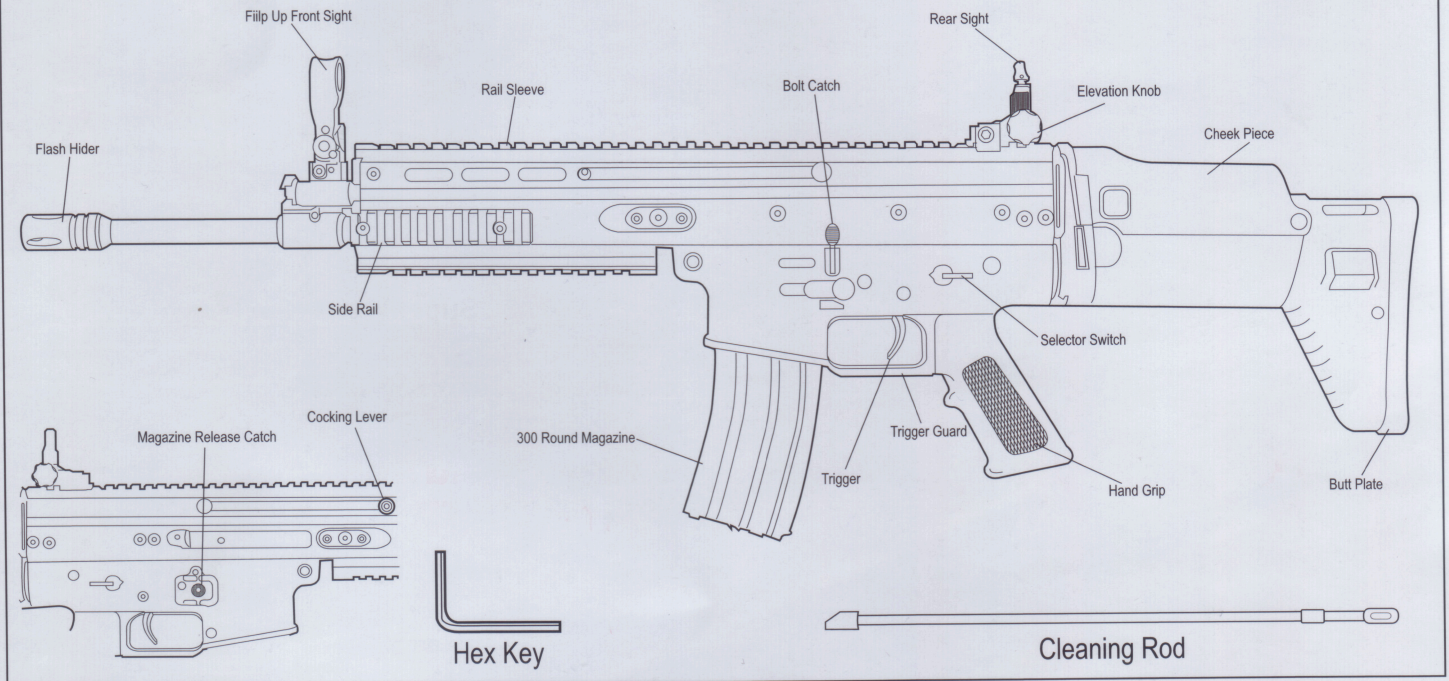

2 Specification

Data of Automatic Electric Gun

Name	CA SCAR C.Q.C. (Close Quarter Combat)	
Weight	3.5 kg	
Barrel Length	384mm	
Barrel Caliber	6.08mm	
Pellet Capacity	300	
Pellet	6mm BB	
Initial Pellet Speed	85-105 m/s	
Battery Type	Mini Type (8.4 v)	

3 Operation

1 How to use safety lock

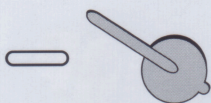

S : Safety Lock

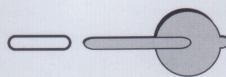

E : Semi Auto



F : Full Auto

2 How to insert battery

CAUTION Be careful with your fingers.

Set the battery after charging

1 Push the button and flip out the stock.

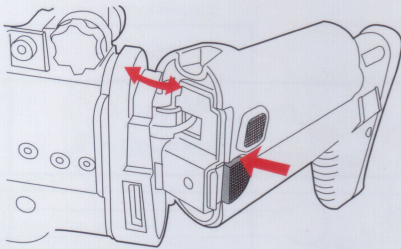

2 Release the screw with a 3mm hex key then press the stock button and pull out the lower part.

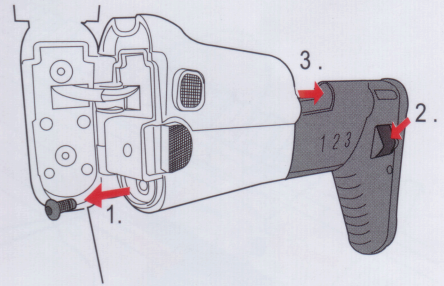

3 Take out the connector and connect it with the battery.

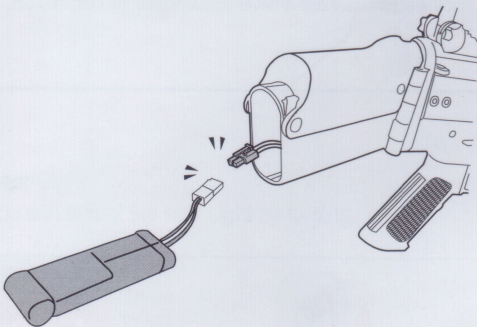

4 Insert the battery into the stock.

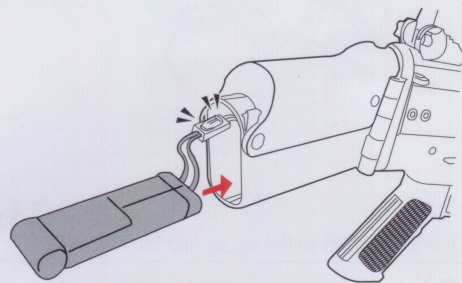

3 Magazine Attachment / Detachment Procedure

High precision is required for the operation of this magazine. Avoid invasion of dust and dirt into the magazine to prevent malfunctions.

Action against problem
Failure in pellet feeding may occasionally occur during full auto operation. In this case, disconnect the magazine, give a slight shock or poke BB pellets using a stick and then set the magazine again.

CAUTION

About 30 pellets will remain in the duct after operation. Be careful of any pellets firing out if you hold the gun up-side-down and pull the trigger.

Ensure smooth pellet feeding

- Occasionally give slight shocks to the gun or shake vertically for ensuring smooth pellet feeding.
- Slightly turn the gear after every 50 to 60 pellets to ensure smooth pellet feeding.

1. Press the magazine catch to detach the magazine

2. Open the top hatch and insert BB pellets. About 190 pellets can be loaded. (Avoid forcing BB pellets into the magazine.)

3. Close the hatch

4. Hold the Magazine with BB pellet entrance facing upward. Turn the gear at the bottom all the way until the click-click sounds change. (If only a small number of BB pellets are inserted, the gear merely makes blank turning.)

5. Check the BB pellets whether they are lifted up to the exit, and then connect the

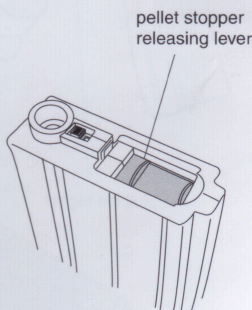
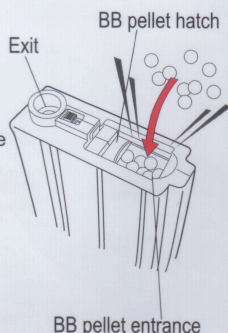
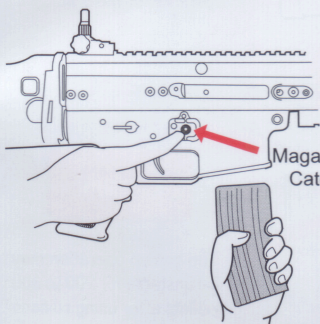

Turn the gear all the way until the sound changes.

The gear will not be damaged even if you turn it excessively.

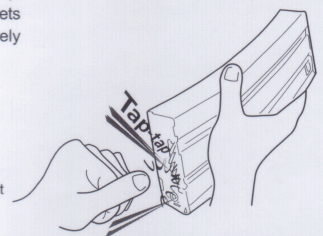

Remove pellets remaining in the duct by reversing the magazine and using the release lever as shown. This ensures smooth operation next time.

If pellet feeding is frequently in fault, remove all pellets from the magazine and spraysilicone oil for 1 to 2 sec. Note that the hop-up operation may become unstable for a while after using silicone oil.

4 Adjust the Hop-Up

1 Adjust the Hop-up Chamber

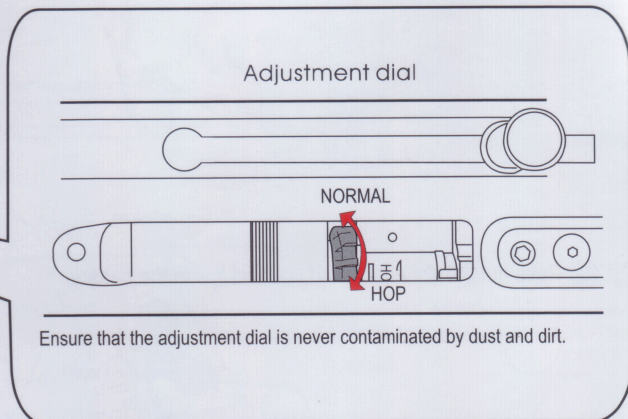
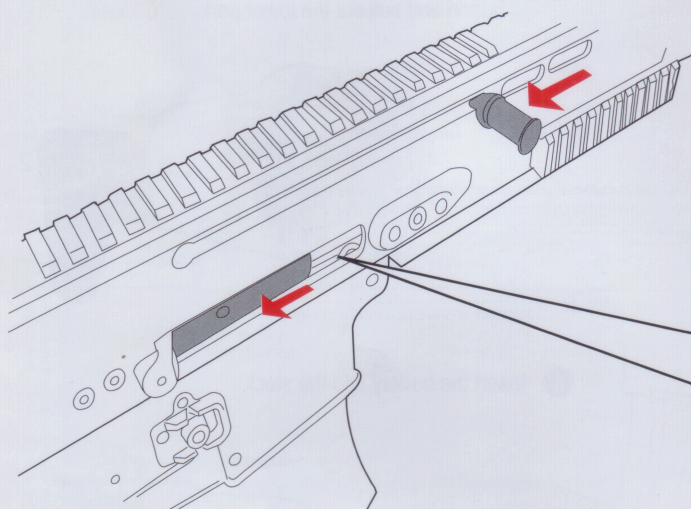

5 How to fire

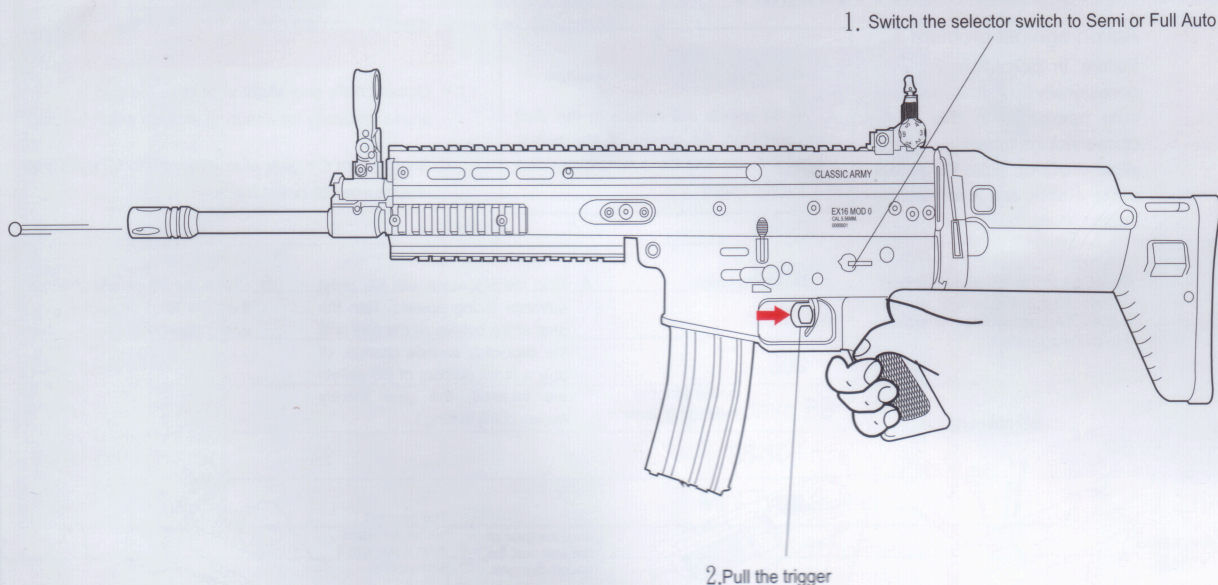

- There are possible cases that no firing occurs after pulling the trigger in the semi auto mode. In case, do not pull the trigger furiously. Fire 5 to 10 pellets in the full auto mode and then return to the semi auto mode.



- Smell may be generated from the motor for a while when a new air gun is operated, this is the normal operation of the gun.



- The hop up operation may be unstable for 200 to 300 pellets after using silicone oil, this is the normal operation of the gun.

* Blank firing may occur after setting the magazine, this is the normal operation of the gun.

Cautions on Motor and Battery

- Change the battery if the firing cycle becomes slow.
- Give the air gun a rest for 5 to 10 minutes after firing about 500 pellets in order to ensure high durability of the motor and battery.

When pellets are clogged

- Remove them and apply a few drops of silicone oil into chamber from the magazine entrance as shown or spray silicone oil for 0.5 to 1 sec, to obtain smooth continuous firing. (Never use CRC-556 or other mineral oil)

6 Sight Adjustment

1 Front Sight :
Setting the point of impact.

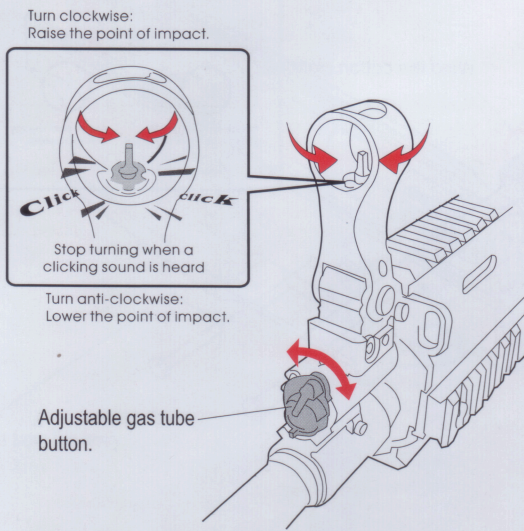

2 Front Sight :
Push the small button on the right and then you can flip down the sight.

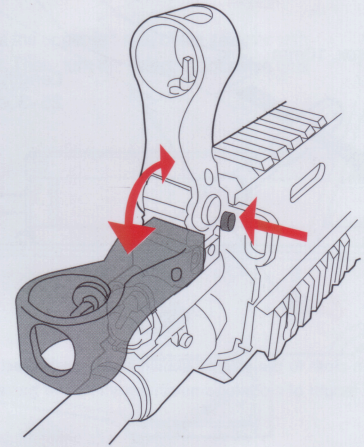

3 Rear Sight :
You can adjust the rear sight by turning.

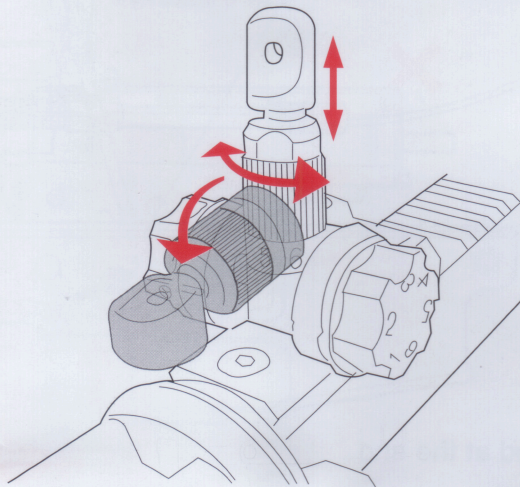

4 Rear Sight :
The rear sight can move left or right by turning the knob.

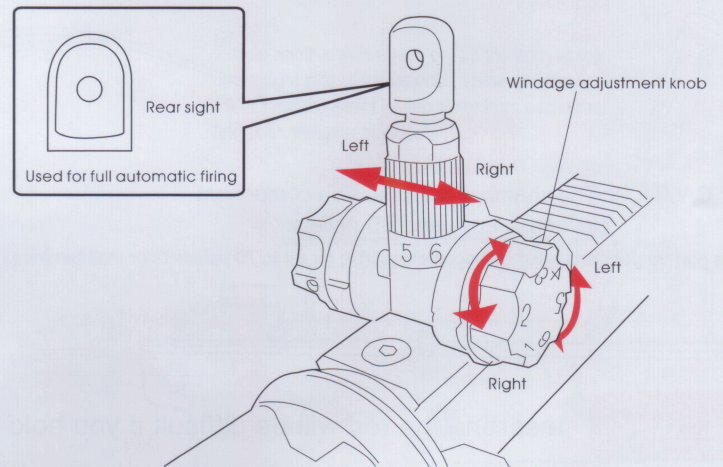

5 Press the button to raise up & down the cheek piece.

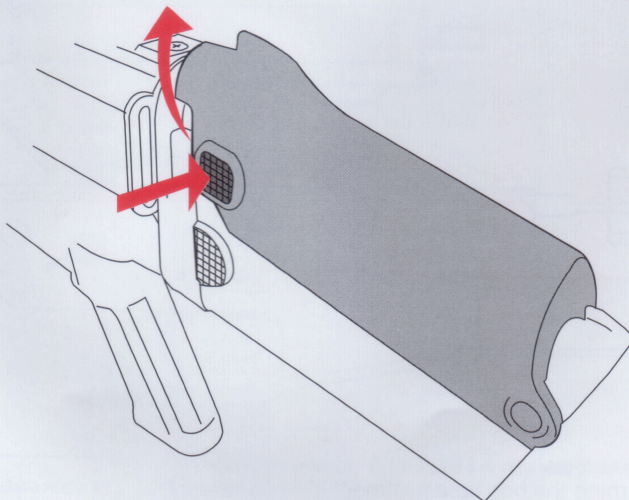

4 Maintenance

1 How to use a cleaning rod

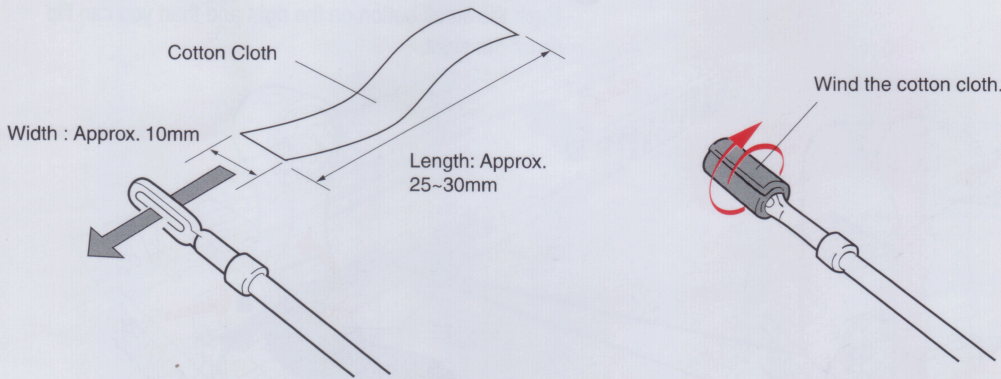

CAUTION Never use any used BB pellets

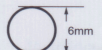

Use new 6mm BB pellet is a must



Please don't use any BB pellet which is not completed.



Please don't use any broken BB pellet.



Please don't use any BB pellet which diameter exceed 6mm.

Cut a cotton cloth to the size as shown above and insert one end into the hole in the rod.
(Adjust the length of cloth for smooth entry into the barrel.)



CAUTION: Always begin the maintenance by returning the hop up adjustment lever to NORMAL



CAUTION: The chamber is a precision component.
Never use any used BB pellets.

* The hop-up performance may become unstable for 60 to 70 pellets after maintenance.

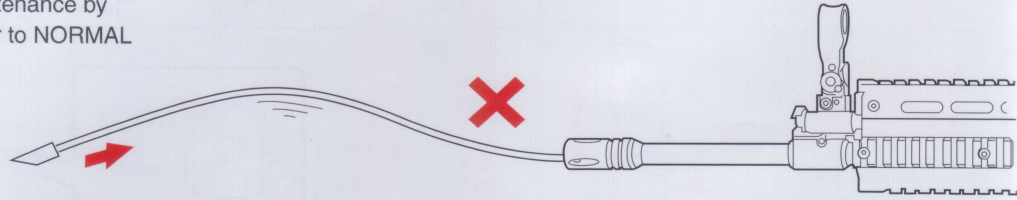

Inserting the rod will be difficult if you hold the rod at the end.

- 1 Spray silicone oil for 0.5 to 1 sec in the pellet entrance, then fire 40 to 50 pellets to make the magazine stable.
- 2 Clean the oil from the chamber using the cleaning rod (with cotton) to complete the maintenance.

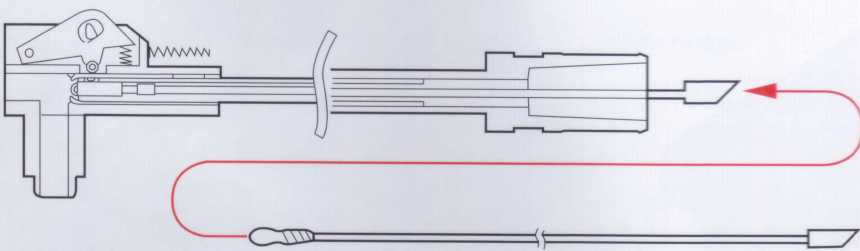

CAUTION: Always begin the maintenance by returning the hop up adjustment lever to Normal.

20A Glass Tube Fuse is used

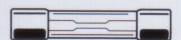

5.1 How to disassembly the gear box from the lower receiver

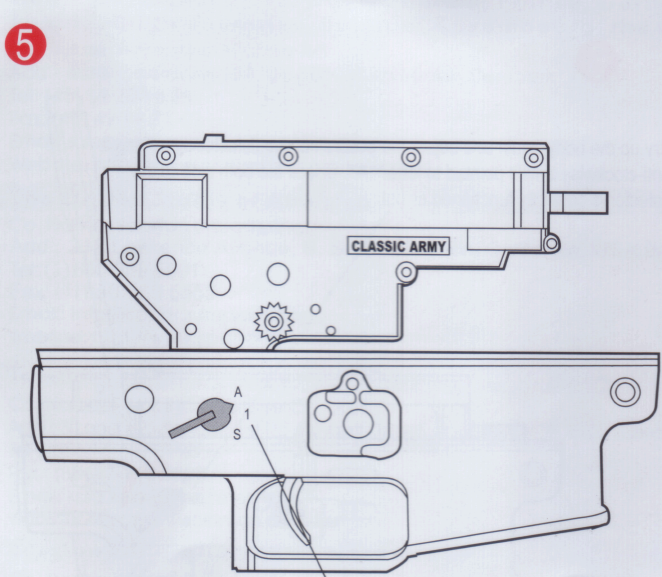
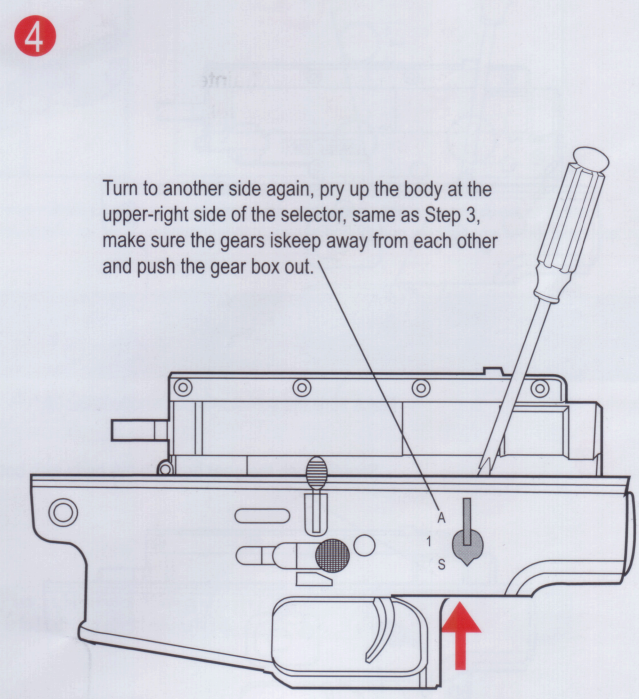
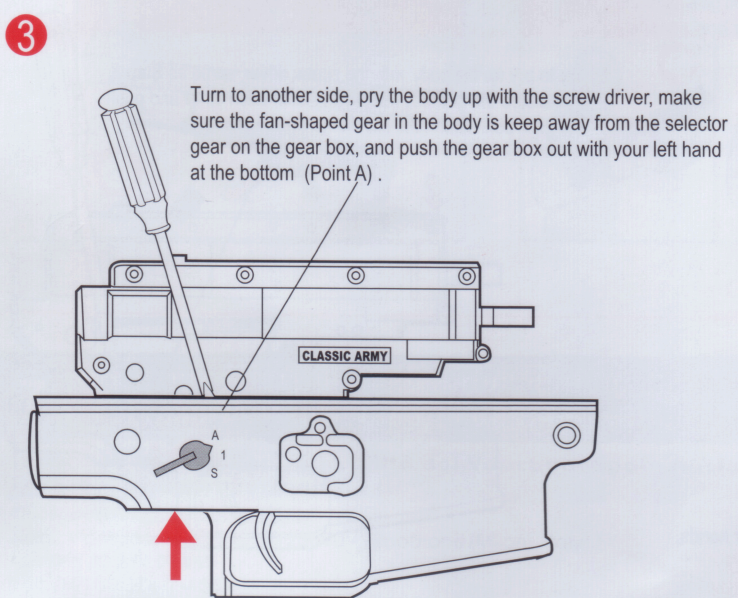
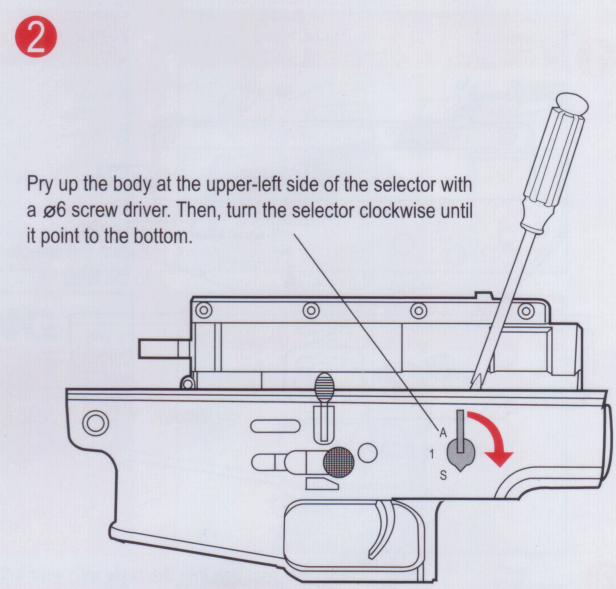
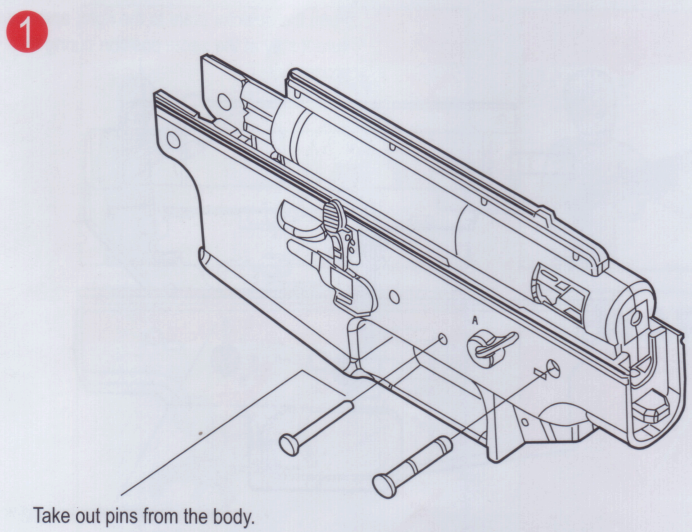

Take out the gear box , if you found it is very hard to take it out, repeat Step 3 and 4 .

5.2 How to assembly the gear box into the lower receiver

- 1**

Switch the selector and point to the letter 'A'.
- 2**

Push the selector plate to the right, and make sure it stay at the same position during this process.

Switch the selector and point to the bottom.
- 3**

Slightly push the gear box into the body with your left hand, pry the body up with the screw driver, make sure the fan-shaped gear in the body is keep away from the selector gear on the gear box, and push the gear box into the body.
- 4**

Try to pry up the body with the screw driver, same as Step 3, make sure the gears is keep away from each other and push the gear box. Then take out the screw driver.
- 5**

Make sure the selector is pointing to letter 'A'.

Slightly push the gear box into the body with both your hands.
- 6**

Pry up the body again and adjust the position of the selector by turning it anti-clockwise until it pointed to letter 'A'. Check the both side of the selector is correctly functioned or not.
- 7**

Insert the pins into the body.

6 WARNING

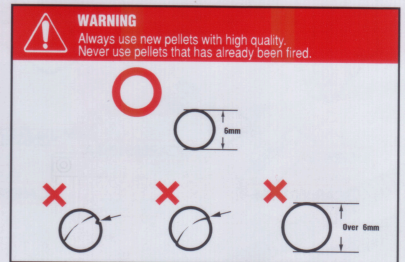
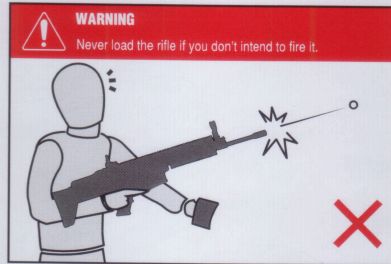

In no event shall Classic Army or any of our partners be liable for any direct or indirect, special, incidental, or consequential damages in connection with the use of our products.

7 For complete product information, dealer locations and technical support, please visit the website of Classic Army Sole Distributors .

Italy, San Marino Republic, Città del Vaticano, Spain (includes Andorra and Gibraltar) Portugal and Switzerland

Co. Name: VI.SE.LE Italiana S.r.l.
 Add.: Via Walter Tobagi n.13, 20090 - Vimodrone (Milan), Italy
 Tel: (39) 02 274 09455
 Fax: (39) 02 274 09455
 Email: visele@classicarmyitalia.com
 Website: <http://www.classicarmyitalia.com/>

Denmark, Sweden, Norway & Finland, France, Germany, Austria, United Kingdom, Poland, Baltic countries, Belgium, Luxembourg, the Czech Republic and Slovakia

Co. Name: ActionSportGames A/S
 Add.: Bakkegaardsvej 304, DK-3050 Humlebaek, Denmark
 Tel: (45) 89 28 18 88
 Fax: (45) 49 19 31 60
 Email: sales@actionsportgames.com
 Website: <http://www.actionsportgames.com/>

The United States of America

Co. Name: Spartan Imports, Inc.
 Add.: 213 Lawrence Avenue, S. San Francisco, California, USA 94080
 Tel: (1) 650 589 5501
 Fax: (1) 650 589 5552
 Email: info@spartanimports.com
 Website: <http://www.spartanimports.com/>

Taiwan

Co. Name: F-Link Int'l Enterprise Co. Ltd.
 Add.: 3 Lane 62, Jianguo 1st Rd., Lingya District, Kaohsiung City 802, Taiwan, R.O.C.
 Tel : (886) 7-710 0198
 Fax : (886) 7-710 0398
 Email: kssa.kssa@msa.hinet.net
 Website: <http://www.soloman.com.tw/>

Russian Federation and Belorussia

Co. Name: Uragan Limited.
 Add.: Novorogozhskaya str. 12/3 Moscow 107954 Russia
 Tel : (7) 495 323 5366
 Fax : (7) 495 323 5366
 Email: toybike@yandex.ru
 Website: <http://www.classicarmy.ru/>

8.1 Exploded Diagram

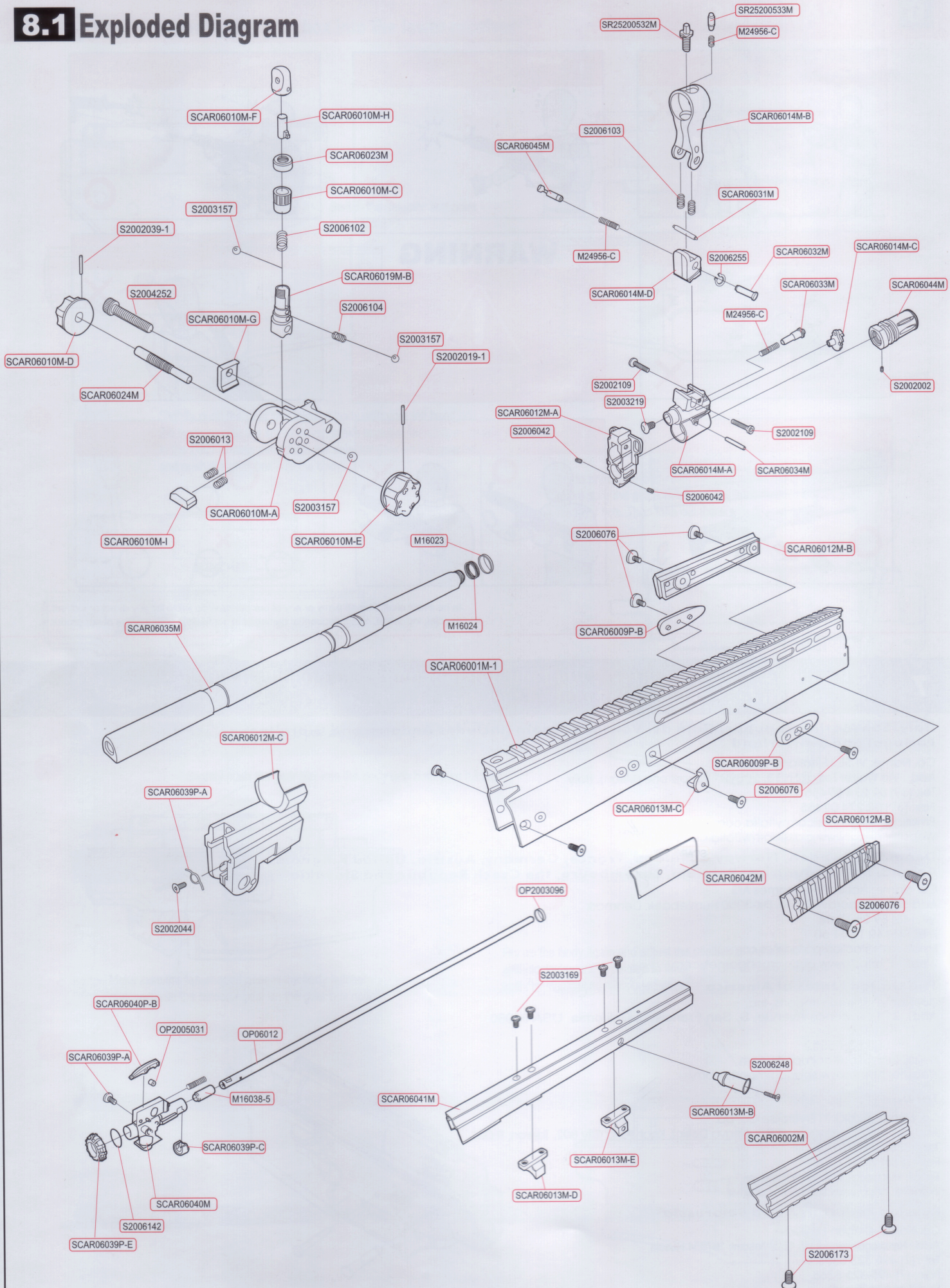

SCAR CQC

CLASSIC ARMY
14mm Double Screw Silencer
SER. NO. A084M-07182003



CLASSIC ARMY

Website : www.classicarmy.com

E-mail : info@classicarmy.com