

電槍使用之注意事項

- 請勿使用回收及劣質的 BB 彈，以減少槍管損耗與避免卡彈的情形發生。
- 如發現有卡彈的情形，應立即停止射擊，如卡彈後再勉強射擊，則會增加齒輪損耗。請使用內附通槍條，將卡彈清除後才可繼續使用。若完成通槍基本故障排除後仍無法使用時，請回原採購店家或專業經銷商尋求維修服務。
- 使用前請先確定您的電池已充滿電，當使用中發覺電池即將用盡或射擊速度降低時，應立即更換電池。
- 請定期使用通槍條清潔槍管，以保持槍支射擊時的準確性及減少卡彈的情形發生。
- 請勿經常空槍射擊，以減少 BOX 及齒輪不必要的損耗。

Maintenance

- Use high quality BB's to prevent further damage to the AEG and to stop jams.
- When a BB is jammed, take the cleaning rod that came with your gun and push it into the barrel moving down gently until the jammed BB comes loose.
Note: The barrel does not need to be removed from the gun before unjamming a BB.
- To keep the outer appearance maintained, wipe down the gun with a soft cloth.
- Do not dry fire the gun at any time to reduce damage to the gear box.
- After playing, remove the magazine, switch to single shot mode and fire one shot to release the spring within the gearbox. Finally disconnect the battery. Clean and lubricate your AEG before storage, as needed.

基本故障排除 Troubleshooting Guide

狀況 Status	原因 Cause	處理方法 Action
完全無動作 No operation at all	選擇鈕位於關保險的位置。 Selector lever is set to Safety position.	將選擇鈕切換至單發或連發狀態。 Set the selector lever to Semi or Full Auto.
	電池未充電。 Battery is not charged.	將電池充至滿電狀態。 Fully charge the battery.
	電池接頭未接好或正、負極接反。 Battery connector is disconnected or reverse.	將電池接頭及正、負極確實接好。 Connect the connector correctly.
	保險絲鬆脫或燒掉。 Fuse is fall off or blown down.	將保險絲接頭重新接好或更換新的保險絲。 Connect the fuse connector or replace fuse.
	馬達線材接觸不良。 Poor motor electrical connection.	重新接過或更換新線材。 Check and repair the connector.
	馬達壽命已耗盡。 Expired motor life.	更換新馬達。 Replace the motor.
馬達有轉動，但沒有子彈射出。 Although the motor is revolving, no bb's fire out.	子彈在彈匣內，未就擊發定位。 Magazine is not fully seated into the receiver.	撥轉彈匣下方發條轉輪，使其實力將 B.B 彈送至擊發定位。若轉動後仍無法射擊時，請回原採購店家或專業經銷商尋求維修服務。 Load the magazine into the receiver and wind the wheel, if it still doesn't work, please contact your service technician or ask us for assistance.
	子彈卡在 Hop-up 或槍管中。 Bullets are jammed in Hop-up system or barrel.	使用通槍條將阻塞的子彈清出。 Using the cleaning rod to remove jammed bullets.
	齒輪損壞，導致空轉。 Faulty gear. 撥彈彈桿斷裂。 Tappet plate is broken.	請回原採購店家或專業經銷商尋求維修服務。 Please contact your service technician or ask us for assistance.
連發無法射擊 Full-auto not working	電池電量不足。 Insufficient battery power.	電池充電。 Fully charge the battery.
	送彈失敗。 Faulty bullets feed from the magazine.	清除阻塞的子彈。 Clean the jammed bullets.
單發無法射擊 Semi-auto not working	齒輪未正確到位。 Deviation in gear timing.	連發射擊 5-6 發子彈後再切換至單發，讓齒輪到達正確位置。 Fire 5-6 rounds in full auto then switch the selector lever to Semi.
	電池電量不足。 Insufficient battery power.	將電池充電。 Charge the battery.
	送彈失敗。 Faulty bullets feed from the magazine.	清除阻塞的子彈。 Clean the jammed bullets.
子彈在槍管前端即掉落 BB's roll out barrel	Hop-up 磨損或槍管氣密有問題。 Hop-up or barrel damaged.	請回原採購店家或專業經銷商尋求維修服務。 Please contact your service technician or ask us for assistance.
	B.B 彈品質不良。 Faulty or poor quality BB bullets.	更換 I.C.S 原廠高品質 B.B 彈。 Use ICS high quality BB's.
射程變短 Shooting distance greatly reduced	Hop-up 磨損或槍管氣密有問題。 Hop-up or barrel damaged.	請回原採購店家或專業經銷商尋求維修服務。 Please contact your service technician or ask us for assistance.
	活塞或 O 環磨損。 Piston or O-ring are damaged.	
	活塞彈簧疲乏或損壞。 Deteriorated piston spring.	
	齒輪故障。 Gear problem caused by excessive dry firing.	更換 I.C.S 原廠高品質 B.B 彈。 Use ICS high quality BB's.
射擊時聲音變大 Loud operating noise	齒輪過度磨耗或已破損。 Damaged gear.	請回原採購店家或專業經銷商尋求維修服務。 Please contact your service technician or ask us for assistance.
	馬達間隙走位。 Problem caused by the engagement between the motor and gears.	請勿任意調整馬達間隙，以確保最佳運轉狀態。 Don't tune the engagement between the motor and bevel gear yourself! contact your service technician or ask us for assistance.
槍身浸水或淋到雨 Gun is very wet or has been immersed in water.	請立即停止使用並將電池卸下，待整把槍及電池完全乾之後，再裝上電池測試是否故障。若發生無法正常使用時，請與原採購店家或專業經銷商尋求維修服務。 Stop operation immediately and disconnect the battery, Wipe off any excess water from inside the body and from the battery. When the AEG is completely dry, test fire. If no operation or signs of a malfunction is suspected, please contact your service technician or ask us for assistance.	

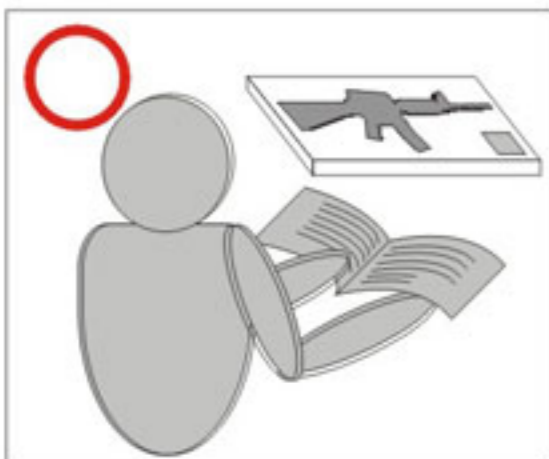

使用槍枝前請先閱讀使用說明書。
Always read through this manual before operation.



射擊時請戴上護目鏡以確保安全。
Always wear eye protection during use.

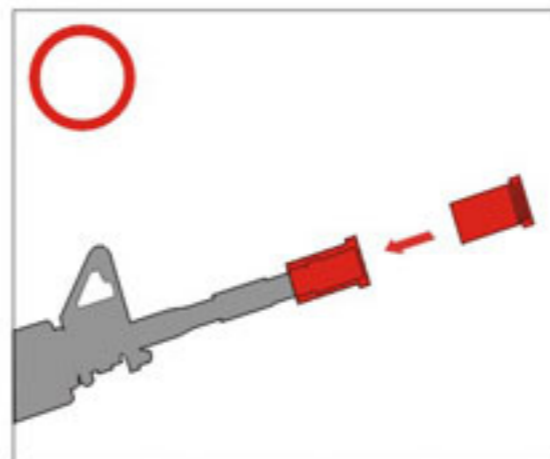

不使用時請蓋上保護蓋以防有異物進入槍管內。
Always attach the protective cap to the muzzle when not in use.

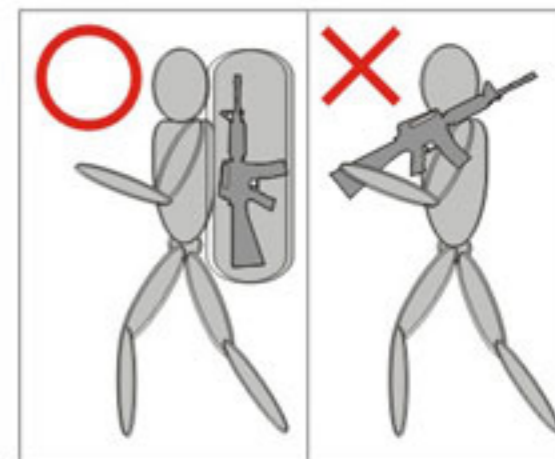

帶槍枝外出時，請用槍袋包裝好。
Always store the AEG in a case or bag when you are carrying it.



絕對不可以由槍口探視，避免傷及眼睛。
Never look into the gun's muzzle.

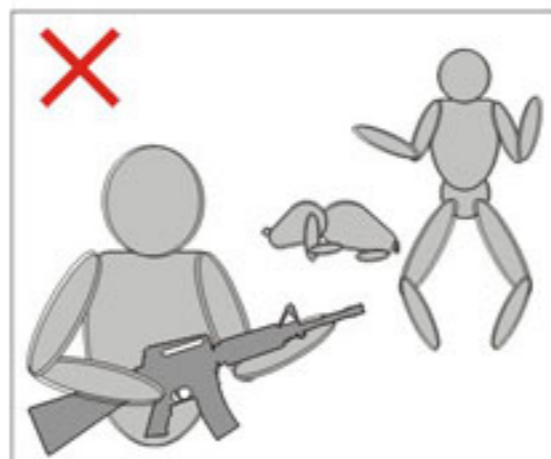

槍口不可指向人或動物。
Never direct the muzzle towards animals or people.



請勿將槍置於未滿使用年齡之孩童容易取得之處。
Store the AEG out of the reach of children.

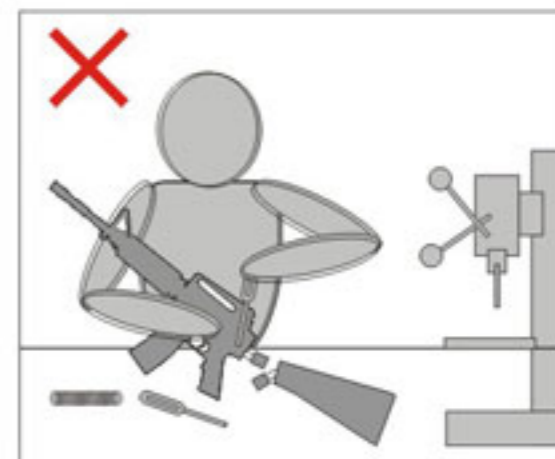

請勿任意將槍枝分解加工、改造。
Never disassemble or modify the AEG.

使用前請詳讀說明書，務必嚴格遵守“注意事項及使用方法”。
Read this manual before operation. Operate the Air Gun with full "recognition of warnings and cautions."

警告 WARNING

- 1 這個產品是針對 18 歲以上的消費者所開發的休閒運動的電動槍，請務必遵守遊戲規則。
- 2 為避免讓別人誤認為真槍，帶槍外出時，請將槍以槍袋包裝，以避免不必要的誤會。
1. You must be 18 years or older to purchase and use this Air Gun. Carefully read and understand these instructions before use.
2. Since this Air Gun maybe mistakenly identified as a real firearm, you should never point the Air Gun towards a person in public so as to avoid serious consequences from armed law enforcement officers.

各部名稱
Component names



型號 Model	重量 Weight	長度 Length	彈匣裝彈數量 Bullet	初速 Velocity	子彈 Caliber
固定托 Fixed stock	3000 g	970 mm	550 發 550 Round	90-100 公尺/秒 90-100 M/S	6 mm BB



裝電池方法
Battery fitting method

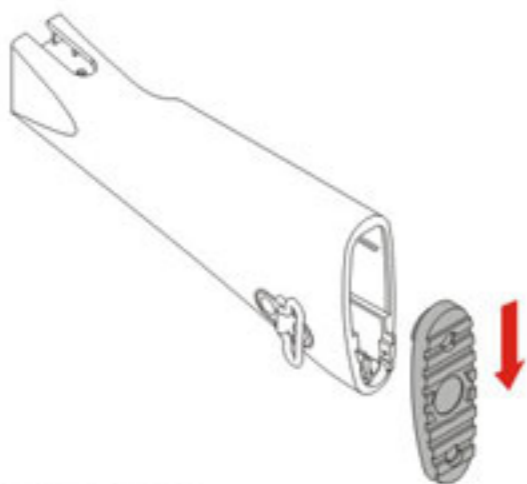

將槍托底板蓋打開。
Remove the butt plate by pressing it downwards.

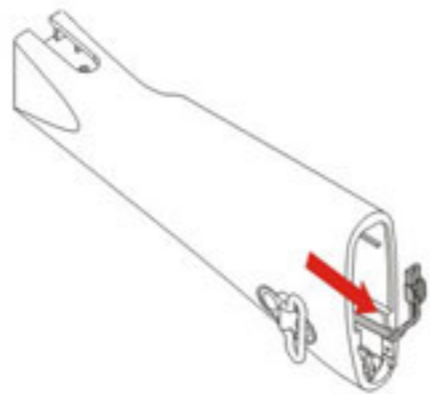

拉出電線。
Pull out the connector.

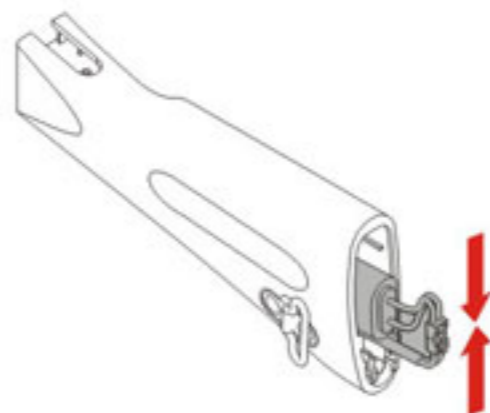

將電池裝入接上電線。
Insert the battery into the stock as shown and connect the battery.

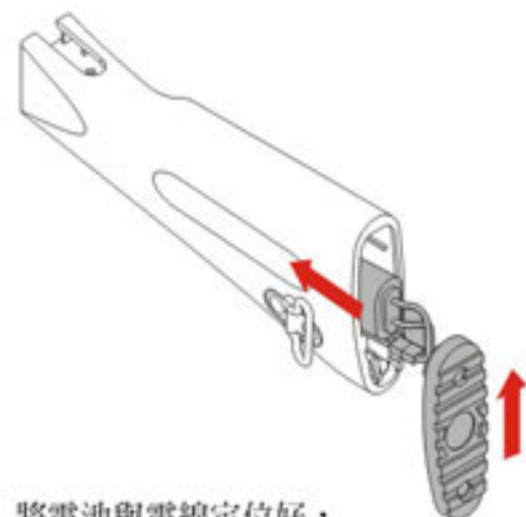

將電池與電線定位好，再蓋上槍托底板蓋。
Ensure the connectors are also located inside the stock then attach butt plate by pushing upwards.

覘孔調整方式
Rear sight adjustments

遠距
Long distance

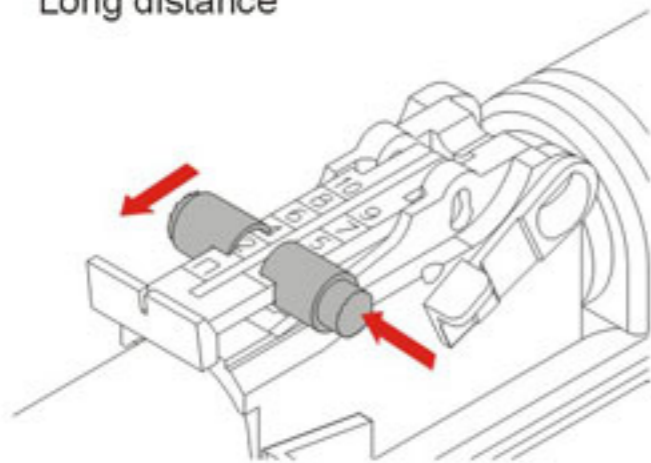

將覘孔調整鈕往後拉，卡住射擊所需的刻度。
Press the adjusting button and slide it backward to the suitable index.

近距
Short distance

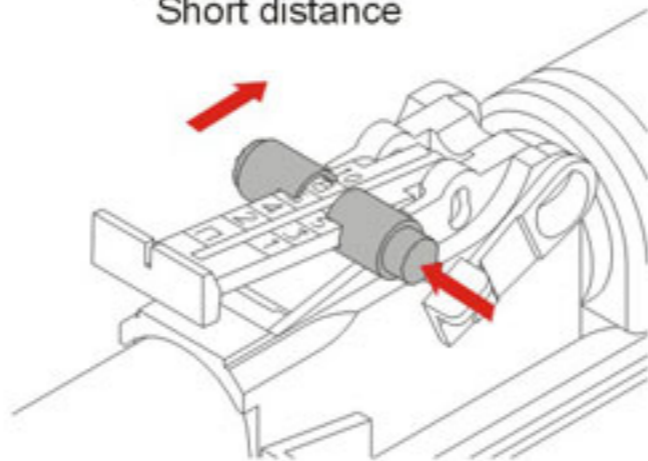

將覘孔調整鈕往前推，卡住射擊所需的刻度。
Press the adjusting button and slide it forward to the suitable index.

準星高度調整
Bear sight and front sight adjustments

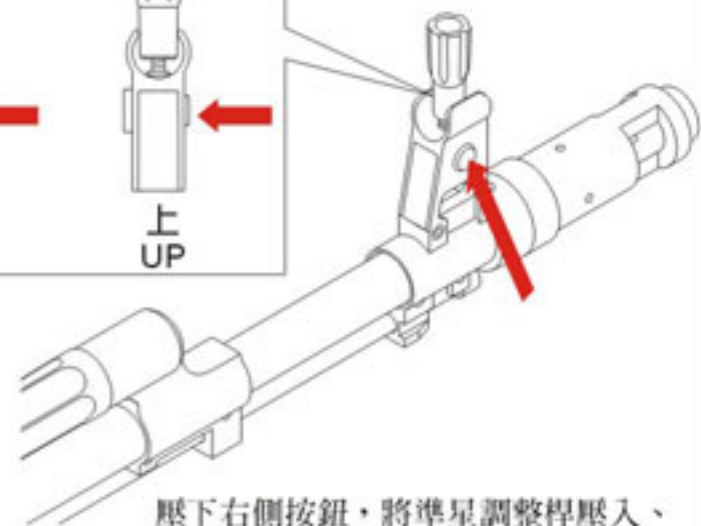
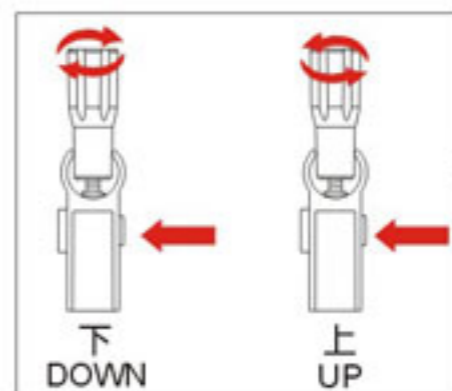

壓下右側按鈕，將準星調整桿壓入、定位轉動即可調整高低。
Press the right side button and insert the sight adjustment tool in the front sight and tum it for adjustment.

可動部位說明
Moveable parts

上護木
Upper handguard

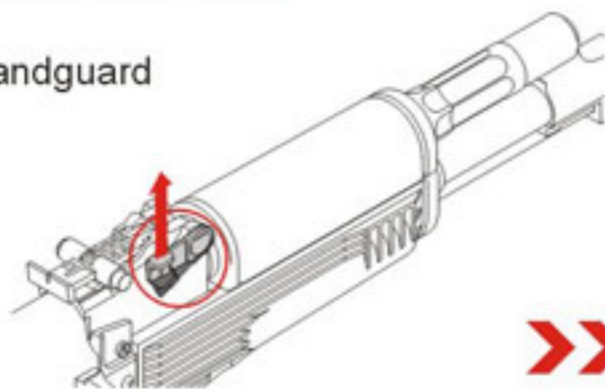

將上護木環固定鈕扳起。
Lift up the upper handguard fixed lever.

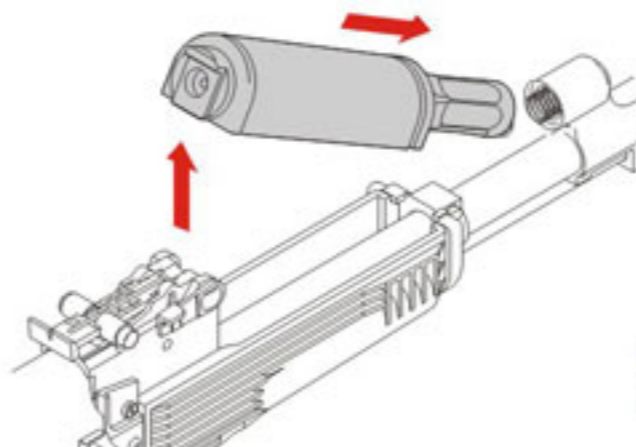

將上護木環整個往上拉，上護木即可卸下。
Lift and disassemble the upper handguard.

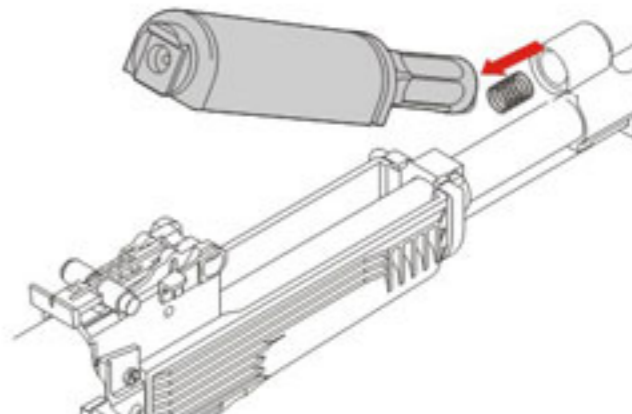

上護木卸下即可取出彈簧。
Remove the upper handguard and remove the spring.

下護木
lower hand guard

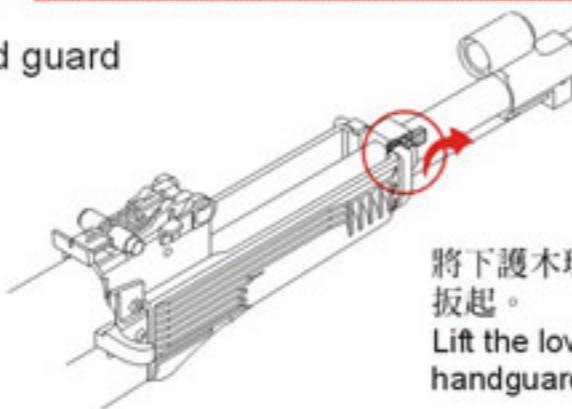

將下護木環固定鈕扳起。
Lift the lower handguard fixed lever.

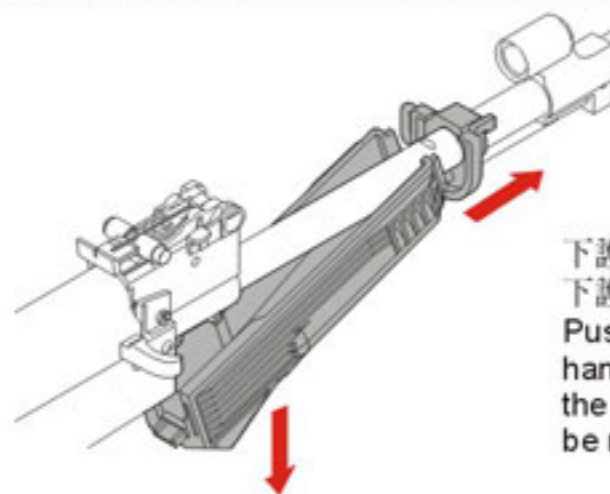

下護木環整個往前拉，下護木即可卸下。
Push forward the lower handguard ring and then the lower handguard can be removed.

馬達間隙調整
Fine adjustment of gear engagement.

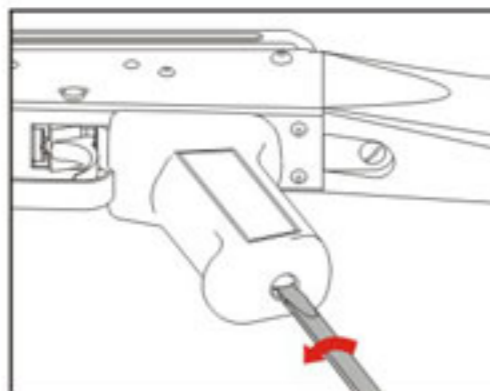

以一字起子將握把螺絲鬆開。
Remove the screw from the bottom of the pistol grip.

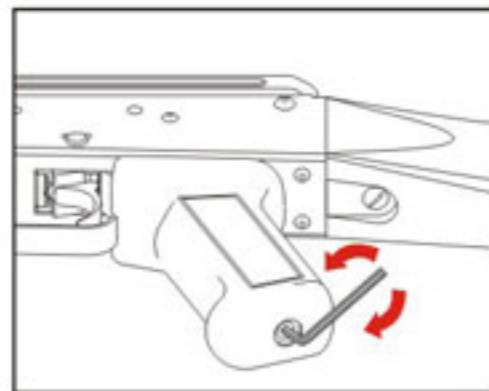

以六角板手將馬達齒輪間隙調整到最佳位置，請勿自行調整。
Use a hexagonal allen wrench to fine tune the engagement between the motor and bevel gear. Don't adjust yourself.

齒輪箱拆卸
Gear box



1

按下機匣蓋開關。
Press the top receiver catch button

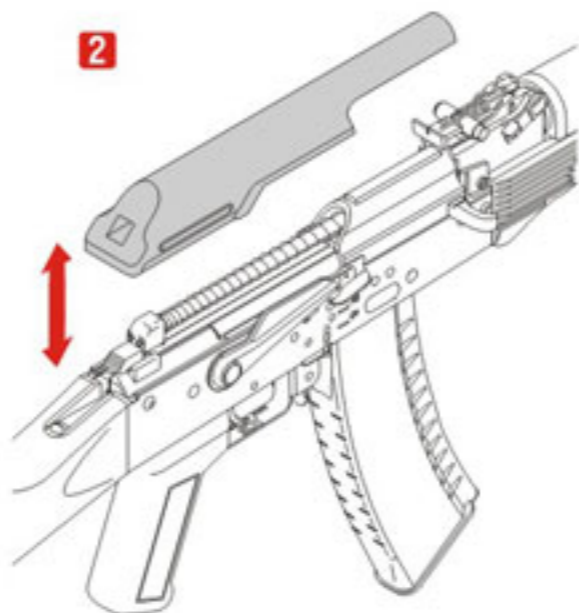

2

卸下機匣蓋。
Remove the top receiver.

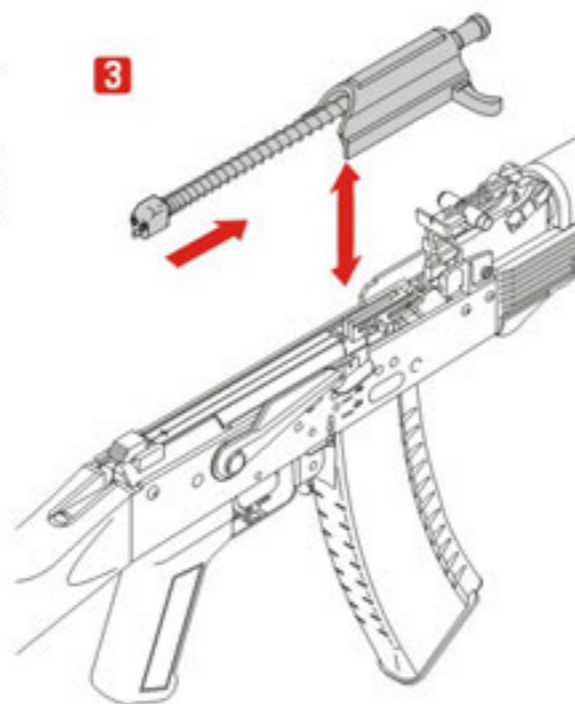

3

卸下槍機拉柄。
move the spring guide forward and pull up the spring set

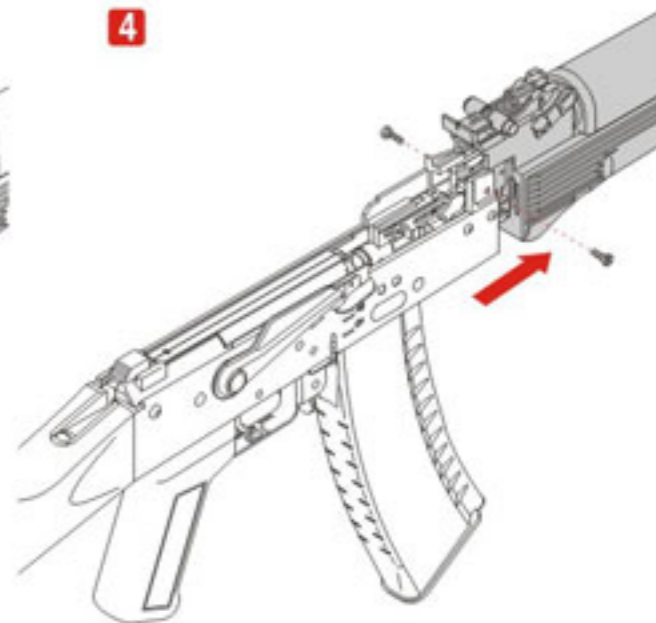

4

旋開槍管座螺絲，將視孔座往前推。
Loosen two screws from the front barrel set and push forwards to disassemble the front set.

5

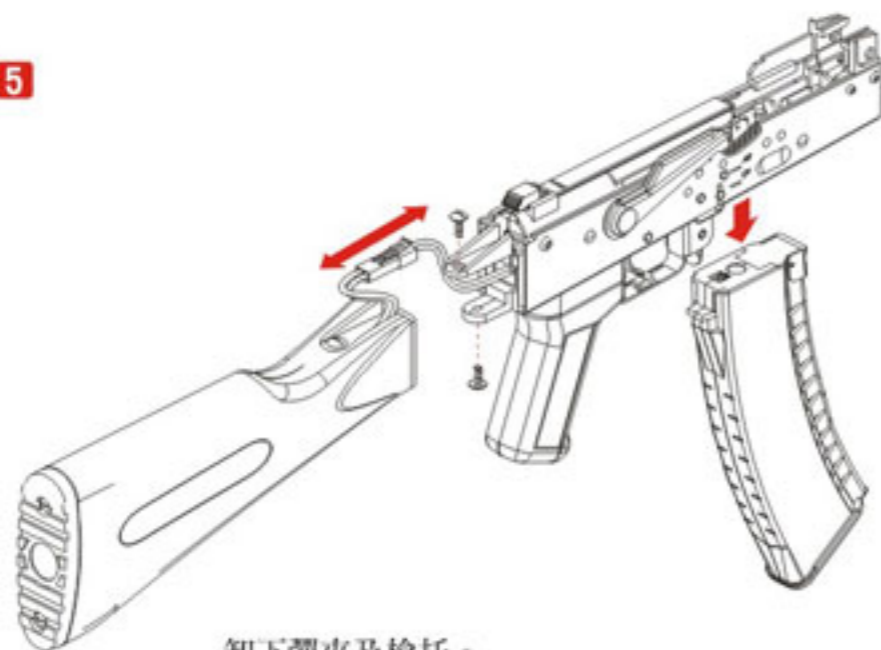

卸下彈夾及槍托。
Remove the magazine and butt stock

6

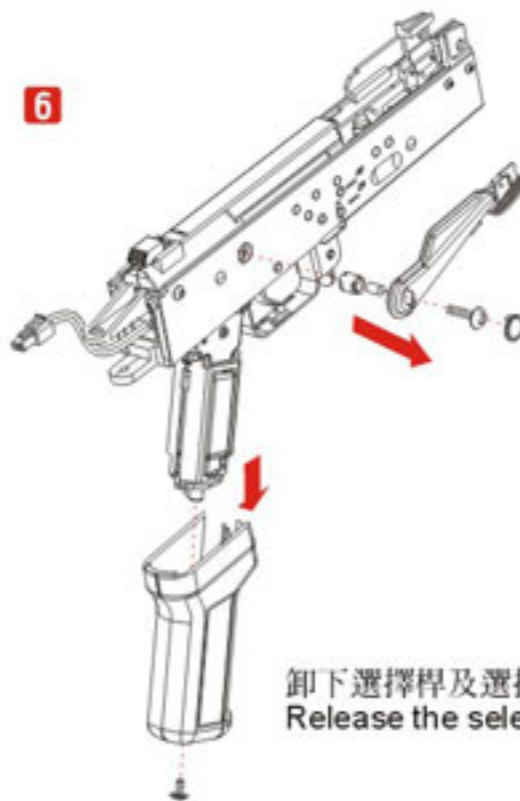

卸下選擇桿及選擇桿連動軸套握把等零件，即可將 Box 取出。
Release the selector set and fore grip than gearbox can draw out.

7

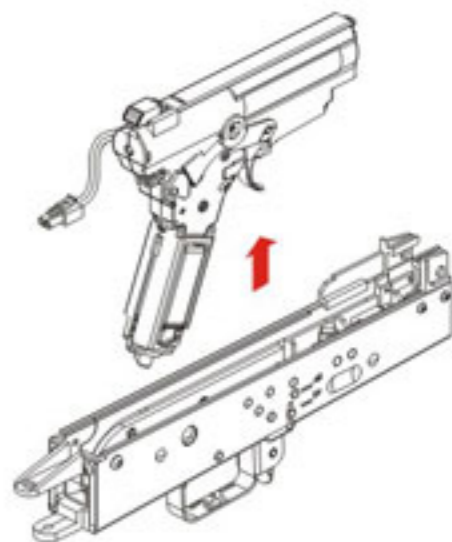

槍身與 Box 組裝

How to fabricate the receiver and box

1

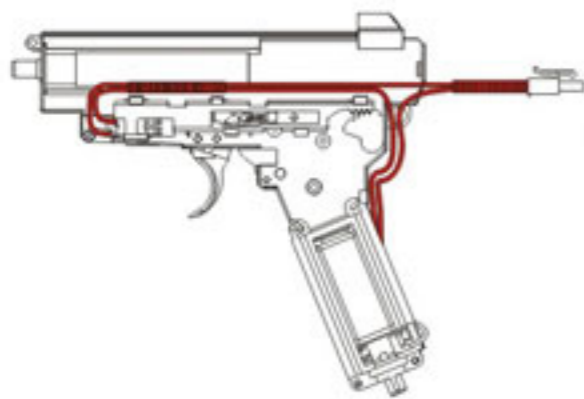

請將電線依圖示做好整理
Arrange the wires as pictured
above.

2



請注意配合位置
note the position

裝入時請注意齒片配合位置
note the gear wheel position
while assembling

將Y型連動片及保險旋片依圖示裝入
Assemble Y slice and selector slice as
illustrated.

3

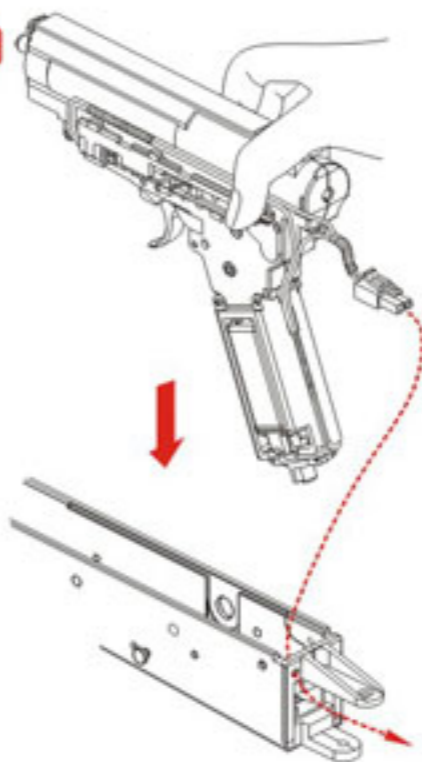

將BOX裝入槍身
Insert the gearbox into the
receiver set

4

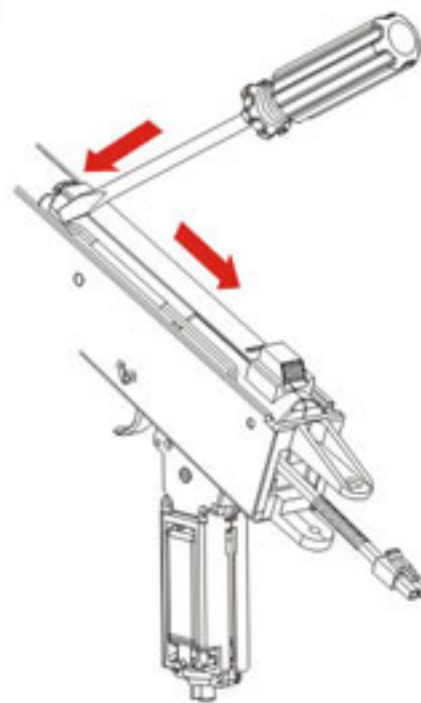

請用一字起子將電線壓入槍身
左側之溝槽內
Use a screwdriver to arrange
the wires into the left trench
of the receiver set

通槍條使用方法

How to use a cleaning rod



將棉布剪成長約25~30mm寬約10mm
後再捲繞在通槍條上
Cut the cotton cloth length : approx 25~30mm
Width : approx:10mm and wind the cut cotton cloth

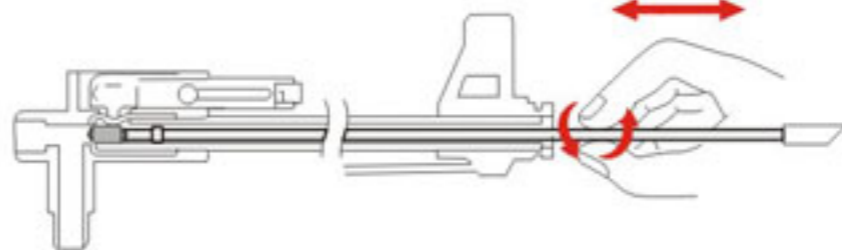
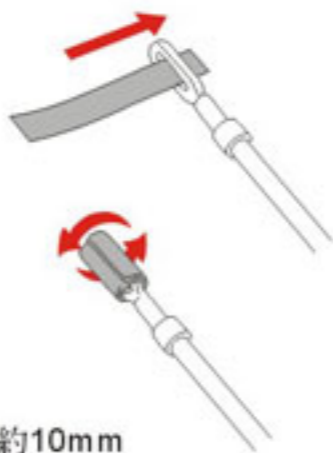

將通槍條插入並旋轉及前後拉動以清理內管
Use the cleaning rod to move the cotton
forwards and backwards along the barrel
to clean and remove any dirt build-up inside.

5



將線材拉到最佳之位置，避
免壓到線，並確認電線已裝
入BOX中。
Pull the gearbox to the right to
remove pressure on the wire.

彈匣使用方式 Magazine attachment

裝BB彈方式
Load BBs

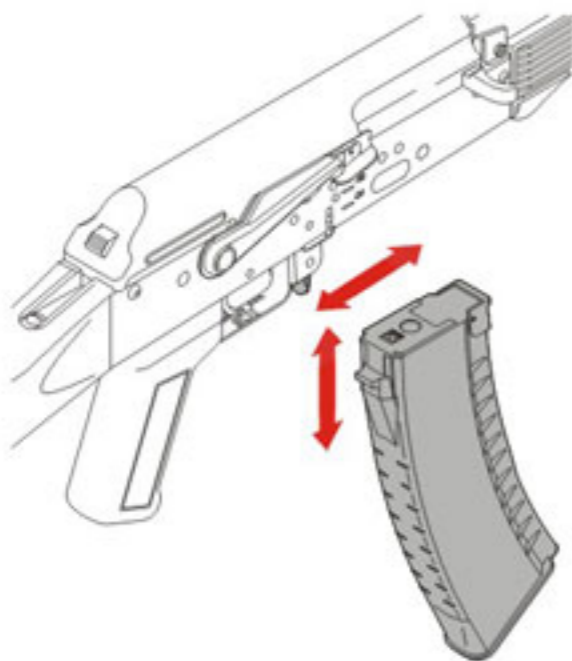

按下彈匣卡榫即可將彈匣裝入或拆下。
Press the magazine release lever to load or unload the magazine.

單連發選擇方式 Selector lever and safety setting

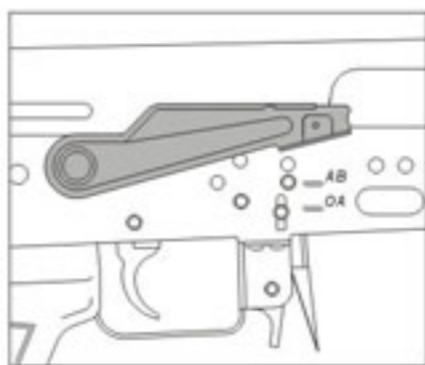

保險
Safety setting



連發
Fully automatic



單發
Semi automatic



✗ 上飄 Decrease Hop adjustment
✗ 下墜 Increase Hop adjustment
○ 正確 Best trajectory

Hop Up彈道調整 Hop Up adjustment

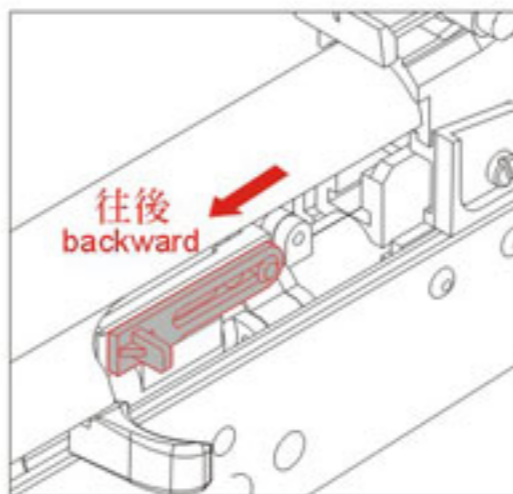
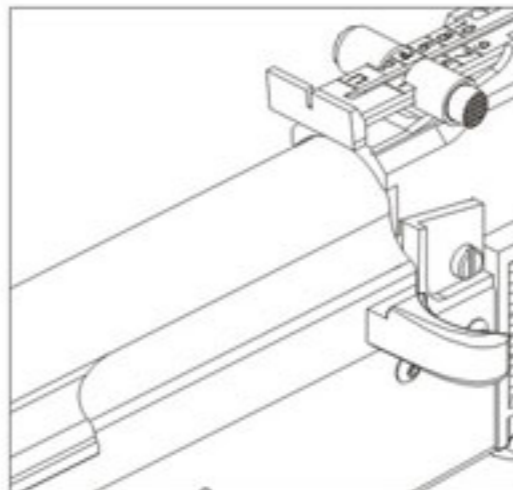

1. 上飄
Decrease Hop

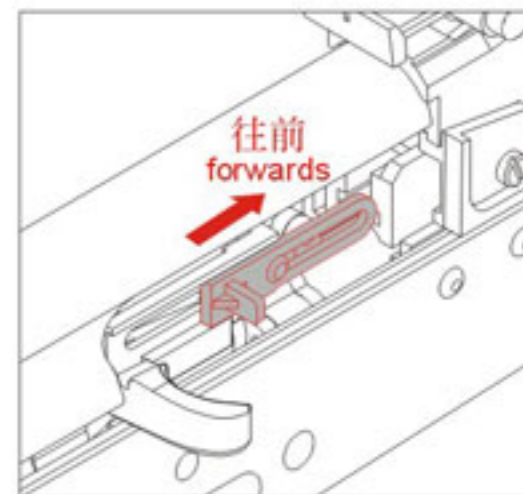

2. 下墜
Increase Hop

調整方法:

1. 將HOP UP往後調整，即可使BB彈往上飄。
2. 將HOP UP往前調整，即可使BB彈往下墜。

Adjustment procedure:

1. Backward Hop up, pellet will float up.
2. Forward Hop up, pellet will fall down.



各部零件說明
Description

