

UNIVERSITY AIRSOFT
RESERVING



ICS AIRSOFT
BE A GAME CHANGER

ICS AIRSOFT

AIRSOFT ELECTRIC GUN

中英文國際版 · INTERNATIONAL EDITION

2018

CATALOGUE

About ICS

The First Manufacture to Produce AEG In Taiwan

Everyone wants to be the winner in battlefields wherever it is in real life or just a game, and the gun in each fighter's hands plays an important role which determines who is on the winning side. The exterior of a gun is obvious: receivers, sights, and barrels. However, the inside of an ICS AEG is a symphony composed by more than 400 parts that go through around 20 types of precision machinery processes by our uncompromised team works. The inner beauty of the ICS AEG is our passion, efforts, and spirit.

When ICS founder and CEO Mr. Chu entered the airsoft replica market in 1995, ICS was the first AEG company specializing in designing and manufacturing in Taiwan. As a professional AEG brand, "highly innovative, highly efficient, and high quality" is the principle of our enterprise, and we insist upon eliminating defective part from the factories, making no mistake on the production line, and releasing no defective product to the market. In 2014, ICS received certificate of quality ISO 9001.

Thus, ICS is not only successfully earning the acknowledgment from our customers around the world, but also leading the AEG industry of Taiwan to enter the global market.

To outstand from the competitors, ICS has a strong R&D team which consists of professionals from 16 different industries. We constantly devote efforts into product design while obtaining patents for our designs and authorizations from firearm companies to provide excellent user's experiences, and to ensure the satisfaction from our customers. This is the mission of ICS: "Innovation, Competition, and Satisfaction."

ICS, The Best Thing We Create.

ICS Precision Workmanship

ICS invests in high precision CNC machines in order to produce high quality metal components such as receivers, RAS/RIS handguard, tactical rails and gearbox. All CNC machining components provide extremely realistic appearances as the real firearms. Even military standard 7075 aluminum can be processed for OEM customers.



BE A GAME CHANGER
ICS AIRSOFT

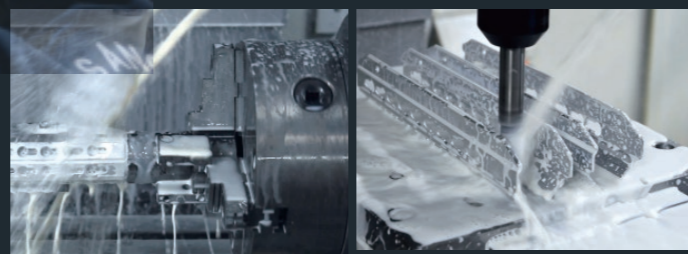

ICS Exclusive Realistic Design

1. QD Receiver & Split Gearbox

快拆槍身及分離式齒輪箱

The ICS quick disassembling receivers and the split gearbox simulate real firearms, which enable an easier access to upgrade, battlefield maintain, and trouble shooting.



2. Ergonomic Design

人體工學設計

Human engineering designed parts, such as NM4 pistol grip and MTR stock, are easy to use, providing more comfort for long patrol mission, and more grip control for intensive combat situation.



3. Advanced Upgrade Parts

高階零件升級

The upgrade parts, including MIM high torque gears, reinforced POM piston, oversized aluminum piston head, and full capacity cylinder, provide the outstanding performance for advanced players.

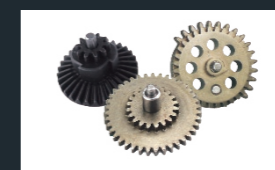
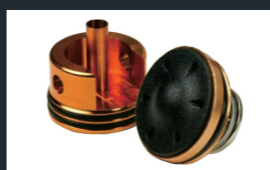

CONTENTS

SARSILMAZ SAR9	03
Korth PRS	05
BLE XFG Series	07
BLE XAE Series	09
XPD / XCP / PM2 (COMING SOON)	11
CXP Series	13
CS4 Series	51
MA Accessories	59
MAR Series	77
MK Accessories	81
WWII Series	85
ME Accessories	87
MY Accessories	90
L85/L86 Series	91
ML Accessories	95
AAR Series	97
MH Accessories	99
CES Series	101
MP Accessories	103
MGL Series	111
MM Accessories	115
TOD Series	117
MG Accessories	121
Compatible Parts	123
Original Accessories	130
Product Info	134

SARSILMAZ®



Sarsilmaz is a leading privately owned company in Turkey that possesses the capabilities required for producing guns that meet Turkish military, law enforcement, and civil use standards. Moreover, Sarsilmaz takes great pride from being the sole official pistol supplier for the Turkish National Police and the Turkish Armed Forces.

SAR9

SARSILMAZ

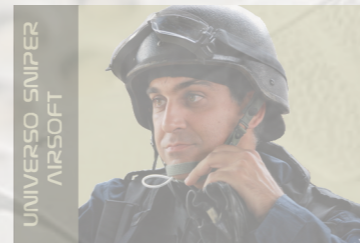

Fully licensed by Sarsilmaz Silah San. A.S., the SAR9 is a high quality pistol built by ICS in accordance to the philosophy of "Producing the Best of the Pistols". It is a lightweight, new-generation polymer construction pistol.

SARSILMAZ® The logo of SARSILMAZ® is registered trademarks of Sarsilmaz Silah San. A.S., Turkey -www.sarsilmaz.com - and is used for airsoft replicas under worldwide exclusive license.

Korth®

Korth®

"IT HAS ALWAYS BEEN SOMETHING VERY SPECIAL TO OWN A KORTH."

*Because every Korth is unique.
It used to be and still is today.*

Half a century after Willi Korth presented his very first revolver to the public, the factory Korth runs at full speed again.

The name Korth stands for unique gunsmithing. The revolvers, which we manufacture don't just shoot extreme precisely. Their appearance makes these weapons small art works that redound the glory of any man. The exquisite and individual products are valued as gifts to express highest recognition and find their way into the exclusive collections of passionate weapon collectors. The spirit of Will Korth to continuously improve even the very good things, you can feel in each weapon made by PTW KORTH Technologies GmbH. The best of steels, hand chosen timber and perfect mechanics are the ingredients, which are formed through experience, countless hours of hand working. Anyone, who has ever held a Korth in his Hand and felt its perfect balance, smooth operation and excellent timing, understands the phenomenon Korth. The shooting results speak for themselves and are the confirmation of this spirit and passion. A Korth is a piece of exclusivity. Exclusivity that arises solely from the personal drive of their master Willi Korth ...

... to build the best revolver in the world!

PRS

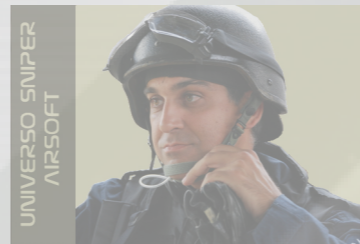
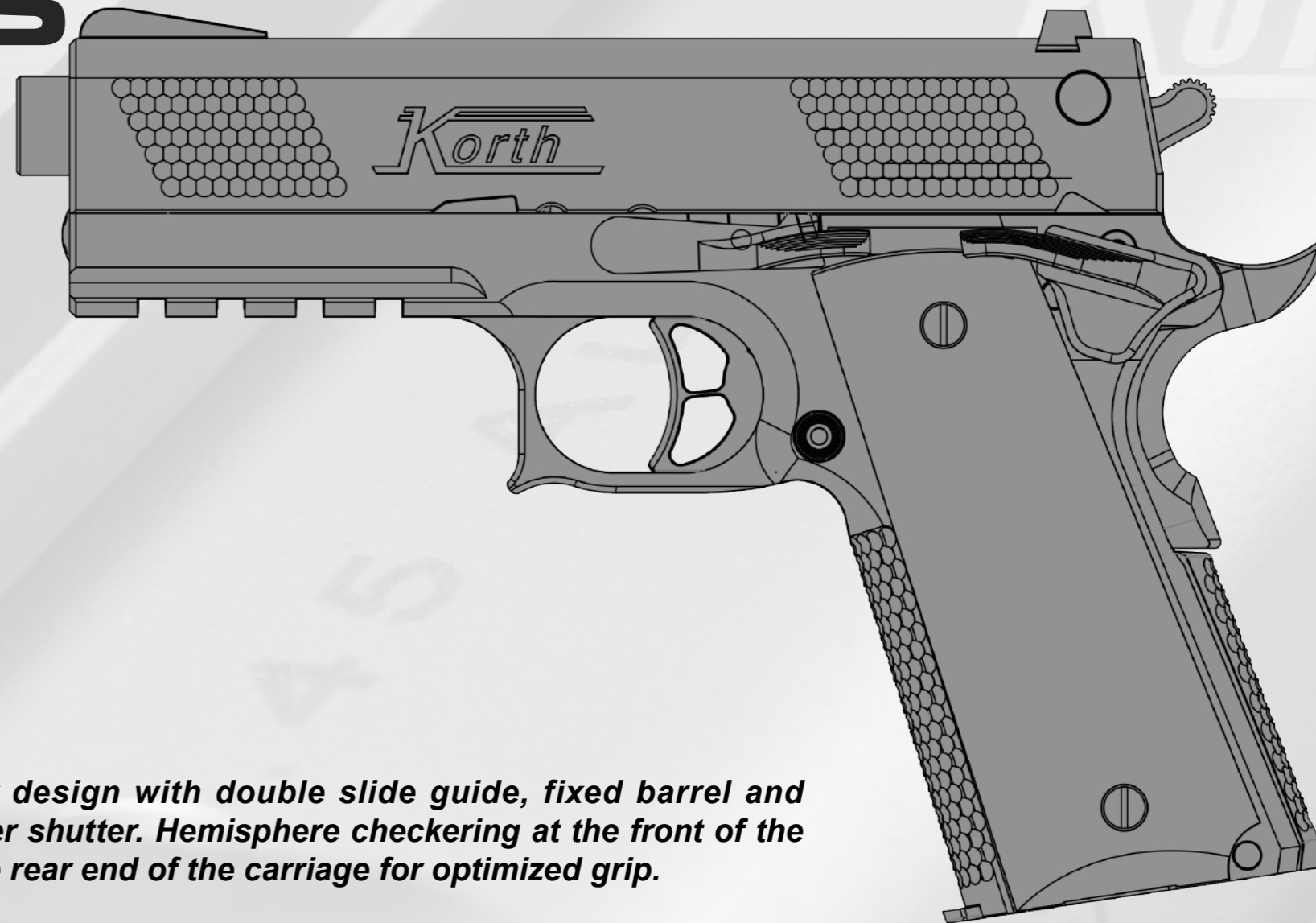

Grip in 1911er design with double slide guide, fixed barrel and semi-rigid roller shutter. Hemisphere checkering at the front of the grip, and at the rear end of the carriage for optimized grip.

Korth®



PTW KORTH Technologies GmbH, Germany, and the KORTH logo are registered trademarks of PTW KORTH Technologies GmbH, Germany - <http://www.kortharms.com> - and are used for airsoft replicas under worldwide exclusive license from Begadi GmbH - www.begadi.com.

BLE-XFG



BLE-XFG All-purpose Pistol
Newly Developed GBB Pistol by ICS.
 As its predecessor, it's designed to be ambidextrous, with a new design of engraving and texture, and luminous aiming sights, It'll provide you a brand new shooting experience.

Patent Acquired: D183252 / 003492040-0001



BLE-XFG



NEW BLE-005-ST
 BLE XFG Tan / 沙色版



NEW BLE-005-SB
 BLE XFG Black / 黑色版



NEW BLE-005-SH
 BLE XFG Hairline / 金屬髮絲紋版



NEW BLE-005-SD1
 BLE XFG Two-Tone BKTN / 雙色版



NEW BLE-005-SD2
 BLE XFG Two-Tone TNBK / 雙色版



BLE-005

Length	184mm
Barrel length	93mm
Weight	642g
Velocity	90m/s(295FPS)
Caliber	6mm
Magazine capacity	19+1 rounds
Frame material	Nylon-Reinforced Polymer
Slide material	Aluminum
Shooting mode	Semi-Automatic / Safety

※ NOTE:
 1. The product specification is for reference only and may be subject to change.
 4. Muzzle velocity is measured with 0.20g BB's, and is adjusted to comply with market regulation/ requirements for specific countries as shown below:
 Below 106 m/s (350 FPS): Belgium, France, Netherlands, Portugal, Spain, UK
 Below 100 m/s (328 FPS): Italy
 Below 95 m/s (312 FPS): Japan
 Below 45 m/s (148 FPS): Korea

BLE-XAE

Xtreme Ambi Enhanced Pistol



*The Incredible BLE-XAE.
The innovative and advanced XAE follows
the standards set by ICS rifles to bring you a high
quality, high performance pistol.
The XAE features ambidextrous slide catch and ambidextrous magazine catch,
thus being ideal for both right and left-handed shooters.*



Patent Acquired: 003765049-0001



BLE-XAE



NEW BLE-006-SD4
BLE XAE Two-Tone TNBK / 雙色版



NEW BLE-006-SB
BLE XAE Black / 黑色版



NEW BLE-006-SD3
BLE XAE Two-Tone BKTN / 雙色版



NEW BLE-006-ST
BLE XAE Tan / 沙色版



TAIWAN EXCELLENCE 2018

■ BLE-006

Length	184mm
Barrel length	85mm
Weight	670g
Velocity	90m/s(295FPS)
Caliber	6mm
Magazine capacity	24 rounds
Frame material	Nylon-Reinforced Polymer
Slide material	Aluminum
Shooting mode	Semi-Automatic / Safety

※ NOTE:

1. The product specification is for reference only and may be subject to change.
2. Muzzle velocity is measured with 0.20g BB's, and is adjusted to comply with market regulation/requirements for specific countries as shown below:
 Below 106 m/s (350 FPS): Belgium, France, Netherlands, Portugal, Spain, UK
 Below 100 m/s (328 FPS): Italy
 Below 95 m/s (312 FPS): Japan
 Below 45 m/s (148 FPS): Korea

COMING SOON



XPD

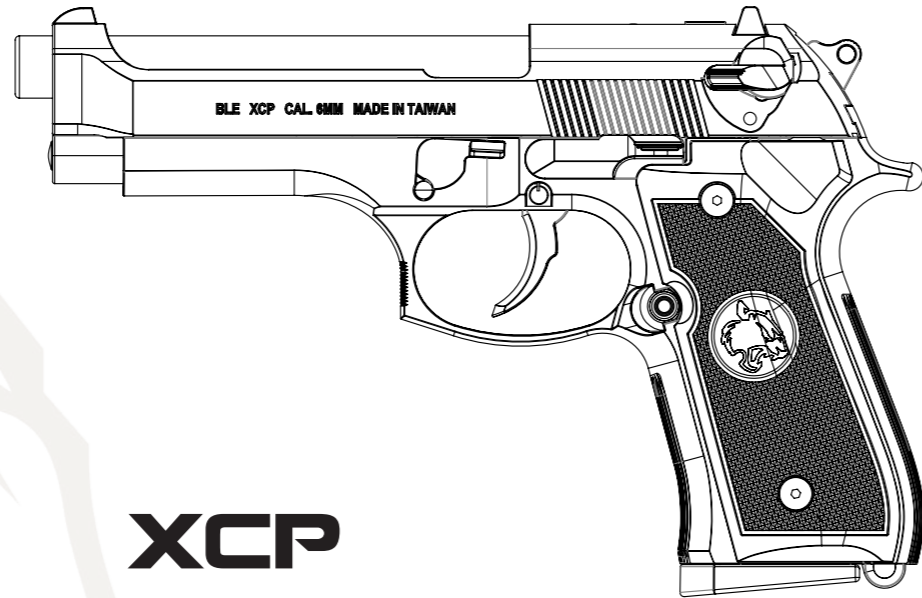

XCP

Patent Acquired: 003352756-0001 / D182159



PM2 MAKAROV
HIGH POWER AIRSOFT PISTOL



COMING SOON

ICS BE A GAME CHANGER
ICS AIRSOFT

M-LOK

In 2007, Magpul introduced the first negative space attachment system for firearms with what became the MOE slot system.

No longer was it necessary to use a Picatinny rail as an intermediate, and accessories could be direct-mounted to hand guards and other surfaces.

Fast forward a few years. Other direct attachment systems came to market where access to the backside of the mounting surface was no longer needed...an improvement in usability.

After shaker table testing, thousands upon thousands of rounds of live fire testing, drop testing, pullout testing, and manufacturing time and material studies, Magpul developed and moved forward with the M-LOK slot system as a better solution in every metric studied.

M-LOK is stronger, easier and faster to machine, has no sharp corners, has full four way recoil lug support, is adjustable in small increments for position, is repeatable, and is generally considered visually appealing.

Now ICS has been officially authorized by Magpul to use M-LOK standard, allowing us to provide more reliable products for the future of the airsoft industry.



CXP-MMR



NEW IMT-401-1 CXP-MMR Carbine TAN Proline
MTR S1 Stock / MTR S1 戰術伸縮托 金屬版

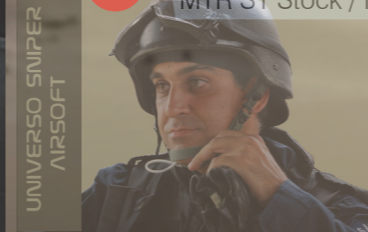

NEW ICS-400 CXP-MMR DMR Proline
UKSR Stock / UKSR 狙擊托 金屬版



CXP-MMR



NEW ICS-400 CXP-MMR DMR Proline
UKSR Stock / UKSR 狙擊托 金屬版



NEW ICS-401 CXP-MMR Carbine Proline
MTR S1 Stock / MTR S1 戰術伸縮托 金屬版



NEW ICS-402 CXP-MMR SBR Proline
MTR Stock / MTR 戰術伸縮托 金屬版

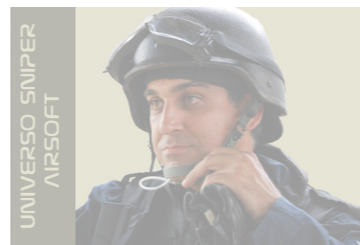

CXP-MMR



NEW IMT-400-1 CXP-MMR DMR TAN Proline
UKSR Stock / UKSR 狙擊托 金屬版



NEW IMT-401-1 CXP-MMR Carbine TAN Proline
MTR S1 Stock / MTR S1 戰術伸縮托 金屬版



NEW IMT-402-1 CXP-MMR SBR TAN Proline
MTR Stock / MTR 戰術伸縮托 金屬版



	ICS-400 IMT-400-1	ICS-401 IMT-401-1	ICS-402 IMT-402-1
Length/Retractable	975/1003 (mm)	835/930 (mm)	725/800 (mm)
Barrel length (mm)	458	375	263
Muzzle velocity	120 m/s (395fps) ※	120 m/s (395fps) ※	120 m/s (395fps) ※
Weight (g)	3393	2886	2678
Battery type	9.6V Ni-Mh or 11.1V Li-Po	9.6V Ni-Mh or 11.1V Li-Po	9.6V Ni-Mh or 11.1V Li-Po
Connector size	Small connector	Small connector	Small connector
Mag. capacity	300	300	300
Spring	M120	M120	M120
Material	Full metal	Full metal	Full metal
Motor axle	Long	Long	Long

※ NOTE:
1. The product specification is for reference only and may be subject to change.
2. Battery type is recommended, not included.
3. For AEG with M100 spring, it is recommended to use voltage 7.4V Li-Po or 9.6V Ni-Mh batteries.
4. Muzzle velocity is measured with 0.20g BB's, and is adjusted to comply with market regulation/requirements for specific countries as shown below:
Below 106 m/s (350 FPS): Belgium, France, Netherlands, Portugal, Spain, UK
Below 100 m/s (328 FPS): Italy
Below 95 m/s (312 FPS): Japan
Below 45 m/s (148 FPS): Korea

CXP-YAK



NEW IMT-412-1 CXP-YAK R SR Tan Proline
UKSR Stock / UKSR 狙擊托 金屬版

NEW ICS-412 CXP-YAK R SR Proline
UKSR Stock / UKSR 狙擊托 金屬版

ICS-410
IMT-410-1

ICS-411
IMT-411-1

ICS-412
IMT-412-1

ICS-413
IMT-413-1

Length/Retractable	825/733 (mm)	930/835(mm)	947/975(mm)	838/743 (mm)
Barrel length (mm)	263	375	420	263
Muzzle velocity	120 m/s (395fps) ※	120 m/s (395fps) ※	120 m/s (395fps) ※	120 m/s (395fps) ※
Weight (g)	3067	3145	3617	3145
Battery type	9.6V Ni-Mh or 11.1V Li-Po	9.6V Ni-Mh or 11.1V Li-Po	9.6V Ni-Mh or 11.1V Li-Po	9.6V Ni-Mh or 11.1V Li-Po
Connector size	Small connector	Small connector	Small connector	Small connector
Mag. capacity	300	300	300	300
Spring	M120	M120	M120	M120
Material	Full metal	Full metal	Full metal	Full metal
Motor axle	Long	Long	Long	Long

※ NOTE:
1. The product specification is for reference only and may be subject to change.
2. Battery type is recommended, not included.
3. For AEG with M100 spring, it is recommended to use voltage 7.4V Li-Po or 9.6V Ni-Mh batteries.
4. Muzzle velocity is measured with 0.20g BB's, and is adjusted to comply with market regulation/requirements for specific countries as shown below:
Below 106 m/s (350 FPS): Belgium, France, Netherlands, Portugal, Spain, UK
Below 100 m/s (328 FPS): Italy
Below 95 m/s (312 FPS): Japan
Below 45 m/s (148 FPS): Korea

CXP-YAK



NEW IMT-410-1 CXP-YAK C S1 Tan Proline
MTR S1 Stock / MTR S1 戰術伸縮托 金屬版

NEW ICS-410 CXP-YAK C S1 Proline
MTR S1 Stock / MTR S1 戰術伸縮托 金屬版

NEW IMT-411-1 CXP-YAK S1 Tan Proline
MTR S1 Stock / MTR S1 戰術伸縮托 金屬版

NEW ICS-411 CXP-YAK S1 Proline
MTR S1 Stock / MTR S1 戰術伸縮托 金屬版

NEW IMT-413-1 CXP-YAK CQB Tan Proline
MTR S1 Stock / MTR S1 戰術伸縮托 金屬版

NEW ICS-413 CXP-YAK CQB Proline
MTR S1 Stock / MTR S1 戰術伸縮托 金屬版

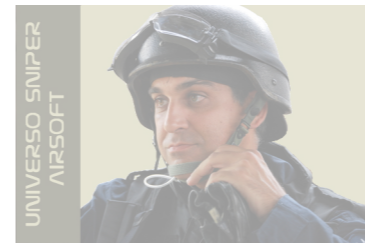

UNIVERSO SNIPER
AIRSOFT

SSS

SELF-DIAGNOSTIC SHOOTING SYSTEM

SSS 電子扳機系統

Patent Acquired: M549335 

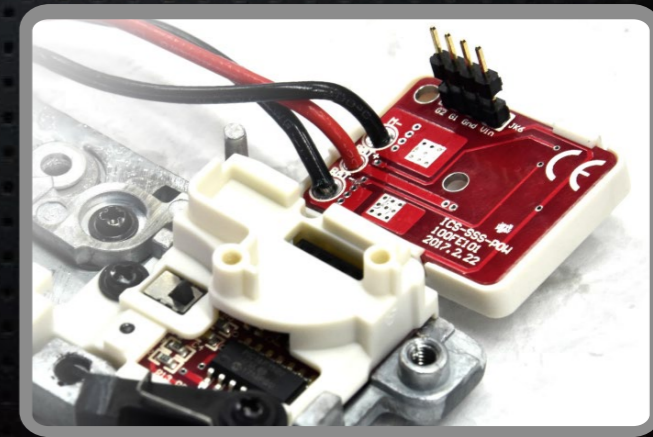
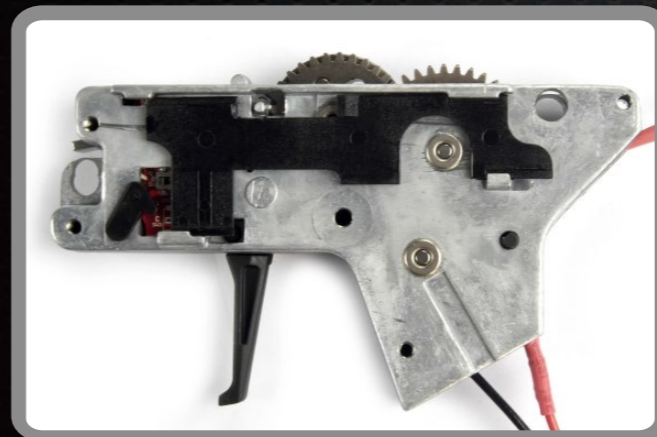
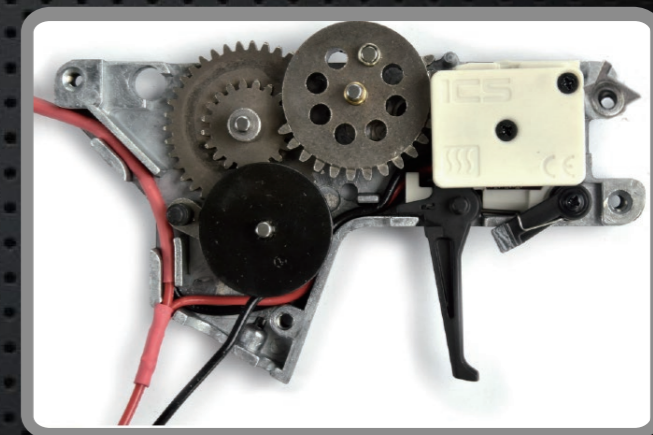
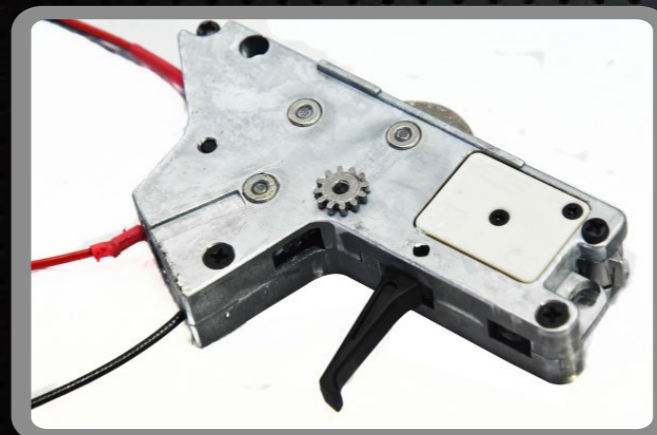
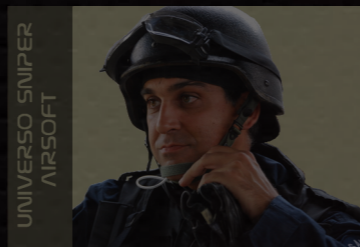

更好的相容性 齒輪箱升級不受限
Gearbox Highly Compatible
to Aftermarket Upgrade Parts

ICS 架構只要有此凸輪的市售齒輪皆可相容
DUAL Mosfet System - Power & Monitor

ICS 架構雙 FET 監控，一短路立刻斷電避免燒毀
It protects the system and prevents automatic
firing caused by short circuits.

更精簡的設計 電池空間不浪費

More Efficient MOSFET Design Without Wasting Battery Space

ICS 電子扳機系統採雙片式晶片設計，安裝位置與一般市面上將晶片安裝在托桿內的方式不同。獨家安裝於 BOX 內不另佔用電池空間，更能有效保護電池與電線免受擠壓破損，提升使用壽命。

ICS SSS Electronic Trigger System combines the FET power board and the controller board into one assembly and then replaces the switch assembly. Therefore, it can still keep the original battery room without occupying any space in the stock tube or stock.



ICSCXP

CXP M.A.R.S

ONE SYSTEM ALL SITUATION

An entirely new rifle platform and complete weapon system, engineered to be customizable, adaptable, and reliable.



Patents acquired: US 7,077,117 B1 / US D706,879 S / US D706,880 S / R.O.C. M244431 / R.O.C. M320468 / R.O.C. D160112 / R.O.C. D159178 / R.O.C. M480664 / EM002246579-0001 / R.O.C.D168410 / R.O.C.D1531145 / USD744048S / EM002541334-0001 / R.O.C. D180133 / EM003297555-0001 / EM003297530-0001/EM003568161-0001/EM003568161-0002/R.O.C. D182341



Photography by O20 magazine



CXP-MARS SERIES KOMODO



*** 2 VERSIONS AVAILABLE ***
Electronic Trigger
Self-diagnostic Shooting System 
Integrated MOSFET
HyperEfficient Durable Safe 



ICS Split Gearbox



EBB System



MTR-S1 Stock



Lightweight Keymod Handguard

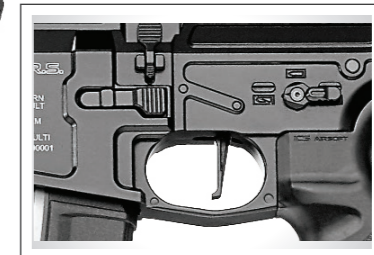
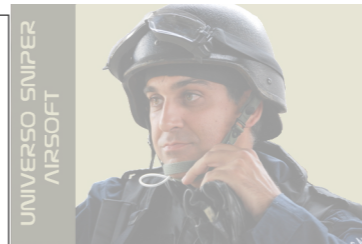

Spring Release Function



Ambidextrous Charging Handle

CXP-MARS SERIES KOMODO



NEW ICS-300 CXP-MARS Komodo Proline
MTR S1 Stock / MTR S1 戰術伸縮托 金屬版

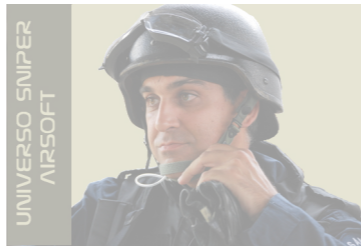

	ICS-300	ICS-300S3
Length/Retractable	935/840 (mm)	935/840 (mm)
Barrel length (mm)	375	375
Muzzle velocity	128-134 m/s (421-441 FPS) ※	128-134 m/s (421-441 FPS) ※
Weight (g)	3160	3160
Battery type	7.4V Ni-Mh or 11.1V Li-Po	7.4V or 11.1V Li-Po
Connector size	Small connector	Small connector
Mag. capacity	300	300
Spring	M120	M120
Material	Full metal	Full metal
Motor axle	Long	Long

※ NOTE:
 1. The product specification is for reference only and may be subject to change.
 2. Battery type is recommended, not included.
 3. For AEG with M100 spring, it is recommended to use voltage 7.4V Li-Po or 9.6V Ni-Mh batteries.
 4. Muzzle velocity is measured with 0.20g BB's, and is adjusted to comply with market regulation/requirements for specific countries as shown below:
 Below 106 m/s (350 FPS): Belgium, France, Netherlands, Portugal, Spain, UK
 Below 100 m/s (328 FPS): Italy
 Below 95 m/s (312 FPS): Japan
 Below 45 m/s (148 FPS): Korea



NEW IMT-300-1 CXP-MARS Komodo Proline
MTR S1 Stock / MTR S1 戰術伸縮托 金屬版



NEW IMD-300-1 CXP-MARS Komodo Proline
MTR S1 Stock / MTR S1 戰術伸縮托 金屬版

CXP-MARS SERIES SBR



NEW ICS-301 CXP-MARS SBR Proline
MTR Stock / MTR 戰術伸縮托 金屬版



NEW IMT-301-1 CXP-MARS SBR Proline
MTR Stock / MTR 戰術伸縮托 金屬版



NEW IMD-301-1 CXP-MARS SBR Proline
MTR Stock / MTR 戰術伸縮托 金屬版

	ICS-301	ICS-301S3
Length/Retractable	800/705 (mm)	800/705 (mm)
Barrel length (mm)	263	263
Muzzle velocity	125-129 m/s (411-424 FPS) ※	125-129 m/s (411-424 FPS) ※
Weight (g)	2940	2940
Battery type	7.4V Ni-Mh or 11.1V Li-Po	7.4V or 11.1V Li-Po
Connector size	Small connector	Small connector
Mag. capacity	300	300
Spring	M120	M120
Material	Full metal	Full metal
Motor axle	Long	Long

※ NOTE:
 1. The product specification is for reference only and may be subject to change.
 2. Battery type is recommended, not included.
 3. For AEG with M100 spring, it is recommended to use voltage 7.4V Li-Po or 9.6V Ni-Mh batteries.
 4. Muzzle velocity is measured with 0.20g BB's, and is adjusted to comply with market regulation/requirements for specific countries as shown below:
 Below 106 m/s (350 FPS): Belgium, France, Netherlands, Portugal, Spain, UK
 Below 100 m/s (328 FPS): Italy
 Below 95 m/s (312 FPS): Japan
 Below 45 m/s (148 FPS): Korea

CXP-MARS SERIES CARBINE

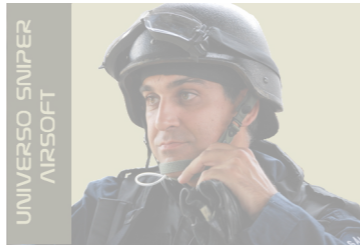

NEW ICS-302 CXP-MARS SBR Proline
MTR Stock / MTR 戰術伸縮托 金屬版



NEW IMT-302-1 CXP-MARS SBR Proline
MTR Stock / MTR 戰術伸縮托 金屬版



NEW IMD-302-1 CXP-MARS SBR Proline
MTR Stock / MTR 戰術伸縮托 金屬版

	ICS-302	ICS-302S3
	IMT-302-1	IMT-302S3-1
	IMD-302-1	IMD-302S3-1
Length/Retractable	905/810 (mm)	905/810 (mm)
Barrel length (mm)	375	375
Muzzle velocity	128-134 m/s (421-441 FPS) ※	128-134 m/s (421-441 FPS) ※
Weight (g)	3040	3040
Battery type	7.4V Ni-Mh or 11.1V Li-Po	7.4V or 11.1V Li-Po
Connector size	Small connector	Small connector
Mag. capacity	300	300
Spring	M120	M120
Material	Full metal	Full metal
Motor axle	Long	Long

※ NOTE:
 1. The product specification is for reference only and may be subject to change.
 2. Battery type is recommended, not included.
 3. For AEG with M100 spring, it is recommended to use voltage 7.4V Li-Po or 9.6V Ni-Mh batteries.
 4. Muzzle velocity is measured with 0.20g BB's, and is adjusted to comply with market regulation/requirements for specific countries as shown below:
 Below 106 m/s (350 FPS): Belgium, France, Netherlands, Portugal, Spain, UK
 Below 100 m/s (328 FPS): Italy
 Below 95 m/s (312 FPS): Japan
 Below 45 m/s (148 FPS): Korea

CXP-MARS SERIES DMR



NEW ICS-303 CXP-MARS DMR Proline
UKSR Stock / UKSR 狙擊托 金屬版



NEW IMT-303-1 CXP-MARS DMR Proline
UKSR Stock / UKSR 狙擊托 金屬版



NEW IMD-303-1 CXP-MARS DMR Proline
UKSR Stock / UKSR 狙擊托 金屬版

	ICS-303	ICS-303S3
	IMT-303-1	IMT-303S3-1
	IMD-303-1	IMD-303S3-1
Length/Retractable	980/1010 (mm)	980/1010 (mm)
Barrel length (mm)	458	458
Muzzle velocity	129-135 m/s (424-444 FPS) ※	129-135 m/s (424-444 FPS) ※
Weight (g)	3610	3610
Battery type	7.4V Ni-Mh or 11.1V Li-Po	7.4V or 11.1V Li-Po
Connector size	Small connector	Small connector
Mag. capacity	300	300
Spring	M120	M120
Material	Full metal	Full metal
Motor axle	Long	Long

※ NOTE:
 1. The product specification is for reference only and may be subject to change.
 2. Battery type is recommended, not included.
 3. For AEG with M100 spring, it is recommended to use voltage 7.4V Li-Po or 9.6V Ni-Mh batteries.
 4. Muzzle velocity is measured with 0.20g BB's, and is adjusted to comply with market regulation/requirements for specific countries as shown below:
 Below 106 m/s (350 FPS): Belgium, France, Netherlands, Portugal, Spain, UK
 Below 100 m/s (328 FPS): Italy
 Below 95 m/s (312 FPS): Japan
 Below 45 m/s (148 FPS): Korea

CXP-APE

Born for Combat with all Terrain
輕鬆掌握全地形的作戰模式

SERIES

Evolution!

ICS focuses on innovation and development to create the CXP-APE. Versatile and user-friendly rifle with simple design. Players can overcome all terrain combat easily.

The new five-position Keymod is superior to adapt for rails. The folding stock as the CXP-APE has ergonomic design, cheek rest is adjustable for height and fore/aft positions, and better stability & accuracy by rubber butt-pad. The CXP-APE will bring you a whole new experience!!

Photography by Walter Sidas of Airsoft Insider Magazine

Patents acquired: US D607,078 S / US D706,879 S / US D706,880 S / US D721,407 S / US D733,223 S / D 124836 / D 160112 / D 159178 / D 169080 / D 169081 / M 351340 / M 480664 / ZL 200730331142.7 / ZL 200820137077.3 / 002246579-0001 / 002509737-0001



* 圖片僅供參考，不包含圖示配件
* Photo for reference only. Not include the gun accessories.

CXP-APE

IMD-230-1 CXP-APE Two-Tone Proline
SF1 Stock / SF1 戰術伸縮托 金屬版



Split Gearbox



EBB System



Situation Flexible 1 Stock



Newly Designed Flash Hider

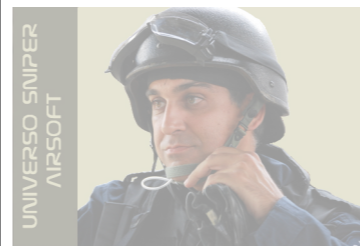

UNIVERSO SNIPER AIRSOFT



3-Way Magazine Release



Quick-Detach Barrel System



Install the Battery in SF1 Stock

CXP-APE



ICS-231 CXP-APE R Proline

SF1 Stock / SF1 戰術伸縮托 金屬版

IMD-231-1 CXP-APE R Two-Tone Proline

SF1 Stock / SF1 戰術伸縮托 金屬版

IMT-231-1 CXP-APE R Tan Proline

SF1 Stock / SF1 戰術伸縮托 金屬版

	ICS-231	IMT-231-1	IMD-231-1
Length/Retractable	895/827 (mm)	895/827 (mm)	895/827 (mm)
Barrel length (mm)	375	375	375
Muzzle velocity	114-133 m/s (374-436fps) ※	114-133 m/s (374-436fps) ※	114-133 m/s (374-436fps) ※
Weight (g)	3000	3000	3000
Battery type	9.6V Ni-Mh or 11.1V Li-Po	9.6V Ni-Mh or 11.1V Li-Po	9.6V Ni-Mh or 11.1V Li-Po
Connector size	Small connector	Small connector	Small connector
Mag. capacity	300	300	300
Spring	M120	M120	M120
Material	Full metal	Full metal	Full metal
Motor axle	Long	Long	Long

※ NOTE:

- The product specification is for reference only and may be subject to change.
- Battery type is recommended, not included.
- For AEG with M100 spring, it is recommended to use voltage 7.4V Li-Po or 9.6V Ni-Mh batteries.
- Muzzle velocity is measured with 0.20g BB's, and is adjusted to comply with market regulation/requirements for specific countries as shown below:
 Below 106 m/s (350 FPS): Belgium, France, Netherlands, Portugal, Spain, UK
 Below 100 m/s (328 FPS): Italy
 Below 95 m/s (312 FPS): Japan
 Below 45 m/s (148 FPS): Korea

CXP-APE



ICS-230 CXP-APE Proline

SF1 Stock / SF1 戰術伸縮托 金屬版

IMT-230-1 CXP-APE Tan Proline

SF1 Stock / SF1 戰術伸縮托 金屬版

	ICS-230	IMT-230-1	IMD-230-1
Length/Retractable	784/716 (mm)	784/716 (mm)	784/716 (mm)
Barrel length (mm)	263	263	263
Muzzle velocity	115-130 m/s (377-427fps) ※	115-130 m/s (377-427fps) ※	115-130 m/s (377-427fps) ※
Weight (g)	2900	2900	2900
Battery type	9.6V Ni-Mh or 11.1V Li-Po	9.6V Ni-Mh or 11.1V Li-Po	9.6V Ni-Mh or 11.1V Li-Po
Connector size	Small connector	Small connector	Small connector
Mag. capacity	300	300	300
Spring	M120	M120	M120
Material	Full metal	Full metal	Full metal
Motor axle	Long	Long	Long

※ NOTE:

- The product specification is for reference only and may be subject to change.
- Battery type is recommended, not included.
- For AEG with M100 spring, it is recommended to use voltage 7.4V Li-Po or 9.6V Ni-Mh batteries.
- Muzzle velocity is measured with 0.20g BB's, and is adjusted to comply with market regulation/requirements for specific countries as shown below:
 Below 106 m/s (350 FPS): Belgium, France, Netherlands, Portugal, Spain, UK
 Below 100 m/s (328 FPS): Italy
 Below 95 m/s (312 FPS): Japan
 Below 45 m/s (148 FPS): Korea

CXP-HOG



Photography by Team GOTAC from Chile

CXP-HOG TUBULAR

ICS-275 CXP-HOG Tubular L SR Proline

UKSR Stock / UKSR 狙擊托 金屬版



EBB System



UKSR Sniper Stock



ICS-274 ICS-275

	ICS-274	ICS-275
Length/Retractable	910/880 (mm)	925/895 (mm)
Barrel length (mm)	375	375
Muzzle velocity	123-134 m/s (404-440 FPS) ※	121-134 m/s (397-440 FPS) ※
Weight (g)	3300	3300
Battery type	9.6V Ni-Mh or 11.1V Li-Po	9.6V Ni-Mh or 11.1V Li-Po
Connector size	Small connector	Small connector
Mag. capacity	300	300
Spring	M120	M120
Material	Full metal	Full metal
Motor axle	Long	Long



※ NOTE:

- The product specification is for reference only and may be subject to change.
- Battery type is recommended, not included.
- For AEG with M100 spring, it is recommended to use voltage 7.4V Li-Po or 9.6V Ni-Mh batteries.
- Muzzle velocity is measured with 0.20g BB's, and is adjusted to comply with market regulation/requirements for specific countries as shown below:
 Below 106 m/s (350 FPS): Belgium, France, Netherlands, Portugal, Spain, UK
 Below 100 m/s (328 FPS): Italy
 Below 95 m/s (312 FPS): Japan
 Below 45 m/s (148 FPS): Korea



ICS-274 CXP-HOG Tubular SR Proline

UKSR Stock / UKSR 狙擊托 金屬版



CXP-HOG TUBULAR

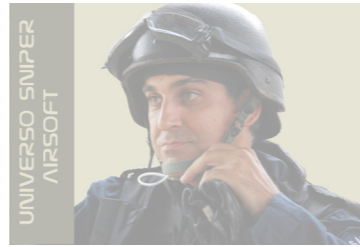

後出線版本
REAR WIRED
ICS-380 CXP-HOG Tubular SD MTR Proline
MTR Stock / MTR S1 Stock / MTR S1 戰術伸縮托



後出線版本
REAR WIRED
ICS-383 CXP-HOG Tubular SSD MTR Proline
MTR Stock / CXP-HOG 圓管護木 短版 SD MTR 托

	ICS-380	ICS-383
Length/Retractable	880/800(mm)	800/720 (mm)
Barrel length (mm)	375	303
Muzzle velocity	120-138 m/s (394-453 FPS) ※	113-130 m/s (371-427 FPS) ※
Weight (g)	2860	2690
Battery type	9.6V Ni-Mh or 11.1V Li-Po	9.6V Ni-Mh or 11.1V Li-Po
Connector size	Small connector	Small connector
Mag. capacity	300	300
Spring	M120	M120
Material	Full metal	Full metal
Motor axle	Long	Long

※ NOTE:

- The product specification is for reference only and may be subject to change.
- Battery type is recommended, not included.
- For AEG with M100 spring, it is recommended to use voltage 7.4V Li-Po or 9.6V Ni-Mh batteries.
- Muzzle velocity is measured with 0.20g BB's, and is adjusted to comply with market regulation/requirements for specific countries as shown below:
Below 106 m/s (350 FPS): Belgium, France, Netherlands, Portugal, Spain, UK
Below 100 m/s (328 FPS): Italy
Below 95 m/s (312 FPS): Japan
Below 45 m/s (148 FPS): Korea



CXP-HOG TUBULAR



後出線版本
REAR WIRED
ICS-381 CXP-HOG Tubular SD S1 Proline
MTR S1 Stock / MTR S1 戰術伸縮托



後出線版本
REAR WIRED
ICS-382 CXP-HOG Tubular SD SR Proline
UKSR Stock / UKSR 狙擊托 金屬版

	ICS-381	ICS-382
Length/Retractable	900/810 (mm)	910/880 (mm)
Barrel length (mm)	375	375
Muzzle velocity	120-138 m/s (394-453 FPS) ※	120-138 m/s (394-453 FPS) ※
Weight (g)	2920	3300
Battery type	9.6V Ni-Mh or 11.1V Li-Po	9.6V Ni-Mh or 11.1V Li-Po
Connector size	Small connector	Small connector
Mag. capacity	300	300
Spring	M120	M120
Material	Full metal	Full metal
Motor axle	Long	Long

※ NOTE:

- The product specification is for reference only and may be subject to change.
- Battery type is recommended, not included.
- For AEG with M100 spring, it is recommended to use voltage 7.4V Li-Po or 9.6V Ni-Mh batteries.
- Muzzle velocity is measured with 0.20g BB's, and is adjusted to comply with market regulation/requirements for specific countries as shown below:
Below 106 m/s (350 FPS): Belgium, France, Netherlands, Portugal, Spain, UK
Below 100 m/s (328 FPS): Italy
Below 95 m/s (312 FPS): Japan
Below 45 m/s (148 FPS): Korea



CXP-HOG QRS



前出線版本
FRONT WIRED
ICS-272 CXP-HOG QRS Proline
QRS Stock / QRS 戰術伸縮托 金屬版



前出線版本
FRONT WIRED
IMT-272-1 CXP-HOG QRS Tan Proline
QRS Stock / QRS 戰術伸縮托 金屬版

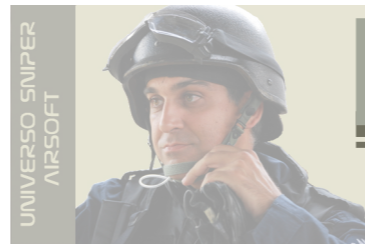

CXP-HOG MTR



前出線版本
FRONT WIRED
ICS-270 CXP-HOG Proline
MTR Stock / MTR 戰術伸縮托 金屬版

後出線版本
REAR WIRED **ICS-271 CXP-HOG** MTR Stock



前出線版本
FRONT WIRED
IMT-270-1 CXP-HOG Tan Proline
MTR Stock / MTR 戰術伸縮托 金屬版

後出線版本
REAR WIRED **IMT-271-1 CXP-HOG Tan** MTR Stock

	ICS-272	IMT-272-1
Length/Retractable	775/675 (mm)	
Barrel length (mm)	263	
Muzzle velocity	115-130 m/s (377-427 FPS) ※	
Weight (g)	3000	
Battery type	9.6V Ni-Mh or 11.1V Li-Po	
Connector size	Small connector	
Mag. capacity	300	
Spring	M120	
Material	Full metal	
Motor axle	Long	

- ※ NOTE:
- The product specification is for reference only and may be subject to change.
 - Battery type is recommended, not included.
 - For AEG with M100 spring, it is recommended to use voltage 7.4V Li-Po or 9.6V Ni-Mh batteries.
 - Muzzle velocity is measured with 0.20g BB's, and is adjusted to comply with market regulation/requirements for specific countries as shown below:
 Below 106 m/s (350 FPS): Belgium, France, Netherlands, Portugal, Spain, UK
 Below 100 m/s (328 FPS): Italy
 Below 95 m/s (312 FPS): Japan
 Below 45 m/s (148 FPS): Korea

	ICS-270	ICS-271
	IMT-270-1	IMT-271-1

Length/Retractable	795/700 (mm)	795/700 (mm)
Barrel length (mm)	263	263
Muzzle velocity	115-130 m/s (377-427 FPS) ※	115-130 m/s (377-427 FPS) ※
Weight (g)	3000	3000
Battery type	9.6V Ni-Mh or 11.1V Li-Po	9.6V Ni-Mh or 11.1V Li-Po
Connector size	Small connector	Small connector
Mag. capacity	300	300
Spring	M120	M120
Material	Full metal	Full metal
Motor axle	Long	Long

CXP-UK1 SERIES



The CXP-UK1 comes standard with an ICS POM reinforced piston, metal H-up unit and a reinforced pinion and bevel gears via MIM process. These enhancements make it one of the most durable AEGs out of the box. The receiver pins have tracks on them keeping them attached to the lower receiver when disassembling the gun. The gun also has an ambidextrous charging handle allowing both right handed and left handed shooters to be comfortable. The selector switch also releases the spring tension when moving to the safety position - another feature that will prolong the life of your gun.

Photography by Section8 Ricky

CXP-UK1



Ultra slim lightweight UK1 handguard with keymod system



MTR S1 Stock



後出線版本
REAR WIRED
ICS-268 CXP-UK1 S1 Proline
MTR S1 Stock / MTR S1 戰術伸縮托 金屬版



後出線版本
REAR WIRED
ICS-267 CXP-UK1R SR Proline
UKSR Stock / 狙擊托 金屬版

	ICS-267	ICS-268
Length/Retractable	925/895 (mm)	820/725 (mm)
Barrel length (mm)	375	263
Muzzle velocity	121-142 m/s (397-466 FPS) ※	117-135 m/s (384-443 FPS) ※
Weight (g)	3380	2800
Battery type	9.6V Ni-Mh or 11.1V Li-Po	9.6V Ni-Mh or 11.1V Li-Po
Connector size	Small connector	Small connector
Mag. capacity	300	300
Spring	M120	M120
Material	Full metal	Full metal
Motor axle	Long	Long



New EBB reinforced split gearbox



Reinforced MIM bevel and pinion gear



UKSR Sniper Stock



後出線版本
REAR WIRED
ICS-264 CXP-UK1 Proline
MTR Stock / MTR 戰術伸縮托 金屬版



TAIWAN
EXCELLENCE
2017

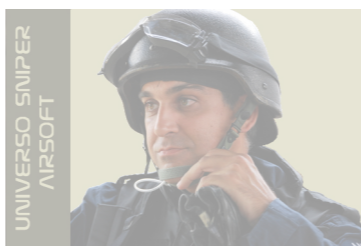

後出線版本
REAR WIRED
IMT-264-1 CXP-UK1 Proline
MTR Stock / MTR 戰術伸縮托 金屬版

	ICS-264	IMT-264-1
Length/Retractable	795/700 (mm)	
Barrel length (mm)	261	
Muzzle velocity	117-135 m/s (384-443 FPS) ※	
Weight (g)	2700	
Battery type	9.6V Ni-Mh or 11.1V Li-Po	
Connector size	Small connector	
Mag. capacity	300	
Spring	M120	
Material	Full metal	
Motor axle	Long	

- ※ NOTE:
- The product specification is for reference only and may be subject to change.
 - Battery type is recommended, not included.
 - For AEG with M100 spring, it is recommended to use voltage 7.4V Li-Po or 9.6V Ni-Mh batteries.
 - Muzzle velocity is measured with 0.20g BB's, and is adjusted to comply with market regulation/requirements for specific countries as shown below:
Below 106 m/s (350 FPS): Belgium, France, Netherlands, Portugal, Spain, UK
Below 100 m/s (328 FPS): Italy
Below 95 m/s (312 FPS): Japan
Below 45 m/s (148 FPS): Korea



ICS-264 CXP-UK1 Proline
MTR Stock / MTR 戰術伸縮托 金屬版
COMBINATION GEARBOX

IMT-264C-1 CXP-UK1 Tan Proline
MTR Stock / MTR 戰術伸縮托 金屬版
COMBINATION GEARBOX



後出線版本
REAR WIRED
IMT-265-1 CXP-UK1R Tan Proline
MTR Stock / MTR 戰術伸縮托 金屬版



後出線版本
REAR WIRED
ICS-265 CXP-UK1R Proline
MTR Stock / MTR 戰術伸縮托 金屬版

	ICS-265	ICS-264C
	IMT-265-1	IMT-264C-1
Length/Retractable	906/811 (mm)	795/700 (mm)
Barrel length (mm)	372	263
Muzzle velocity	121-142 m/s (397-466 FPS) ※	123-133 m/s (404-436 FPS) ※
Weight (g)	2920	2587
Battery type	9.6V Ni-Mh or 11.1V Li-Po	9.6V Ni-Mh or 11.1V Li-Po
Connector size	Small connector	Small connector
Mag. capacity	300	300
Spring	M120	M120
Material	Full metal	Full metal
Motor axle	Long	Long

- ※ NOTE:
- The product specification is for reference only and may be subject to change.
 - Battery type is recommended, not included.
 - For AEG with M100 spring, it is recommended to use voltage 7.4V Li-Po or 9.6V Ni-Mh batteries.
 - Muzzle velocity is measured with 0.20g BB's, and is adjusted to comply with market regulation/requirements for specific countries as shown below:
Below 106 m/s (350 FPS): Belgium, France, Netherlands, Portugal, Spain, UK
Below 100 m/s (328 FPS): Italy
Below 95 m/s (312 FPS): Japan
Below 45 m/s (148 FPS): Korea



CXP-UK1 CAPTAIN

New Full Metal Compact UK1

The UK1 Captain becomes one of the smallest UK1 variants, and inherits the UK1 series' brilliant pedigree. The free floating Keymod rail handguard is the excellent platform for mounting accessories. The overall small size is just perfect for extremely CQB situations.

UNIVERSO EMPIER AIRSOFT

Photography by Turgay Dansik

Patents acquired: D 169081 / USD 7214075 

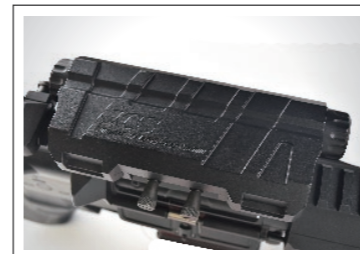

Front Wired with Battery Box



ICS EBB System



前出線版本
FRONT WIRED
IMT-263-1 CXP-UK1 Captain Tan Proline

前出線版本
FRONT WIRED
ICS-263 CXP-UK1 Captain Proline



Realistic Tube with QD Sling Swivel Mount



Ergonomic Pistol Grip



Steel Crown Flash Hider



Flip-up Front Sight

CXP-UK1 CAPTAIN

MTR STOCK



後出線版本
REAR WIRED
ICS-262 CXP-UK1 Captain MTR Proline
 MTR Stock /MTR 戰術伸縮托 金屬版



後出線版本
REAR WIRED
IMT-262-1 CXP-UK1 Captain MTR Tan Proline
 MTR Stock /MTR 戰術伸縮托 金屬版

New Full Metal Compact UK1

CXP-UK1 CAPTAIN



	ICS-263	IMT-263-1	ICS-262	IMT-262-1
Length/Retractable	512 (mm)	512 (mm)	693/617 (mm)	693/617 (mm)
Barrel length (mm)	186	186	186	186
Muzzle velocity	111-121 m/s (364-397 FPS) ※	111-121 m/s (364-397 FPS) ※	111-121 m/s (364-397 FPS) ※	111-121 m/s (364-397 FPS) ※
Weight (g)	2630	2630	2840	2840
Battery type	11.1V Li-Po	11.1V Li-Po	9.6V Ni-Mh or 11.1V Li-Po	9.6V Ni-Mh or 11.1V Li-Po
Connector size	Small connector	Small connector	Small connector	Small connector
Mag. capacity	300	300	300	300
Spring	M120	M120	M120	M120
Material	Full metal	Full metal	Full metal	Full metal
Motor axle	Long	Long	Long	Long

※ NOTE:
 1. The product specification is for reference only and may be subject to change.
 2. Battery type is recommended, not included.
 3. For AEG with M100 spring, it is recommended to use voltage 7.4V Li-Po or 9.6V Ni-Mh batteries.
 4. Muzzle velocity is measured with 0.20g BB's, and is adjusted to comply with market regulation/requirements for specific countries as shown below:
 Below 106 m/s (350 FPS): Belgium, France, Netherlands, Portugal, Spain, UK
 Below 100 m/s (328 FPS): Italy
 Below 95 m/s (312 FPS): Japan
 Below 45 m/s (148 FPS): Korea

Photography by Daniel Gordillo Vieira

CXP-15

KEYMOD SYSTEM HANDGUARD



ICS-175 CXP-15 K Proline
Crane Stock / 海豹托 金屬版



Keymod System Handguard



Split Gearbox



Spring Release Function



運動版系列
SPORTLINE ICS-174 CXP-15 K Crane Stock



	ICS-174	ICS-175
Length/Retractable	743/648 (mm)	743/648 (mm)
Barrel length (mm)	200	200
Muzzle velocity	88-103 m/s (289-338 FPS) ※	112-124 m/s (367-407 FPS) ※
Weight (g)	1900	2200
Battery type	9.6V Ni-Mh or 11.1V Li-Po	9.6V Ni-Mh or 11.1V Li-Po
Connector size	Small connector	Small connector
Mag. capacity	300	300
Spring	M100	M120
Material	Engineering plastic	Full metal
Motor axle	Long	Long

※ NOTE:

- The product specification is for reference only and may be subject to change.
- Battery type is recommended, not included.
- For AEG with M100 spring, it is recommended to use voltage 7.4V Li-Po or 9.6V Ni-Mh batteries.
- Muzzle velocity is measured with 0.20g BB's, and is adjusted to comply with market regulation/requirements for specific countries as shown below:
Below 106 m/s (350 FPS): Belgium, France, Netherlands, Portugal, Spain, UK
Below 100 m/s (328 FPS): Italy
Below 95 m/s (312 FPS): Japan
Below 45 m/s (148 FPS): Korea

ICS-171 CXP-15 K Proline
Keymod System / 金屬版



運動版系列
SPORTLINE ICS-170 CXP-15 K Keymod System



ICS-173 CXP-15 Proline
Pistol / 手槍金屬版



運動版系列
SPORTLINE ICS-172 CXP-15 Pistol / 手槍版

	ICS-170	ICS-171	ICS-172	ICS-173
Length/Retractable	732/642 (mm)	732/642 (mm)	472 (mm)	472 (mm)
Barrel length (mm)	200	200	200	200
Muzzle velocity	88-103 m/s (289-338 FPS) ※	112-124 m/s (367-407 FPS) ※	88-103 m/s (289-338 FPS) ※	112-124 m/s (367-407 FPS) ※
Weight (g)	1800	2100	1600	1900
Battery type	9.6V Ni-Mh or 7.4V Li-Po	9.6V Ni-Mh or 11.1V Li-Po	9.6V Ni-Mh or 7.4V Li-Po	9.6V Ni-Mh or 11.1V Li-Po
Connector size	Small connector	Small connector	Small connector	Small connector
Mag. capacity	300	300	300	300
Spring	M100	M120	M100	M120
Material	Engineering plastic	Full metal	Engineering plastic	Full metal
Motor axle	Long	Long	Long	Long

※ NOTE:

- The product specification is for reference only and may be subject to change.
- Battery type is recommended, not included.
- For AEG with M100 spring, it is recommended to use voltage 7.4V Li-Po or 9.6V Ni-Mh batteries.
- Muzzle velocity is measured with 0.20g BB's, and is adjusted to comply with market regulation/requirements for specific countries as shown below:
Below 106 m/s (350 FPS): Belgium, France, Netherlands, Portugal, Spain, UK
Below 100 m/s (328 FPS): Italy
Below 95 m/s (312 FPS): Japan
Below 45 m/s (148 FPS): Korea

CXP-16

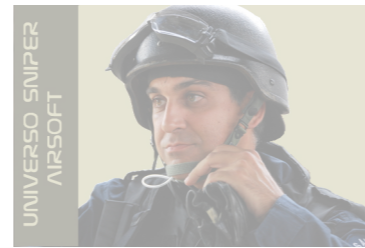

ICS-238 CXP-16 L Proline
Crane Stock / 海豹托 金屬長版



IMT-238-1 CXP-16 L Tan Proline
Crane Stock / 海豹托 金屬長版

■ ICS-238 ■ IMT-238-1

Length/Retractable	980/885 (mm)	980/885 (mm)
Barrel length (mm)	303	303
Muzzle velocity	116-136 m/s (381-446 FPS) ※	116-136 m/s (381-446 FPS) ※
Weight (g)	3300	3300
Battery type	9.6V Ni-Mh or 11.1V Li-Po	9.6V Ni-Mh or 11.1V Li-Po
Connector size	Small connector	Small connector
Mag. capacity	300	300
Spring	M120	M120
Material	Full metal	Full metal
Motor axle	Long	Long

※ NOTE:

1. The product specification is for reference only and may be subject to change.
2. Battery type is recommended, not included.
3. For AEG with M100 spring, it is recommended to use voltage 7.4V Li-Po or 9.6V Ni-Mh batteries.
4. Muzzle velocity is measured with 0.20g BB's, and is adjusted to comply with market regulation/requirements for specific countries as shown below:
Below 106 m/s (350 FPS): Belgium, France, Netherlands, Portugal, Spain, UK
Below 100 m/s (328 FPS): Italy
Below 95 m/s (312 FPS): Japan
Below 45 m/s (148 FPS): Korea



Photography by INS4NEsmilies

CXP-08



SPORTLINE
ICS-160 CXP-08 QRS Stock / 伸縮托



SPORTLINE
IPT-160-1 CXP-08 Tan QRS Stock / 伸縮托



	ICS-160 IPT-160-1	ICS-324
Length/Retractable	695/595 (mm)	695/595 (mm)
Barrel length (mm)	200	200
Muzzle velocity	90-104 m/s (295-341 FPS) ※	112-128 m/s (367-420 FPS) ※
Weight (g)	2150	2900
Battery type	9.6V Ni-Mh or 7.4V Li-Po	9.6V Ni-Mh or 11.1V Li-Po
Connector size	Small connector	Small connector
Mag. capacity	300	300
Spring	M100	M120
Material	Engineering plastic	Full metal
Motor axle	Long	Long



EBB SYSTEM
ICS-324 CXP-08 EBB QRS Stock / 伸縮托

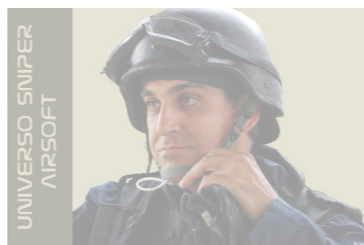

SPORTLINE
ICS-144 CXP-08 Crane Stock / 海豹托

EBB SYSTEM
ICS-325 CXP-08 EBB Crane Stock / 海豹托



	ICS-144	ICS-325
Length/Retractable	745/650 (mm)	745/650 (mm)
Barrel length (mm)	200	200
Muzzle velocity	90-104 m/s (295-341 FPS) ※	112-128 m/s (367-420 FPS) ※
Weight (g)	2300	2700
Battery type	9.6V Ni-Mh or 7.4V Li-Po	9.6V Ni-Mh or 11.1V Li-Po
Connector size	Small connector	Small connector
Mag. capacity	300	300
Spring	M100	M120
Material	Engineering plastic	Full metal
Motor axle	Long	Long

- ※ NOTE:
 1. The product specification is for reference only and may be subject to change.
 2. Battery type is recommended, not included.
 3. For AEG with M100 spring, it is recommended to use voltage 7.4V Li-Po or 9.6V Ni-Mh batteries.
 4. Muzzle velocity is measured with 0.20g BB's, and is adjusted to comply with market regulation/requirements for specific countries as shown below:
 Below 106 m/s (350 FPS): Belgium, France, Netherlands, Portugal, Spain, UK
 Below 100 m/s (328 FPS): Italy
 Below 95 m/s (312 FPS): Japan
 Below 45 m/s (148 FPS): Korea

CS4

SERIES

ICS CS4/CS16 series carries a built-in split gearbox, technology proprietary to ICS, which gives our CS4/CS16 series a more realistic disassembly experience and contributes to ease maintenance.



Photography by 野豬先鋒 from Taiwan

TUBULAR



Patents acquired: US7,077,117 B1 / US 7,971,583 B2 / US D706,880 S / US D706,879 S / ZL 200820137077.3 / 002246579-0001 / D 159178 / D 160112 / M 244431 / M 320468 / M 351340 / M 480664



Considerate Design of Adjustable Rail



Spring imported from the US



High Density Aluminium Extrusion and CNC Milling



Split Gearbox



ICS-220 CS4A1 Tubular R.A.S. L Proline
Retractable Stock / 戰術伸縮托 圓管護木金屬長版

	ICS-220	ICS-322
Length/Retractable	873/778 (mm)	873/778 (mm)
Barrel length (mm)	375	375
Muzzle velocity	115-140 m/s (377-459 FPS) ※	120-138 m/s (394-453 FPS) ※
Weight (g)	2900	3000
Battery type	11.1V Li-Po	11.1V Li-Po
Connector size	Small connector	Small connector
Mag. capacity	450	450
Spring	M120	M120
Material	Full metal	Full metal
Motor axle	Long	Long

※ NOTE:

- The product specification is for reference only and may be subject to change.
- Battery type is recommended, not included.
- For AEG with M100 spring, it is recommended to use voltage 7.4V Li-Po or 9.6V Ni-Mh batteries.
- Muzzle velocity is measured with 0.20g BB's, and is adjusted to comply with market regulation/requirements for specific countries as shown below:
Below 106 m/s (350 FPS): Belgium, France, Netherlands, Portugal, Spain, UK
Below 100 m/s (328 FPS): Italy
Below 95 m/s (312 FPS): Japan
Below 45 m/s (148 FPS): Korea



EBB SYSTEM
ICS-322 CS4A1 Tubular R.A.S. L EBB MTR Stock / MTR 戰術伸縮托

TUBULAR



ICS-221 CS4A1 Tubular R.A.S. S Proline

Retractable Stock / 戰術伸縮托 圓管護木金屬短版



	ICS-221	ICS-323
Length/Retractable	873/778 (mm)	873/778 (mm)
Barrel length (mm)	375	375
Muzzle velocity	115-140 m/s (377-459 FPS) ※	120-138 m/s (394-453 FPS) ※
Weight (g)	2850	2950
Battery type	11.1V Li-Po	11.1V Li-Po
Connector size	Small connector	Small connector
Mag. capacity	450	450
Spring	M120	M120
Material	Full metal	Full metal
Motor axle	Long	Long

※ NOTE:

- The product specification is for reference only and may be subject to change.
- Battery type is recommended, not included.
- For AEG with M100 spring, it is recommended to use voltage 7.4V Li-Po or 9.6V Ni-Mh batteries.
- Muzzle velocity is measured with 0.20g BB's, and is adjusted to comply with market regulation/requirements for specific countries as shown below:
 Below 106 m/s (350 FPS): Belgium, France, Netherlands, Portugal, Spain, UK
 Below 100 m/s (328 FPS): Italy
 Below 95 m/s (312 FPS): Japan
 Below 45 m/s (148 FPS): Korea

EBB SYSTEM

ICS-323 CS4A1 Tubular R.A.S. S EBB MTR Stock / MTR 戰術伸縮托



CS4A1



ICS-20 CS4A1 Proline

Retractable Stock / 戰術伸縮托 金屬版



EBB SYSTEM
ICS-320 CS4A1 EBB Retractable Stock / 戰術伸縮托 金屬版

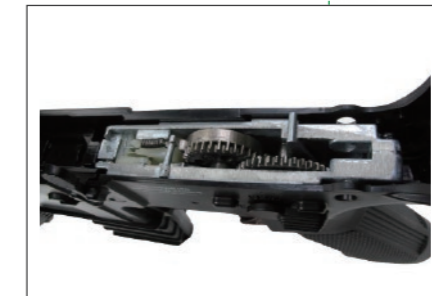

ICS Split Gearbox

	ICS-20	ICS-320
Length/Retractable	873/778 (mm)	873/778 (mm)
Barrel length (mm)	375	375
Muzzle velocity	115-140 m/s (377-459 FPS) ※	120-138 m/s (394-453 FPS) ※
Weight (g)	3000	2900
Battery type	9.6V Ni-Mh or 11.1V Li-Po	9.6V Ni-Mh or 11.1V Li-Po
Connector size	Small connector	Small connector
Mag. capacity	450	450
Spring	M120	M120
Material	Full metal	Full metal
Motor axle	Long	Long

※ NOTE:

- The product specification is for reference only and may be subject to change.
- Battery type is recommended, not included.
- For AEG with M100 spring, it is recommended to use voltage 7.4V Li-Po or 9.6V Ni-Mh batteries.
- Muzzle velocity is measured with 0.20g BB's, and is adjusted to comply with market regulation/requirements for specific countries as shown below:
 Below 106 m/s (350 FPS): Belgium, France, Netherlands, Portugal, Spain, UK
 Below 100 m/s (328 FPS): Italy
 Below 95 m/s (312 FPS): Japan
 Below 45 m/s (148 FPS): Korea

CS16A3



ICS-24 CS16A3 Proline
Fixed Stock / 固定托 金屬版



ICS-30 CS16A3 R.A.S. Proline
Fixed Stock / R.A.S. 固定托 金屬版

	ICS-24	ICS-30
Length/Retractable	1025 (mm)	1025 (mm)
Barrel length (mm)	515	515
Muzzle velocity	117-142 m/s (384-466 FPS) ※	117-142 m/s (384-466 FPS) ※
Weight (g)	3370	3750
Battery type	9.6V Ni-Mh or 11.1V Li-Po	9.6V Ni-Mh or 11.1V Li-Po
Connector size	Small connector	Small connector
Mag. capacity	450	450
Spring	M120	M120
Material	Full metal	Full metal
Motor axle	Long	Long

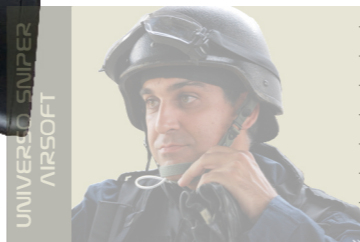

CS4 TACTICAL

戰術系列 · 突擊步槍



ICS-127 CS4 R.I.S. Proline
Crane Stock / 海豹托 金屬版

	ICS-127	ICS-321
Length/Retractable	815/730 (mm)	815/730 (mm)
Barrel length (mm)	263	263
Muzzle velocity	113-130 m/s (371-427 FPS) ※	116-132 m/s (382-433 FPS) ※
Weight (g)	3000	3250
Battery type	9.6V Ni-Mh or 11.1V Li-Po	9.6V Ni-Mh or 11.1V Li-Po
Connector size	Small connector	Small connector
Mag. capacity	450	450
Spring	M120	M120
Material	Full metal	Full metal
Motor axle	Long	Long



EBB SYSTEM
ICS-321 CS4 R.I.S. EBB Crane Stock / 海豹托 金屬版

- ※ NOTE:
- The product specification is for reference only and may be subject to change.
 - Battery type is recommended, not included.
 - For AEG with M100 spring, it is recommended to use voltage 7.4V Li-Po or 9.6V Ni-Mh batteries.
 - Muzzle velocity is measured with 0.20g BB's, and is adjusted to comply with market regulation/requirements for specific countries as shown below:
Below 106 m/s (350 FPS): Belgium, France, Netherlands, Portugal, Spain, UK
Below 100 m/s (328 FPS): Italy
Below 95 m/s (312 FPS): Japan
Below 45 m/s (148 FPS): Korea



- 運 - 動 - 版 -
- PLASTIC
VERSION -

SPORTLINE

*The same design as metal CS4.
*ICS is able to fulfill your request for the transparent / translucent plastic version of AEGs.

CS4A1



ICS-41 CS4A1 /
Retractable Stock / 戰術伸縮托



ICS-42 CS4A1 /
Fixed Stock / 固定托

R.I.S.



ICS-47 CS4 R.I.S. /
Crane Stock / 海豹托



IPT-047-1 CS4 R.I.S. Tan /
Crane Stock / 海豹托

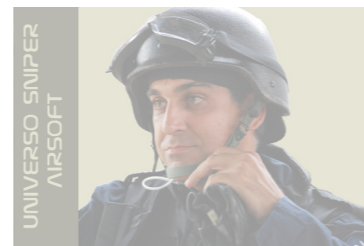

	ICS-41	ICS-42	ICS-47	IPT-047-1
Length/Retractable	873/778 (mm)	875 (mm)	815/730 (mm)	815/730 (mm)
Barrel length (mm)	375	375	263	263
Muzzle velocity	95-113 m/s (312-371 FPS) ※	95-113 m/s (312-371 FPS) ※	94-109 m/s (308-358 FPS) ※	94-109 m/s (308-358 FPS) ※
Weight (g)	2500	2700	2500	2500
Battery type	9.6V Ni-Mh or 7.4V Li-Po	9.6V Ni-Mh or 7.4V Li-Po	9.6V Ni-Mh or 7.4V Li-Po	9.6V Ni-Mh or 7.4V Li-Po
Connector size	Small connector	Small connector	Small connector	Small connector
Mag. capacity	300	300	300	300
Spring	M100	M100	M100	M100
Material	Engineering plastic	Engineering plastic	Engineering plastic	Engineering plastic
Motor axle	Long	Long	Long	Long

※NOTE:
1. The product specification is for reference only and may be subject to change.
2. Battery type is recommended, not included.
3. For AEG with M100 spring, it is recommended to use voltage 7.4V Li-Po or 9.6V Ni-Mh batteries.
4. Muzzle velocity is measured with 0.20g BB's, and is adjusted to comply with market regulation/ requirements for specific countries as shown below:
Below 106 m/s (350 FPS): Belgium, France, Netherlands, Portugal, Spain, UK
Below 100 m/s (328 FPS): Italy
Below 95 m/s (312 FPS): Japan
Below 45 m/s (148 FPS): Korea



CS4 / CXP Compatible Parts

Handguard

護木

UK1 Captain Handguard Set L152 UK1 Captain 護木組 L152

MA-354 BK 黑色

MA-355 TAN 沙色



CXP-16 Handguard L220
CXP-16 護木 L220 (短版)
MA-343 BK 黑色
MA-346 TAN 沙色

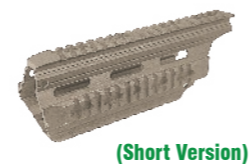

CXP-16 Handguard L318
CXP-16 護木組 L318(長版)
MA-319 BK 黑色
MA-345 TAN 沙色



HOG Handguard Set
HOG 護木組
MA-311 BK 黑色
MA-316 TAN 沙色



UK1R Handguard L320
UK1R 護木 L320
MA-224



UK1R Handguard L320-Tan
UK1R 護木 L320-沙色
MA-281



UK1 Handguard L230
UK1 護木 L230
MA-222



UK1 Handguard L230-Tan
UK1 護木 L230-沙色
MA-280

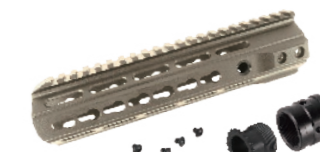

CS4A1 Handguard
CS4A1 護木
MA-06



CS16A3 Handguard
CS16A3 護木
MA-65



CXP-08 Upper Handguard
CXP-08 上護木
MA-98



CXP-08 Lower Handguard
CXP-08 下護木
MA-101



CS4 CQB R.A.S. Handguard
CS4 CQB R.A.S. 護木
MA-81

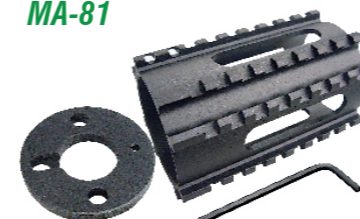

CS4 R.A.S. Handguard
CS4 R.A.S. 戰術護木
MA-73



CS16A3 R.A.S. Handguard
CS16A3 R.A.S. 護木
MA-85



R.I.S. Tactical Handguard
R.I.S. 戰術護木組
MA-58



CS4 Tubular Handguard
CS4 圓管護木 - 短
MA-183



CS4 Tubular Handguard
CS4 圓管護木 - 長
MA-184



CXP-15 Keymod Handguard
CXP-15 護木組
MA-236



APE Handguard
APE 護木組
MA-301



APE Handguard
APE 護木組 - 沙色
MA-309



NEW MMR / MARS / YAK Compatible Parts

Handguard

護木

Patent Acquired: D180133 / 003297555-0001



MARS Handguard 10"
MARS 護木 10 吋

NEW MA-402 BK 黑色



MARS Handguard 13"
MARS 護木 13 吋

NEW MA-403 BK 黑色



MARS Handguard 16"
MARS 護木組 16 吋

NEW MA-404 BK 黑色

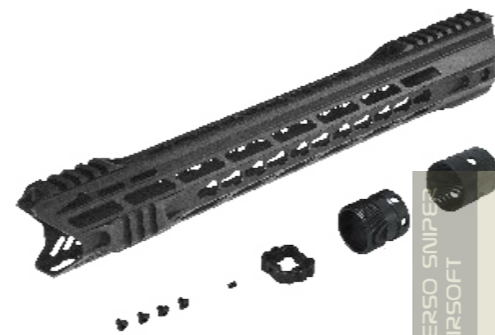

MARS Handguard 10" TAN
MARS 護木 10 吋

NEW MA-405 TAN 沙色



MARS Handguard 13" TAN
MARS 護木 13 吋

NEW MA-406 TAN 沙色



MARS Handguard 16" TAN
MARS 護木組 16 吋

NEW MA-407 TAN 沙色



YAK Keymod Handguard 10"
YAK Keymod 護木 10 吋

NEW MA-375 BK 黑色



YAK Keymod Handguard 10" TAN
YAK Keymod 護木 10 吋

NEW MA-378 TAN 沙色



YAK Keymod Handguard 12.5"
YAK Keymod 護木 12.5 吋

NEW MA-376 BK 黑色



YAK Keymod Handguard 12.5" TAN
YAK Keymod 護木 12.5 吋

NEW MA-379 TAN 沙色



YAK Keymod Handguard 15"
YAK Keymod 護木 15 吋

NEW MA-377 BK 黑色



YAK Keymod Handguard 15" TAN
YAK Keymod 護木 15 吋

NEW MA-380 TAN 沙色



MMR Handguard 10"
MMR 護木 10 吋

NEW MA-421 BK 黑色



MMR Handguard 10" TAN
MMR 護木 10 吋

NEW MA-424 TAN 沙色



MMR Handguard 13"
MMR 護木 13 吋

NEW MA-422 BK 黑色



MMR Handguard 13" TAN
MMR 護木 13 吋

NEW MA-425 TAN 沙色



MMR Handguard 15"
MMR 護木 15 吋

NEW MA-423 BK 黑色



MMR Handguard TAN
MMR 護木 15 吋

NEW MA-426 TAN 沙色



Handguard Accessories

護木配件

CS4A1 Delta Ring
CS4A1 護木固定環
MA-33



Delta Ring Wrench Tool
星狀環扳手組
MA-242



CS16A3 Front Handguard Ring
CS16A3 護木固定環
MA-69



APE Handguard Pin
APE 護木插銷
MA-302



CS4A1 Handguard Ring
CS4A1 護木固定環
MA-72



APE Barrel Ring
APE 槍管環
MA-303



CXP-08 Delta Ring
CXP-08 護木固定環
MA-100



HOG Handguard Retainer
HOG 護木固定環
MA-312



CS4A1 Tubular Handguard Delta Ring
星狀環 (圓管護木用)
MA-195



CXP-16 Handguard Retainer
CXP-16 護木定位座
MA-321



Wave Spring
波形彈簧
MA-196



CXP-16 Handguard Rear Retainer
CXP-16 護木後定位座
MA-323



Rail 軌道組

CXP Keymod Rail Set CXP Keymod 戰術軌道 - 長 MA-361



(Long Ver.)

Tactical Rail Handguard Panel Set-BK
R.I.S. 戰術護片 - 黑色
MA-52



Tactical Rail For Keymod Handguard
Keymod 快拆軌道 - 長
MA-220



(Long Ver.)

Tactical Rail Handguard Panel Set-TAN
R.I.S. 戰術護片 - 沙色
MA-177



Tactical Rail For Keymod Handguard
Keymod 快拆軌道 - 短
MA-221



(Short Ver.)

Keymod Panel (2pcs/set)
Keymod 護片 (2入)
MA-283



Keymod Bipod Mount
Keymod 腳架座組
MA-284



Carrying Handle 提把組

Detachable Carrying Handle
金屬提把組
MA-07



(Metal)

Detachable Carrying Handle
塑膠提把組
MA-135



(Plastic)

Wire Guard Assembly 線槽組

CS4 Wire Guard Assembly
CS4 線槽組
MA-23



UK1/HOG EBB Wire Guard Assembly
UK1/HOG 線槽組
MA-209



YAK Wire Guard Assembly
YAK 線槽組
MA-265



UK1 Wire Guard Assembly
UK1 線槽組
MA-337



(For Combination Gearbox)
(一體式齒輪箱用)

CXP Keymod Rail Set
CXP Keymod 戰術軌道 - 中
MA-362



(Medium Ver.)

CXP Keymod Rail Set
CXP Keymod 戰術軌道 - 短
MA-363



(Short Ver.)

CXP-08 Top Rail With Sight Set
CXP-08 規孔軌道組
MA-94



CXP-08 Handguard Tactical Rail Set
CXP-08 下護木軌道組
MA-102

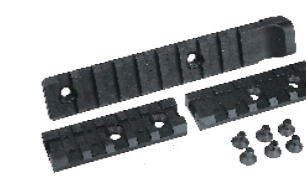

H-up Set H-up 組

CS4 H-up Set
CS4 H-up 組
MA-09



CS4 Metal H-up Set
CS4 金屬 H-up 組
MA-215



(For EBB & CS4)
(EBB & CS4 用)

APE H-up Set
APE H-up 組
MA-296



UK1 H-up Spring
UK1 H-up 定位壓簧
MA-216



APE H-up Spring
APE H-up 定位壓簧
MA-360



CXP-08 QRS Stock Patent Acquired: USD6070785 / ZL200730331142.7 / D124836
Crane Stock Patent Acquired: M351340 / ZL200820137077.3



UKSR Precision Adjustable Stock

UKSR 狙擊托

MA-364

PATENT ACQUIRED: EU-002686238-0001/
TW-D173288/TW-M517320



(W/O Stock Tube)
(不含槍托內管)

UKSR Sniper Stock-TAN

UKSR 狙擊托 沙色

NEW MA-382



(W/O Stock Tube)
(不含槍托內管)

APE Butt Plate
APE 槍托底板
MA-341



CXP-08 QRS Stock
CXP-08 伸縮托
MA-93



(For AEG)
(AEG 用)

QRS Tactical Retractable Stock
QRS 戰術伸縮托
MA-313 BK 黑色



(For EBB)
(EBB 用)

QRS Tactical Retractable Stock
QRS 戰術伸縮托
MA-317 TAN 沙色



(For EBB)
(EBB 用)

CS4 Stock Tube
CS4 伸縮托固定桿
MA-205



CS4 Stock Tube (Incl. Rear Cover)
CS4 伸縮托固定桿 (加底蓋)
MA-223



Charging Handle 槍機拉柄

CS4 Charging Handle
CS4 槍機拉柄
MA-30



EBB Ambi-Charging Handle
EBB 連動拉柄組
MA-212



APE Charging Handle
APE 拉柄組
MA-299



APE Charging Handle Assembly
APE 槍機拉柄組
MA-300



Receiver Pin 插銷

CS4 Front Receiver Pin
CS4 前槍身插銷
MA-21



CS4 Rear Receiver Pin
CS4 後槍身插銷
MA-25



YAK Rear Receiver Pin
YAK 後槍身插銷
MA-267



APE Rear Receiver Pin (2pcs/set)
APE 後槍身插銷
MA-290



Switch Assembly 電閘組

CS4 Switch Assembly For Fixed Stock
CS4 固定托電閘組
MA-39



CS4 Switch Assembly For Retractable Stock
CS4 伸縮托電閘組
MA-40



CS4 Power Cord Set (Front Wired)
CS4 伸縮托線材 (前出線)
MA-71

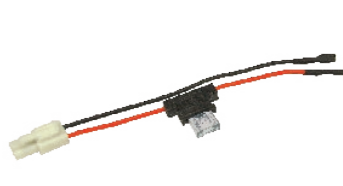

MAR Power Cord Set for Fixed Stock
MAR 固定托線材組
MK-36



MTR Carbine Stock
MTR 戰術伸縮托
MA-189



(W/O Stock Tube)
(不含槍托內管)

MTR Carbine Stock TAN
MTR 戰術伸縮托 - 沙色
MA-282



(W/O Stock Tube)
(不含槍托內管)

CS4 Retractable Stock (Incl. Stock Tube)
CS4 戰術伸縮托
MA-16 BK 黑色



CS4 Retractable Stock (Incl. Stock Tube)
CS4 戰術伸縮托
MA-169 TAN 沙色



MTR S1 Tactical Retractable Stock
MTR S1 戰術伸縮托
MA-318



(W/O Stock Tube)
(不含槍托內管)

MTR S1 Tactical Retractable Stock
MTR S1 戰術伸縮托
MA-325



(Incl. Stock Tube)
(附槍托固定桿)

Stock Tube & Rear Wired Gearbox Set
電池托套件組
MA-285



(For CXP EBB)
(CXP EBB 用)

UK1 Stock Spacer
UK1 槍托墊片
MA-314



APE Switch Assembly
APE 電閘組
MA-329



UK1 Captain Power Cord Set (Front Wired)
UK1 Captain 前出延長線材組
MA-359



EBB Rear Wired Switch Assembly (MTR stock)
EBB 後出線電閘組 (MTR 托)
MA-369



EBB Rear Wired Switch Assembly (Crane stock)
EBB 後出線電閘組 (海豹托)
MA-370



(Compatible with CS4 Crane Stock Series)
(與 CS4 海豹托共用)

MTR S1 Tactical Retractable Stock Patent Acquired: 002541334-0001 / USD7440485 / ZL201430345665.7 / D1531145 / D168410
MTR Carbine Stock Patent Acquired: D160112 / USD7068795



Gearbox 齒輪箱

Patent Acquired: US7077117B1 / M244431 / M480664



UK1 Combination Gearbox
UK1 一體式齒輪箱
MA-192

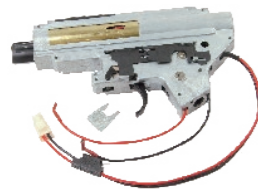

UK1 Lower Gearbox (Front Wired)
UK1 下齒輪箱 (前出線)
MA-194

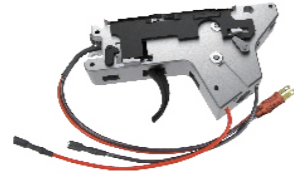

YAK Lower Gearbox
YAK (Rear Wired, for Crane Stock Ver.)
YAK 下齒輪箱
MA-263

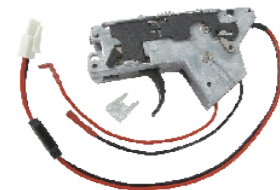

UK1/HOG/YAK Lower Gearbox
(Rear Wired, for MTR Stock Ver.)
UK1/HOG/YAK 下齒輪箱 (MTR 電池托用)
MA-273



Lower Gearbox 下齒輪箱

CS4 Lower Gearbox Shell (Empty)
CS4 下齒輪箱 (空)
MA-35

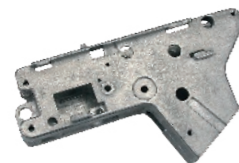

APE Lower Gearbox
APE 下齒輪箱
MA-289

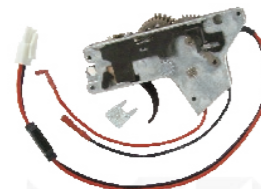

EBB Lower Gearbox Shell (Inc. screws)
EBB 下齒輪箱外殼 (含螺絲)
MA-336



CS4 Lower Gearbox
CS4 原廠下齒輪箱
MA-61



(Front Wired)
(前出線完成品)

CS4 Lower Gearbox
CS4 原廠下齒輪箱
MA-62



(Rear Wired)
(後出線完成品)

Upper Gearbox 上齒輪箱

CS4 Upper Gearbox Shell (Empty)
CS4 上齒輪箱 (空)
MA-34



EBB Upper Gearbox Shell (Inc. screws)
EBB 快拆式上齒輪箱外殼 (含螺絲)
MA-367



CS4 Standard Upper Gearbox Assembly (M100 Spring)
CS4 原廠上齒輪箱 (M100 彈簧 + 平拍頭)
MA-60



UK1/HOG/YAK EBB Upper Gearbox (M120 Spring)
UK1/HOG/YAK EBB 上齒輪箱
MA-193

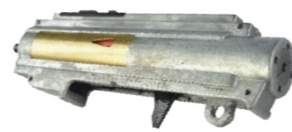

CS4 Standard Upper Gearbox Assembly (M120 Spring)
CS4 原廠上齒輪箱 (M120 彈簧 + 吸排氣頭)
MA-340



APE Upper Gearbox Assembly (M120 Spring)
APE 上齒輪箱
MA-293



Upgrade Gearbox Parts 升級齒輪箱套件

Ver. 2 Metal Spring Guide
二代尾頂桿
MC-43



Aluminum Cylinder & Piston Head Set (Oversized)
鋁活塞頭組 (加大)
MC-56



Oversized Cylinder (4 holes)
氣缸 (開四孔: 加大)
MC-58



Full Capacity Oversized Cylinder
全氣量加大氣缸
MC-71



Tappet Plate Delayer
上彈偏心軸
MC-102



Piston Head (Oversized)
活塞頭 (加大)
MC-93



Aluminum Cylinder Head (Oversized)
氣缸頭 (加大)
MC-91



Reinforced Upgrade POM Piston (Incl. Slice)
升級強化活塞
MC-170

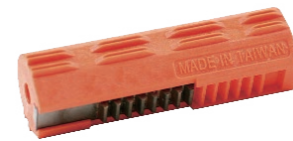

Reinforced Upgrade Piston Slice
升級強化活塞鋼片
MC-171



Reinforced Upgrade POM Piston (W/O Slice)
升級強化活塞 (不含鋼片)
MC-172



CS4/CES Metal Air Nozzle
CS4/CES 金屬推彈套筒
MA-344



Upgrade Upper Gearbox A (M120 Spring, Plastic Piston)
升級上齒輪箱組 -A
(M120 彈簧; 原廠塑膠活塞)
MA-47

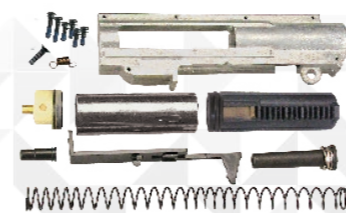

Upgrade Upper Gearbox B (M120 Spring, Aluminum Piston)
升級上齒輪箱組 -B
(M120 彈簧; 鋁活塞)
MA-48

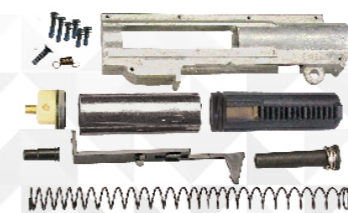

Upgrade Upper Gearbox D (M120 Spring, Aluminum Cylinder & Oversized Piston Head, 4 Opening Oversized Cylinder)
升級上齒輪箱組 -D
(M120 彈簧; 加大鋁活塞頭組; 開 4 孔加大氣缸)
MA-54



Upgrade Upper Gearbox F (M120 Spring, Aluminum Cylinder & Oversized Piston Head, Full Capacity Oversized Cylinder)
升級上齒輪箱組 -F
(M120 彈簧; 加大鋁活塞頭組; 全氣量加大氣缸)
MA-56



Upper Receiver 上槍身

CS4 Metal Upper Receiver
CS4 金屬上槍身

MA-31 BK 黑色
MA-174 TAN 沙色



CS4 Metal Upper Receiver Assembly
CS4 金屬上槍身組

MA-249



YAK Upper Receiver Assembly
YAK 上槍身組

MA-255 BK 黑色
MA-274 TAN 沙色



APE Upper Receiver Set
APE 上槍身

MA-297 BK 黑色
MA-308 TAN 沙色



HOG Upper Receiver Assembly
HOG 上槍身組

MA-310 BK 黑色
MA-315 TAN 沙色

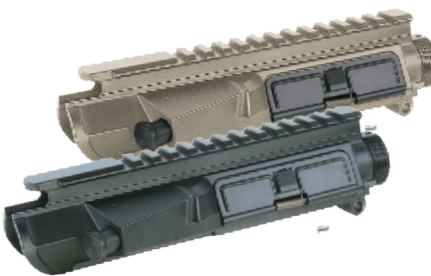

CXP-15 Reinforced Plastic Upper Receiver
CXP-15 塑膠上槍身

MA-248



CXP-16 Upper Receiver Assembly
CXP-16 上槍身組

MA-320 BK 黑色
MA-347 TAN 沙色



CXP-16 Plastic Upper Receiver Assembly
CXP-16 塑膠上槍身組

MA-348 BK 黑色
MA-349 TAN 沙色

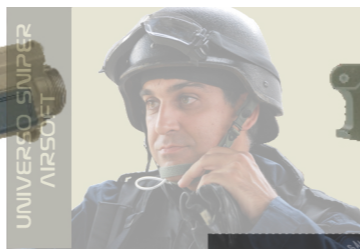

UK1 Upper Receiver Set
UK1 上槍身組

MA-330



(For Integrated Gearbox)
(一體式齒輪箱用)

UK1 Upper Receiver Assembly
UK1 上槍身組

MA-210 BK 黑色
MA-252 TAN 沙色



UK1 Upper Receiver Assembly(Incl. Charging Handle)
UK1 上槍身組 (含拉柄)

MA-250 BK 黑色
MA-251 TAN 沙色



Lower Receiver 下槍身

CS4 Metal Lower Receiver
CS4 金屬下槍身

MA-28B BK 黑色
MA-173 TAN 沙色



CXP Metal Lower Receiver
CXP 金屬下槍身

MA-28F BK 黑色
MA-247 TAN 沙色



UK1/HOG EBB Metal Lower Receiver
UK1/HOG EBB 金屬下槍身組

MA-207 BK 黑色
MA-253 TAN 沙色



YAK Lower Receiver Assembly
YAK 下槍身組

MA-264 BK 黑色
MA-275 TAN 沙色



APE Lower Receiver Assembly
APE 下槍身組

MA-286 BK 黑色
MA-305 TAN 沙色



UK1 Lower Receiver Set
UK1 下槍身組

MA-334



(For Integrated Gearbox)
(一體式齒輪箱用)

CXP Plastic Lower Receiver Assembly
CXP 塑膠下槍身組

MA-350 BK 黑色
MA-351 TAN 沙色



Receiver Set 槍身組

CS4 Upper & Lower Receiver Set (Sportline)
CS4 塑膠上下槍身

MA-140 BK 黑色
MA-227 TAN 沙色



CXP Upper & Lower Receiver Set (Sportline)
CXP 塑膠上下槍身

MA-145 BK 黑色
MA-206 TAN 沙色



UK1 Receiver Set for ICS-264C
UK1 一體式槍身

MA-191



UK1 Upper & Lower Receiver Assembly-TAN
UK1 金屬上下槍身組 - 沙色

MA-254





T Tactical Magazine T 戰術彈匣系列

Product Features

- Medium capacity and silenced design satisfy players needs for quiet motion in the battlefield.
- Screwless design allows fast assembly / disassembly.
- Compatible with CS4, CXP, AAR and L85/86 series. Available for both single package and 6 pieces per box.



T Tactical Hi-cap Magazine (300 Rounds)
T 戰術高容量彈匣 (300 發)

BK 黑色
MA-186 1 入裝 / 1pc
MA-243 6 入裝 / 6pcs/box

TAN 沙色
MA-240 1 入裝 / 1pc
MA-245 6 入裝 / 6pcs/box

T Tactical Mid-cap Magazine (120 Rounds)
T 戰術靜音彈匣 (120 發)

BK 黑色
MA-409 1 入裝 / 1pc
MA-413 6 入裝 / 6pcs/box

TAN 沙色
MA-410 1 入裝 / 1pc
MA-414 6 入裝 / 6pcs/box

T Tactical Low-cap Magazine (45 Rounds)
T 戰術靜音彈匣 (45 發)

BK 黑色
MA-187 1 入裝 / 1pc
MA-244 6 入裝 / 6pcs/box

TAN 沙色
MA-241 1 入裝 / 1pc
MA-246 6 入裝 / 6pcs/box



Others 彈匣配件

CS4/CS16 Magazine Clamp
CS4/CS16 彈匣連結器
MA-08

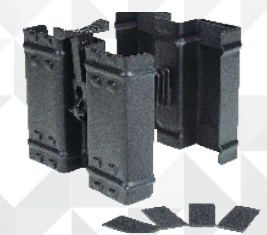

CS4 Ready Magazine System
CS4 彈匣預備槽
MA-20



CS4/CS16 Magazine Spring
CS4/CS16 彈匣發條彈簧片
MA-44

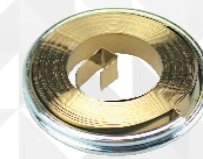

CS4/EBB Magazine Catch Set
CS4/EBB 彈匣卡榫
MA-22



YAK Magazine Catch Set
YAK 彈匣卡榫組
MA-266



APE Magazine Catch Set
APE 彈匣卡榫組
MA-287

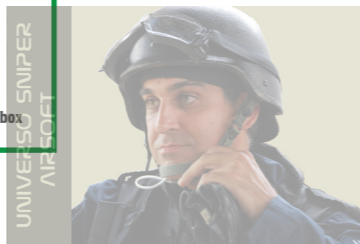

Canada C7 Magazine 加拿大 C7 彈匣

Canada C7 Hi-cap Magazine (300 Rounds)
加拿大 C7 高容量彈匣 (300 發)

Black 黑色
MA- 92 1 入裝 / 1pc
MA-156 6 入裝 / 6pcs/box

Canada C7 Hi-cap Magazine (300 Rounds)
加拿大 C7 高容量彈匣 (300 發)

Tan 沙色
MA-171 1 入裝 / 1pc



Metal Magazine 金屬彈匣

Metal Hi-cap Magazine (450 Rounds)
金屬高容量彈匣 (450 發)

MA- 04 1 入裝 / 1pc
MA-153 6 入裝 / 6pcs/box

Metal Mid-cap Magazine (120 Rounds)
金屬靜音彈匣 (120 發)

MA-411 1 入裝 / 1pc
MA-415 6 入裝 / 6pcs/box

Metal Low-cap Magazine (45 Rounds)
金屬靜音彈匣 (45 發)

MA-152 1 入裝 / 1pc
MA-154 6 入裝 / 6pcs/box



Tan 沙色

Metal Hi-cap Magazine (450 Rounds)
金屬高容量彈匣 (450 發)

MA-170 1 入裝 / 1pc

Metal Mid-cap Magazine (120 Rounds)
金屬靜音彈匣 (120 發)

MA-412 1 入裝 / 1pc
MA-416 6 入裝 / 6pcs/box



Metal Hi-cap Short Magazine (170 rounds)
金屬高容量短彈匣 (170 發)

Black 黑色
NEW MA-352 1 入裝 / 1pc

T4 Tactical Magazine T4 戰術彈匣

T4 Tactical Hi-cap Magazine (300 Rounds)
T4 戰術高容量彈匣 (300 發)

MA-148 1 入裝 / 1pc
MA-150 6 入裝 / 6pcs/box

T4 Tactical Low-cap Magazine (45 Rounds)
T4 戰術靜音彈匣 (45 發)

MA-151 6 入裝 / 6pcs/box



T4 Tacatical Hi-cap Magazine (300 Rounds)
T4 戰術高容量彈匣 (300 發)

Tan 沙色
MA-328 6 入裝 / 6pcs/box



QD Suppressor

滅音管



Front / Rear Sight 準星 / 照門

CS4 CQB Front Sight Base
CS4 CQB 前準星鏡座
MA-87



CXP-08 Front Sight Base
CXP-08 準星座
MA-97



Filp-up Rear Sight
簡易式照門
MA-17



CS4 Rear Sight Set
CS4 快瞄視孔組
MA-136



CXP Front Flip-Up Sight
CXP 彈跳式準星組
MA-160 BK 黑色
MA-162 TAN 沙色



CXP Rear Flip-Up Sight-BK
CXP 彈跳式快瞄視孔組
MA-161 BK 黑色
MA-163 TAN 沙色



CS4 Rear Sight Set
CS4 視孔組
MA-132



CS4 Folding Front Sight
CS4 前準星座組
MA-80



CS4 Front Sight Set
CS4 前準星組
MA-32



CS4/CS16 Front Sight Set(Incl. Sling)
CS4/CS16 前準星組 (含槍背帶環)
MA-67



APE Front Sight Set
APE 準星組
MA-298



UK1 Captain Front Sight Set
UK1 準星組
MA-353



NEW CFS Front Folding Sight-BK
CFS 摺疊準星組 - 黑色
MA-371



NEW CFS Rear Folding Sight-BK
CFS 摺疊視孔組 - 黑色
MA-372



NEW CFS Front Folding Sight-TAN
CFS 摺疊準星組 - 沙色
MA-373



NEW CFS Rear Folding Sight-TAN
CFS 摺疊視孔組 - 沙色
MA-374



APE Front Sight Set
APE 準星組
MA-298



UK1 Captain Front Sight Set
UK1 準星組
MA-353



Patent Acquired: 003568161-0001/003568161-0002/D184761



Flash Hider 防火帽

CS4/CS16 Birdcage
Flash Hider
CS4/CS16 制式防火帽
MA-02



C15 Flash Hider
C15 防火帽
MA-03



CXP-08 Flash Hider
CXP-08 防火帽
MA-96



CS4 Plastic Red Flash Hider
CS4 塑膠紅頭防火帽
MA-326



UK1 Plastic Red Flash Hider
UK1 塑膠紅頭防火帽
MA-327



Raider Flash Hider
突擊兵防火帽
MA-331



UK1 Flash Hider
UK1 防火帽
MA-219



Crown Flash Hider
鋼製皇冠防火帽
MA-356



Sling Swivel 背帶扣環

CS4 Front Sling Swivel Set
CS4 槍背帶扣環組
MA-05



CS4 Front Sling Swivel
CS4 快拆槍背帶扣環
MA-182



Sling Swivel Set For M1913 Rail System
CS4 前快拆槍背帶扣環
MA-84



QD Sling Swivel
快拆槍背帶扣環
MC-173



CXP-08 Front Sling Swivel
CXP-08 前槍背帶固定扣
MA-95



CS4 CQB Receiver End Cap
CS4 CQB 槍身後蓋組
MA-86



CS4 Sling Swivel For Retractable Stock
CS4 快拆伸縮托背帶扣環
MA-89



CS4 Sling Swivel For Folding Stock
CS4 折疊托背帶扣環
MA-90



CXP Ambidextrous Steel Sling Swivel
CXP 戰術背帶環
MA-164



CS4 Ambidextrous Steel Sling Swivel
CS4 戰術背帶環
MA-165



CXP-08 Cap For Front Sling Swivel (5pcs/Set)
CXP-08 前槍背帶固定扣螺帽 (5入)
MA-199



Outer Barrel 槍管組

CS4A1 Reinforced Outer
Barrel Set
CS4A1 槍管組
MA-10



CS16A3 Outer Barrel Set
CS16A3 槍管組
MA-68



CS4 CQB Reinforced Outer
Barrel Set
CS4 CQB 槍管
MA-83



CXP-08 Outer Barrel Set
CXP-08 槍管組
MA-99



CS4 Commando Reinforced
Outer Barrel Set
CS4 Commando 槍管
MA-131



UK1/HOG Reinforced Outer Barrel Set
UK1/HOG 槍管組
MA-217 (10.5")
MA-225 (14")



CXP-15 Outer Barrel Set
CXP-15 槍管組
MA-237 (Metal)
MA-238 (Plastic)

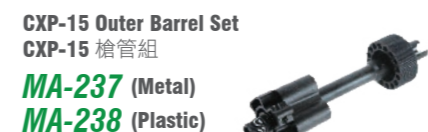

YAK/CXP-APE Outer Barrel Set
YAK/CXP-APE 槍管組
MA-256 (10.5")
MA-257 (14.5")
MA-258 (16.75")
*MA-258 is only for PAR Mk3



CXP-16 Outer Barrel Set
CXP-16 槍管組
MA-322 (11.8")



Grip 握把

CS4 Pistol Grip
CS4 握把
MA-37



CS4 MTS Tactical Grip
CS4 MTS 戰術握把
MA-137 BK 黑色



UK1 Tactical Grip
UK1 戰術握把
MA-190 BK 黑色



APE Pistol Grip
APE 握把
MA-288 BK 黑色



Bipod Foregrip
腳架握把
MA-79 BK 黑色



UK1 MTS Tactical Grip
UK1 MTS 戰術握把
MA-333



CS4 MTS Tactical Grip
CS4 MTS 戰術握把
MA-167 TAN 沙色



UK1 Tactical Grip
UK1 戰術握把
MA-271 TAN 沙色

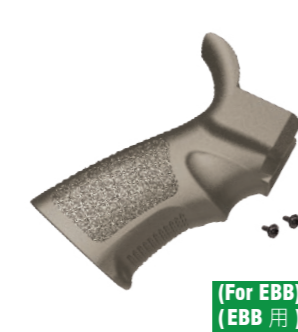

APE Pistol Grip
APE 握把
MA-306 TAN 沙色



Bipod Foregrip
腳架握把
MA-176 TAN 沙色



CS4 Grip Butt Cap
CS4 握把底蓋
MA-36



UK1 Tactical Grip Butt Cap
UK1 戰術握把底蓋
MA-270



CS4 MTS Tactical Grip Butt Cap
CS4 MTS 戰術握把底蓋
MA-365 BK 黑色



CS4 MTS Tactical Grip Butt Cap
CS4 MTS 戰術握把底蓋
MA-366 TAN 沙色



Others 其他

CS4 Anti-Reversal Lever
CS4 止逆轉釋放連桿
MA-14



CS4/CS16/CXP Switch Plate
電閘組開關片
MA-45

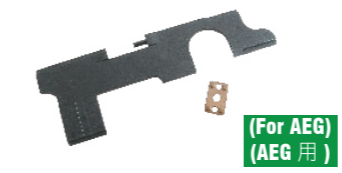

Metal Switch Plate
金屬電閘組開關片
MA-338



CS4 Gearbox Screw Set
CS4 齒輪箱螺絲組
MA-139



CS4 Gearbox Screw Set (New Version)
CS4 齒輪箱螺絲組 (新版)
MA-185



CS4 Trigger
CS4 扳機
MA-57



CS4 Forward Assist Assembly
CS4 槍機助進器
MA-41



CS4 Selector Lever Set
CS4 選擇鈕套件
MA-51



CS4 Motor Spacer
CS4 馬達墊片
MA-63



CS4 CQB Battery Box
CS4 CQB 外掛電池組
MA-82



CS4/CXP EBB QD Spring Guide
CS4/CXP EBB 齒輪箱用快拆式尾頂桿
MA-332



UK1 Captain Receiver Extension Tube
UK1 Captain 槍身尾桿組
MA-358



APE Nozzle
APE 推彈套筒
MA-295



CES/CS4 Nozzle
CES/CS4 推彈套筒
MP-23



CS4/CES Metal Air Nozzle
CS4/CES 金屬推彈套筒
MA-344



UK1/HOG Decorated Bolt Cover Set
UK1/HOG 退彈口飾片組
MA-213



UK1/HOG Bolt Cover Spring
UK1/HOG 飾片彈簧
MA-214



APE Decorated Bolt Cover Set
APE 退彈口飾片組
MA-294



APE Stock Button
APE 槍托壓鈕
MA-292



Ver.2 Metal Spring Guide
二代尾頂桿
MC-43



CS4/CES Cut-Off Lever
CS4/CES 單連發控制桿
MC-20



MAR

高環境適性步槍
SERIES

With the perfect metal body, excellent performance and characteristics found in all ICS products, the ICS MAR displays the beauty of the legend.

The ICS MAR series features full metal construction including the receivers, outer barrel, front and rear sights, sling mounts, mag release, front barrel assembly, flash hider, and charging handle,...etc.

The MAR series is durable and realistic. It comes with unique serial number and steel bushing in a compact design.



UNIVERSO SNIPER AIRSOFT

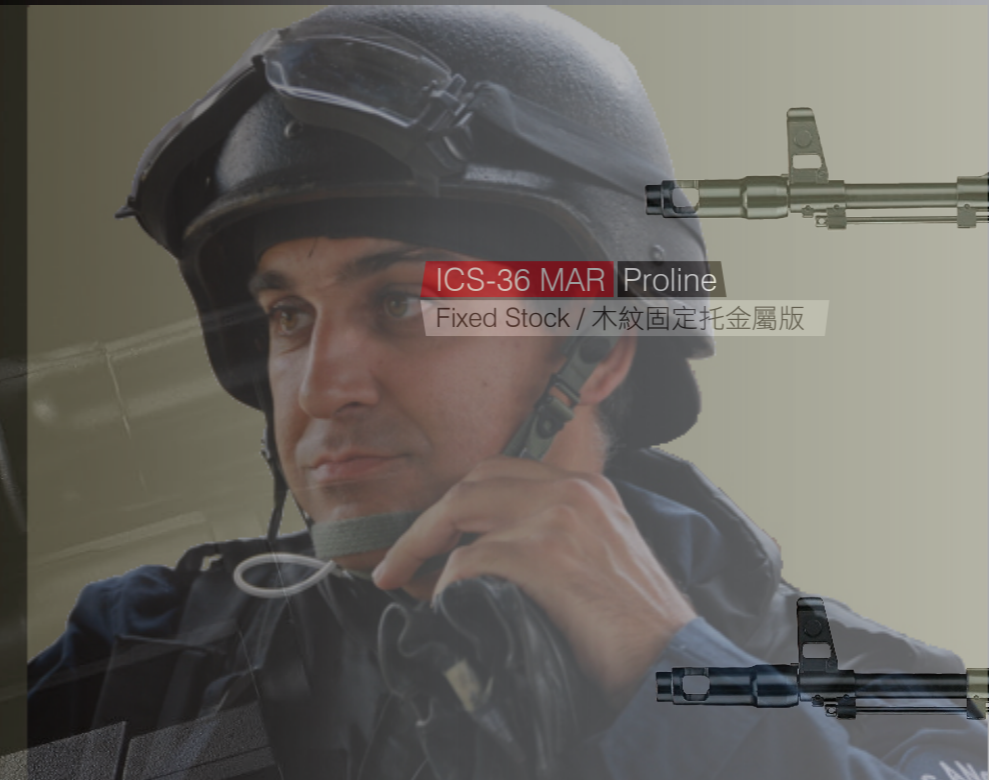



ICS-36 MAR Proline
Fixed Stock / 木紋固定托金屬版



ICS-37 MAR SN Proline
Folding Stock / 折疊托金屬版



	ICS-36 	ICS-37 
Length/Retractable	960 (mm)	960/715 (mm)
Barrel length (mm)	458	458
Muzzle velocity	115-137 m/s (377-449 FPS) ※	122-137 m/s (400-449 FPS) ※
Weight (g)	3314	3100
Battery type	9.6V Ni-Mh or 11.1V Li-Po	9.6V Ni-Mh or 11.1V Li-Po
Connector size	Small connector	Small connector
Mag. capacity	550	550
Spring	M120	M120
Material	Full metal	Full metal
Motor axle	Short	Short



※ NOTE:
 1. The product specification is for reference only and may be subject to change.
 2. Battery type is recommended, not included.
 3. For AEG with M100 spring, it is recommended to use voltage 7.4V Li-Po or 9.6V Ni-Mh batteries.
 4. Muzzle velocity is measured with 0.20g BB's, and is adjusted to comply with market regulation/requirements for specific countries as shown below:
 Below 106 m/s (350 FPS): Belgium, France, Netherlands, Portugal, Spain, UK
 Below 100 m/s (328 FPS): Italy
 Below 95 m/s (312 FPS): Japan
 Below 45 m/s (148 FPS): Korea

MAR S

俄羅斯聯邦制式步槍



Front Sight Set



Realistic Handguard Disassembly Design



Stamping Made Receiver



Adjustable H-up



ICS-34 MAR SU Proline
Folding Stock / 折疊托金屬版



Real Gun Design, Dewaxing Processes MAR SU / MAR M

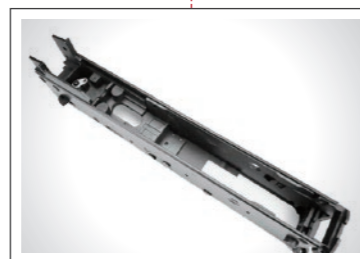

Steel Plate Made Receiver



Real Steel Welding Look & Easy to Change to MAR M Stock

MAR SU / MAR M

俄羅斯聯邦制式步槍



ICS-32 MAR R.A.S. Proline
Fixed Stock / 固定托金屬版



ICS-35 MAR M Proline
Folding Stock / 折疊托金屬版

	ICS-32	ICS-34	ICS-35
Length/Retractable	965 (mm)	745/510 (mm)	964/714 (mm)
Barrel length (mm)	458	263	458
Muzzle velocity	115-137 m/s (377-449 FPS) ※	115-134 m/s (377-440 FPS) ※	115-137 m/s (377-449 FPS) ※
Weight (g)	3200	2700	3000
Battery type	9.6V Ni-Mh or 11.1V Li-Po	9.6V Ni-Mh or 11.1V Li-Po	9.6V Ni-Mh or 11.1V Li-Po
Connector size	Small connector	Small connector	Small connector
Mag. capacity	550	550	550
Spring	M120	M120	M120
Material	Full metal	Full metal	Full metal
Motor axle	Short	Short	Short

※ NOTE:

- The product specification is for reference only and may be subject to change.
- Battery type is recommended, not included.
- For AEG with M100 spring, it is recommended to use voltage 7.4V Li-Po or 9.6V Ni-Mh batteries.
- Muzzle velocity is measured with 0.20g BB's, and is adjusted to comply with market regulation/requirements for specific countries as shown below:
 Below 106 m/s (350 FPS): Belgium, France, Netherlands, Portugal, Spain, UK
 Below 100 m/s (328 FPS): Italy
 Below 95 m/s (312 FPS): Japan
 Below 45 m/s (148 FPS): Korea

UNIVERSO SNIPER AIRSOFT



MAR SERIES Compatible Parts

Gearbox

齒輪箱

MAR Gearbox Assembly MAR 齒輪箱 (後出線完成品) MK-44



MAR Gearbox Shell (Empty)
MAR 齒輪箱 (空)
MK-26



Ver.3 Tappet Plate
撥彈連桿
MK-29



MAR Switch Assembly
MAR 電閘組線材
MK-32



MAR Motor Case
MAR 馬達座組
MK-39



CES/MAR Anti-Reversal Latch
CES/MAR 止逆轉組
MC-60



MAR Cut-off Lever
MAR 單連發控制桿
MK-33



M3/MAR Gearbox Spacer Plate
M3/MAR 齒輪箱固定片
MK-27



MAR Switch Plate
MAR 電閘開關片
MK-30



MAR Power Cord Set for Fixed Stock
MAR 固定托線材組
MK-36



(Compatible with CS4 Crane Stock Series)
(與 CS4 海豹托共用)

MAR Gearbox Screw Set
MAR 齒輪箱螺絲組
MK-40



MAR Trigger Plate
MAR 射擊連動片
MK-43



MAR Plastic Spring Guid
MAR 塑膠尾頂桿
MK-28



MAR Switch Copper Plate
MAR 電閘開關銅片
MK-31



Sector Gear Cover
3 號齒輪外蓋
MK-37



MAR Gearbox Spring Set
MAR 齒輪箱彈簧組
MK-41



MAR Selector Plate
MAR 選擇片
MK-53



Receiver 槍身

MAR Upper Receiver Cover
MAR 有助機匣蓋
MK-19



MAR Upper Receiver Button
MAR 機匣蓋開關
MK-35



MAR Receiver Mount
MAR 槍身基座
MK-25



MAR Dummy Cleaning Rod
MAR 通槍條
MK-09



MAR Flat Upper Receiver Cover
MAR 無助機匣蓋
MK-45



MAR M/MAR SU Battery Base Set
MAR M/MAR SU 電池座
MK-59



MAR Lower Receiver Set
MAR 槍身組
MK-17



Barrel 槍管組

MAR Gas Tube Retainer Set
MAR 瓦斯管座
MK-06



MAR SU Upper Receiver Cover
MAR SU 規孔機匣組
MK-66



MAR Side Mount
MAR 鏡軌座 (2 件)
MK-48



MAR M/MAR SU Receiver Set
MAR M/MAR SU 槍身組
MK-56



MAR Reinforced Outer Barrel
MAR 槍管
MK-10



MAR Charging Handle Set
MAR 槍機拉柄組
MK-18



MAR Side Mount
MAR 鏡軌座組 (3 件)
MK-49



MAR M/MAR SU Stock Hook
MAR M/MAR SU 固定勾
MK-70



MAR SU Reinforced Outer Barrel
MAR SU 槍管
MK-65



MAR M/MAR SU Charging Handle
MAR M/MAR SU 槍機拉柄組
MK-69



MAR Scope Mount Base
MAR 鏡座
MK-50



Handguard

護木

MAR Upper Handguard (Wooden) MAR 上護木組 (實木) MK-73



MAR Lower Handguard (Wooden)
MAR 下護木組 (實木)
MK-74

MAR Lower Handguard
MAR 下護木
MK-02

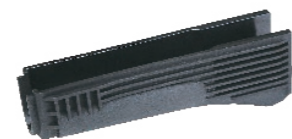

MAR R.A.S. Tactical Handguard Set
MAR R.A.S. 戰術護木組
MK-47



MAR R.A.S. Tactical Handguard Set
MAR R.A.S. 戰術護木組
MK-51



MAR M Upper Handguard
MAR M 上護木組
MK-54



MAR SU Upper Handguard (Wooden)
MAR SU 上護木組 (實木)
MK-61



MAR SU Lower Handguard (Wooden)
MAR SU 下護木組 (實木)
MK-62



MAR Upper Handguard Lever
MAR 上護木固定鈕組
MK-14



MAR Lower Handguard Ring
MAR 下護木環
MK-05



MAR SU Lower Handguard Ring
MAR SU 下護木環
MK-64



Stock 後托

MAR Fixed Stock (Wooden)
MAR 固定托 (實木)
MK-72



MAR Wooden Stock Kit
MAR 護木固定托組 (實木)
MK-75



MAR Butt Plate
MAR 固定托底板
MK-24



MAR Fixed Stock
MAR 固定托
MK-23



MAR M Folding Stock
MAR M 折疊托
MK-57



MAR SU Triangle Folding Stock
MAR SU 三角折疊托
MK-58



Other 其他

MAR Front Sight
MAR 前準星組
MK-07



MAR Rear Sight Ruler
MAR 視孔表尺組
MK-13



MAR Rear Sight Set
MAR 視孔座組
MK-16

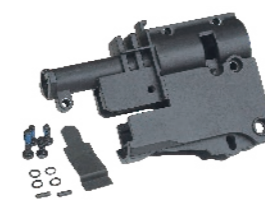

MAR SU Front Sight Set
MAR SU 準星組
MK-60



MAR Grip
MAR 握把
MK-22



MAR Hi-Cap Magazine (550 Rounds)
MAR 高容量彈匣 (550 發)
MK-01 1 入裝 / 1pc
MK-90 6 入裝 / 6pcs/box



MAR Magazine Catch Block
MAR 彈匣卡座
MK-42



MAR M/MAR SU Magazine Mount Set
MAR M/MAR SU 彈匣擋片
MK-71



MAR Trigger Guard
MAR 護弓組
MK-21



MAR Tactical Folding Grip
MAR 戰術折疊握把
MK-52



MAR H-up Set
MAR H-up 組
MK-12



MAR M/MAR SU H-up Set
MAR M/MAR SU H-up 組
MK-55



MAR Fire Select Lever
MAR 射擊選擇桿組
MK-20



MAR Sling Swivel Set
MAR 槍托背帶扣組
MK-46



MAR Trigger Set
MAR 扳機組
MK-34



Flash Hider 防火帽

MAR/MAR M Flash Hider
MAR/MAR M 防火帽
MK-08



MAR SU Flash Hider
MAR SU 防火帽
MK-63



WORLD WAR II



M1 GRAND

As a part of the history and almost 70 years past, people still remember the image that en clips lay down in foxhole, the noise of "Ping" sound, and the smell of 30-06 rounds.

All these combined with courage, honor and discipline had created stories to share. All of these stories build up a role model to follow.

From WWII, Korea to Vietnam, The war has changed, but the spirits are never fade away.

A Legend that ICS shouldn't miss, The M1 Garand.

M3 二戰槍系列 - M3黃油槍 SUBMACHINE GUN

ICS launched the M3 submachine gun (ICS-200) in 2011 which is designed with innovative concept and creative features that give the M3 submachine gun the newest construction and immersive performance.

The player who adores scenes and objects from World War II would enjoy the fun and realistic war effect that offered by the ICS M3 capability.

Photography by Morten Kirsted

UNIVERSO SNIPER AIRSOFT



Wooden Gun Case



Trophy Mount



Bolt Carrier



Spatial Battery Room



ICS-201L M1 GARAND LIMITED Proline

Fixed Stock / 固定托 8mm 限量特仕紀念版



Realistic Sights & Engraved Serial Number



ICS-202 M1 GARAND Proline

Fixed Stock / 固定托 6mm 木紋全金屬版



Classic Real Leather Sling



ICS-201L ICS-202

	ICS-201L	ICS-202
Length/Retractable	1100 (mm)	1100 (mm)
Barrel length (mm)	610	610
Muzzle velocity	80-87 m/s (262-285 FPS) ※	118-135 m/s (387-443 FPS) ※
Weight (g)	3600	3600
Battery type	9.6V Ni-Mh or 11.1V Li-Po	9.6V Ni-Mh or 11.1V Li-Po
Connector size	Small connector	Small connector
Mag. capacity	25	42
Spring	M120	M120
Material	Metal/Wood	Metal/Wood
Motor axle	Short	Short

※ NOTE:
 1. The product specification is for reference only and may be subject to change.
 2. Battery type is recommended, not included.
 3. For AEG with M100 spring, it is recommended to use voltage 7.4V Li-Po or 9.6V Ni-Mh batteries.
 4. Muzzle velocity is measured with 0.20g BB's, and is adjusted to comply with market regulation/requirements for specific countries as shown below:
 Below 106 m/s (350 FPS): Belgium, France, Netherlands, Portugal, Spain, UK
 Below 100 m/s (328 FPS): Italy
 Below 95 m/s (312 FPS): Japan
 Below 45 m/s (148 FPS): Korea

M1 SERIES Compatible Parts

Handguard

護木

M1 Stock Set M1 槍托護木組 ME-27



M1 Stock
M1 槍托
ME-03



M1 Cylinder Head (8mm)
M1 氣缸頭 (8mm)
ME-40



M1 Cylinder Head (6mm)
M1 氣缸頭 (6mm)
ME-41

M1 Upper Handguard (Wood, Front)
M1 前段護木
ME-18



M1 Upper Handguard (Wood, Rear)
M1 後段護木
ME-21



M1 Trigger Assembly
M1 扳機組
ME-02



M1 H-up Spring
M1 H-up 壓簧
ME-13



M1 H-up Set
M1 H-up 組
ME-14 (6mm)
ME-33 (8mm)



M1 Bolt Carrier
M1 槍機蓋板
ME-15



M1 Receiver
M1 上槍機室組
ME-16



M1 Gas Tube (Front)
M1 前槍管組
ME-17



M1 Butt Plate Cover
M1 槍托電池蓋
ME-04



M1 Butt Plate Set
M1 槍托底蓋組
ME-05



M1 Power Cord Set
M1 線材組
ME-06



M1 Sling Swivel & Handguard Ring
M1 護木固定環組
ME-19



M1 Front Sight
M1 準星組
ME-20



M1 Handguard Bracket
M1 護木定位片
ME-22



M1 Charging Handle Pin
M1 拉柄導桿固定銷
ME-23



M1 Motor Case
M1 馬達固定座組
ME-24



M1 Charging Handle Rod
M1 拉柄導桿
ME-07



M1 Bolt Carrier Spring
M1 槍機覆進簧
ME-08



M1 Gas Tube Buffer Spring
M1 瓦斯管緩衝壓簧
ME-09



M1 Trigger Contact Switch Assembly (Male)
M1 插板座組
ME-25



M1 Trigger Contact Switch Assembly (Female)
M1 電閘組
ME-26



M1 MOSFET
M1 MOSFET 電閘開關
ME-28



M1 Gearbox (Incl. Bushings)
M1 齒輪箱 - 空 (含軸承)
ME-31



M1 H-up Bucking (8mm)
含彈橡皮 (8mm)
ME-34



M1 Charging Handle Set
M1 槍機拉柄組
ME-10



M1 Gearbox Set
M1 齒輪箱組
ME-11 (6mm)
ME-32 (8mm)



M1 Outer Barrel
M1 槍管組
ME-12 (6mm)
ME-36 (8mm)



M1 Nozzle (6mm)
M1 推彈套筒 (6mm)
ME-30



M1 Nozzle (8mm)
M1 推彈套筒 (8mm)
ME-38



M1 Tappet Plate
M1 撥彈連桿
ME-29 (6mm)
ME-39 (8mm)



M1 Magazine (6mm, 42 Rounds)
M1 彈匣 (6mm, 42 發)
ME-01



M1 Magazine (8mm, 25 Rounds)
M1 彈匣 (8mm, 25 發)
ME-37



M3 SUBMACHINE GUN 二戰槍系列 - M3 黃油槍



Complex Metalline Materials Application



ICS-200 M3 Submachine Gun Proline
Retractable Stock / 伸縮托 金屬版



Realistic Appearance Details



Integrated H-up, Realistic Cocking Handle & Realistic Automatic Firing



High Capacity Metal Magazine (430 rounds)

New Developing M3 Gearbox (8mm Metal Bushings)

	ICS-200
Length/Retractable	762.5/587 (mm)
Barrel length (mm)	230
Muzzle velocity	115-128 m/s (377-420 FPS) ※
Weight (g)	2045
Battery type	9.6V Ni-Mh or 11.1V Li-Po
Connector size	Small connector
Mag. capacity	430
Spring	M120
Material	Full metal
Motor axle	Short

※ NOTE:
 1. The product specification is for reference only and may be subject to change.
 2. Battery type is recommended, not included.
 3. For AEG with M100 spring, it is recommended to use voltage 7.4V Li-Po or 9.6V Ni-Mh batteries.
 4. Muzzle velocity is measured with 0.20g BB's, and is adjusted to comply with market regulation/requirements for specific countries as shown below:
 Below 106 m/s (350 FPS): Belgium, France, Netherlands, Portugal, Spain, UK
 Below 100 m/s (328 FPS): Italy
 Below 95 m/s (312 FPS): Japan
 Below 45 m/s (148 FPS): Korea

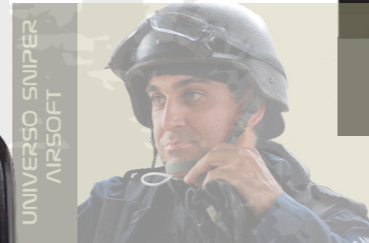

M3 SERIES

Compatible Parts

零件

M3 Outer Barrel
M3 槍管
MY-01



M3 H-up Assembly (Incl. Inner Barrel)
M3 H-up 組
MY-02



M3 H-up Set
M3 H-up 組
MY-03



M3 Standard Gearbox Assembly
M3 齒輪箱 (完成品)
MY-04



M3 Gearbox Shell
M3 齒輪箱 (空)
MY-05



M3 Anti-reversal Latch
M3 止逆轉組 (含彈簧)
MY-06



M3 Safety Linking Plate
M3 保險連動片
MY-07



M3 Motor Spring
M3 馬達調整彈簧
MY-08



M3 Switch Set
M3 電匣組
MY-09



M3 Motor Case
M3 馬達座組
MY-10



M3 Housing Assembly
M3 槍身下蓋組
MY-11



M3 Trigger Guard
M3 扳機護弓
MY-12



M3 Stock Catch Set
M3 槍托配件
MY-13



M3 Metal Receiver (Aluminum)
M3 金屬槍身 (鋁)
MY-14



M3 Magazine Catch Button
M3 退彈卡榫
MY-15



M3 Rear Sight
M3 規孔座
MY-16



M3 Butt Cap
M3 槍身後蓋
MY-17



M3 Stock
M3 槍托
MY-18



M3 Hi-cap Metal Magazine (430 Rounds)
M3 高容量彈匣 (430 發)

MY-19 1入裝/1pc



M3 Low-cap Magazine (140 Rounds)
M3 靜音彈匣 (140 發)

MY-20 1入裝/1pc

L85A2

英國皇家突擊步槍

The unique features and innovations make ICS L85 A2 series the excellent AEGs For play and collection.

ICS-85 L85A2 Proline
Fixed Stock / 固定托 金屬版



Comes with instant releasable, stamped steel upper and lower receivers, patented newly designed delayed-action trigger mechanism, the ICS L85 power is off when detaching the upper and lower receivers.

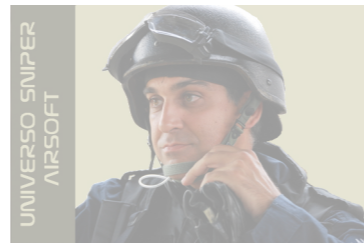

Brand new gearbox set with adjustable spring strength.



ICS-87 L85A2 Carbine Proline

Fixed Stock / 固定托 金屬版



	ICS-85 	ICS-87 
Length/Retractable	786.5 (mm)	740 (mm)
Barrel length (mm)	480	420
Muzzle velocity	116-139 m/s (382-456 FPS) ※	118-136 m/s (387-446 FPS) ※
Weight (g)	3652	3090
Battery type	9.6V Ni-Mh or 11.1V Li-Po	9.6V Ni-Mh or 11.1V Li-Po
Connector size	Small connector	Small connector
Mag. capacity	450	450
Spring	M120	M120
Material	Full metal	Full metal
Motor axle	Short	Long

※ NOTE:

1. The product specification is for reference only and may be subject to change.
2. Battery type is recommended, not included.
3. For AEG with M100 spring, it is recommended to use voltage 7.4V Li-Po or 9.6V Ni-Mh batteries.
4. Muzzle velocity is measured with 0.20g BB's, and is adjusted to comply with market regulation/requirements for specific countries as shown below:
Below 106 m/s (350 FPS): Belgium, France, Netherlands, Portugal, Spain, UK
Below 100 m/s (328 FPS): Italy
Below 95 m/s (312 FPS): Japan
Below 45 m/s (148 FPS): Korea

L85A2 CARBINE

英國皇家突擊步槍



L85 / L86 SERIES Compatible Parts

L85/L86 共用零件系列

L85/L86 Upper Receiver Set L85/L86 上槍身組 ML-13



L85 Lower Receiver Set
L85 下槍身組
ML-09

L86 Lower Receiver Set
L86 下槍身組
ML-45

L85 Flash Hider
L85 防火帽
ML-03



L86 Flash Hider
L86 防火帽
ML-19



L85 Handguard Assembly
L85 護木組
ML-01



L86 Handguard Set
L86 護木組
ML-25



L85A2 Carbine Handguard Set
L85A2 卡賓護木組
ML-36



L85/L86 Front Sight Assembly
L85/L86 準星組
ML-02



L85 Butt Plate Set
L85 槍托組
ML-06



L86 Butt Plate Set
L86 槍托組
ML-23



L85/L86 H-up Set
L85/L86 H-up 組
ML-07



L85/L86 Pistol Grip Set
L85/L86 握把組
ML-10



L86 Foregrip Set
L86 輔助握把組
ML-22



L85/L86 Detachable Carrying
Handle Assembly
L85/L86 提把組
ML-12



L86 Bipod Set
L86 腳架組
ML-24



L85/L86 M1913 21mm Tactical Rail
L85/L86 M1913 21mm 鏡軌座
ML-28



L85/L86 Gas Tube Set
L85/L86 瓦斯管組
ML-11



L85/L86 Charging Handle Set
L85/L86 槍機拉柄組
ML-15



L85 Outer Barrel Set
L85 槍管組
ML-04



L86 Outer Barrel Set
L86 槍管組
ML-20



L85A2 Carbine Outer Barrel Set
L85A2 卡賓槍管組
ML-34



L85/L86 Gearbox Assembly
L85/L86 齒輪箱 (完成品)
ML-16



L85/L86 Metal Spring Guide
L85/L86 金屬尾頂桿
ML-17



L85/L86 Switch Assembly
L85/L86 電開板機組
ML-08

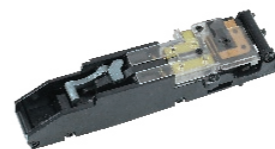

L85/L86 Upper Connect Set
L85/L86 上接點組
ML-14

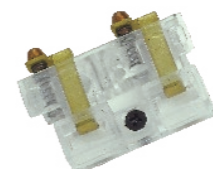

L85/L86 Motor Case
L85/L86 馬達座組
ML-18



L85/L86 Spring Set
L85/L86 彈簧組
ML-32



L85/L86 Receiver Pin
L85/L86 槍身插銷
ML-26



L85/L86 Rear Receiver Pin
L85/L86 後槍身插銷
ML-27



L85/L86 Tappet plate
L85/L86 撥彈連桿
ML-30



L85/L86 Switch Assembly
L85/L86 線材組
ML-37



L85/L86 Metal Nozzle
L85/L86 金屬推彈套筒
ML-38



L85/L86 Anti-Reversal Latch Set
L85/L86 止逆轉組
ML-33



L85/L86 Cheek Rest
L85/L86 貼腮板
ML-39



L85/L86 Fire Selector Set
L85/L86 射擊選擇鈕組
ML-40



L85 Magazine Catch Button
L85 彈匣釋放鈕
ML-41



L85 Cut-off Lever
L85 單發歸位連桿
ML-42



L85/L86 Gearbox Shell (Inc. screws)
L85/L86 齒輪箱外殼 (含螺絲)
ML-43



AAR

全新 AAR 次世代的戰術版槍型 SERIES

The AAR with SFS (Situation Flexible Stock) has not only a stock folding feature, but also a stock pad of 4 adjustable lengths, and ambidextrous QD sling swivel mounts on both sides.



Photography by courtesy of David McCunnie
resident photographer at Section8
Model: Steven Allan Mcallister

Patents acquired:
US D706,880 S / D 159178 / D 137321 / ZL 201030002113.8 / 002246579-0001



ICS-233 AAR Black | Proline
SFS Stock / SFS 狙擊折疊托
(non available in US and Canada)

- Compatible with standard CS4 magazine
- Improved tactical handguard allows more options for tactical setup
- Custom SFS (Situation Flexible Stock)
- Fire selector from either side for action agility and task accomplishment
- Magazine release mechanism



QD Sling Swivel (Not Included)



ICS-234 AAR Tan | Proline
SFS Stock / SFS 狙擊折疊托
(non available in US and Canada)

ICS-235 AAR Two-Tone | Proline
SFS Stock / SFS 狙擊折疊托
(non available in US and Canada)



ICS-233	ICS-234	ICS-235
---------	---------	---------

Length/Retractable	515/746/795 (mm)
Barrel length (mm)	263
Muzzle velocity	115-134 m/s (377-440 FPS) ※
Weight (g)	2550
Battery type	9.6V Ni-Mh or 11.1V Li-Po
Connector size	Small connector
Mag. capacity	300
Spring	M120
Material	Engineering plastic
Motor axle	Short

※ NOTE:
1. The product specification is for reference only and may be subject to change.
2. Battery type is recommended, not included.
3. For AEG with M100 spring, it is recommended to use voltage 7.4V Li-Po or 9.6V Ni-Mh batteries.
4. Muzzle velocity is measured with 0.20g BB's, and is adjusted to comply with market regulation/requirements for specific countries as shown below:
Below 106 m/s (350 FPS): Belgium, France, Netherlands, Portugal, Spain, UK
Below 100 m/s (328 FPS): Italy
Below 95 m/s (312 FPS): Japan
Below 45 m/s (148 FPS): Korea

AAR SERIES Compatible Parts

AAR 共用零件系列

AAR Bolt Release Set (Non-functional)
AAR 槍機釋放鈕 (裝飾用)
MH-05

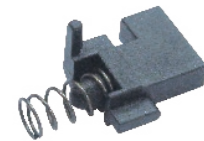

AAR Fire Select Set
AAR 射選連動齒組
MH-06



AAR Gearbox Pin
AAR 齒輪箱固定銷
MH-07



AAR Magazine Catch Button Set
AAR 退彈匣按鈕組
MH-09



AAR Magazine Catch Lever Set
AAR 退彈匣旋鈕組
MH-10



AAR Receiver Pin
AAR 槍身插銷組
MH-11

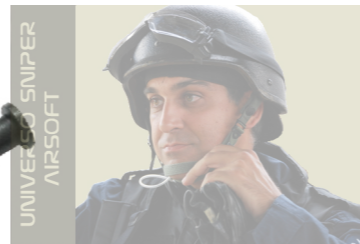

AAR Gearbox Assembly
AAR 齒輪箱組
MH-12



AAR Stock Mount (Incl. Sling Swivel)
AAR 槍托固定座組
MH-15



AAR Front Sight
AAR 準星組
MH-17



AAR Rear Sight Set
AAR 覘孔組
MH-18



AAR H-up Set
AAR H-up 組
MH-19



AAR Outer Barrel Set
AAR 槍管座組
MH-20



AAR Nozzle
AAR 推彈套筒
MH-31



AAR Switch Assembly
AAR 電開組線材
MH-32



AAR Fire Select Plate
AAR 射選連動片
MH-33



AAR Stock Release Button
AAR 可調式折疊托固定鈕
MH-34

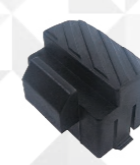

AAR Flash Hider
AAR 防火帽
MH-21



AAR Plastic Red Flash Hider
AAR 塑膠紅頭防火帽
MH-38



Black Series 黑色版

AAR Lower Receiver-BK
AAR 下槍身 - 黑色
MH-01



AAR Magazine Housing Assembly-BK
AAR 槍身下蓋 - 黑色
MH-08



AAR Upper Receiver-BK
AAR 上槍身組 - 黑色
MH-13



AAR Charging Handle Set-BK
AAR 槍機拉柄組 - 黑色
MH-14



AAR Detachable Carrying Handle-BK
AAR 提把組 - 黑色
MH-16



AAR Handguard-BK
AAR 戰術護木組 - 黑色
MH-22

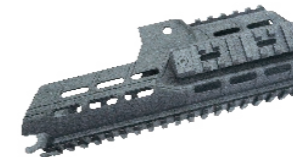

AAR SFS Stock-BK
AAR 狙擊折疊托組 - 黑色
MH-23



AARF Lightweight Folding Stock
AARF 輕量化折疊托 - 黑色
MH-35



SFS Stock Patents acquired: D137321 / ZL201030002113.8



Tan & Two-Tone Series 沙色 & 雙色版

AAR Lower Receiver-TAN
AAR 下槍身 - 沙色
MH-27



AAR Magazine Housing Assembly-TAN
AAR 槍身下蓋 - 沙色
MH-26



AAR Upper Receiver-TAN
AAR 上槍身組 - 沙色
MH-29



AAR Charging Handle Set-TAN
AAR 槍機拉柄組 - 沙色
MH-30



AAR Detachable Carrying Handle-TAN
AAR 提把組 - 沙色
MH-28



AAR Handguard-TAN
AAR 戰術護木組 - 沙色
MH-24



AAR SFS Stock-TAN
AAR 狙擊折疊托組 - 沙色
MH-25



AARF Lightweight Folding Stock-TAN
AARF 輕量化折疊托 - 沙色
MH-36



AARF Lightweight Folding Stock-Two-Tone
AARF 輕量化折疊托 - 雙色
MH-37



CES SERIES



With the latest kits of flash hider, tactical handguard and folding stock etc. combined into the classic CES, ICS creates a brand new modern combat system - CES-MRS. The modular rail system allows multi-kits equipment with invincible performance at battlefield.

Patents acquired: D 137321 / D 168400 / M 351340 / M 320468 / ZL 200820137077.3 / ZL 201030002113.8 / 002527580-0001



CES A / SD SERIES

警用 / 衝鋒槍 -A 系列 /SD 系列「現代版」



ICS-01 SD5 Proline
Fixed Stock / 現代固定托



ICS-02 SD6 Retractable Stock / 現代伸縮托



ICS-03 A4 Fixed Stock / 現代固定托



ICS-04 A5 Retractable Stock / 現代伸縮托



	ICS-01	ICS-02	ICS-03	ICS-04
Length/Retractable	780 (mm)	740.5/600 (mm)	680 (mm)	640/500 (mm)
Barrel length (mm)	230	230	230	230
Muzzle velocity	112-122 m/s (367-400 FPS) ※	112-122 m/s (367-400 FPS) ※	112-122 m/s (367-400 FPS) ※	112-122 m/s (367-400 FPS) ※
Weight (g)	2240	2300	2300	2000
Battery type	9.6V Ni-Mh or 11.1V Li-Po	9.6V Ni-Mh or 11.1V Li-Po	8.4V Ni-Mh or 11.1V Li-Po	8.4V Ni-Mh or 11.1V Li-Po
Connector size	Small connector	Small connector	Small connector	Small connector

※ NOTE:
 1. The product specification is for reference only and may be subject to change.
 2. Battery type is recommended, not included.
 3. For AEG with M100 spring, it is recommended to use voltage 7.4V Li-Po or 9.6V Ni-Mh batteries.
 4. Muzzle velocity is measured with 0.20g BB's, and is adjusted to comply with market regulation/ requirements for specific countries as shown below:
 Below 106 m/s (350 FPS): Belgium, France, Netherlands, Portugal, Spain, UK
 Below 100 m/s (328 FPS): Italy
 Below 95 m/s (312 FPS): Japan
 Below 45 m/s (148 FPS): Korea

CES / CES-P Compatible Parts

Suppressor 減音管

CES SD Suppressor
CES SD 減音管
MP-07



CES SD Suppressor
CES SD 減音管
MP-66



(CCW 14mm)
(14mm 逆牙)

CES Flash Suppressor Adapter
CES 防火帽轉接頭
MP-59



(CCW 14mm)
(14mm 逆牙)

CES SD Suppressor Adapter
CES SD 減音管轉接頭
MP-78



CES Gearbox 齒輪箱

CES Gearbox I
CES 齒輪箱 I
MC-51



CES Fire Selector Lever
CES 現代型射擊選擇鈕
MP-02



CES Gearbox II
CES 齒輪箱 II
MC-52



CES H-UP Set
CES H-UP 組
MP-22



CES Gearbox III
CES 齒輪箱 III
MC-53



CES Barrel Bracket Set (For Floating Hop Up)
CES 槍管固定座 (浮動式 H-UP 用)
MP-133



CES Gearbox Complete Set
CES 齒輪箱完成品
MC-62



CES Gearbox Shell
CES 空齒輪箱
MC-63



Tactical Rail 軌道

CES A Series Tactical Rail (21x114mm)
CES A 系列戰術軌道條 (21x114mm)
MP-54



CES SD Tactical Rail (Long, 21x183mm)
CES SD 戰術軌道條 (長, 21x183mm)
MP-65



PDW Tactical Rail Set (21x125mm)
PDW 戰術軌道條 (21x125mm)
MP-68



CES Tactical Rail (21x50mm)
CES 戰術軌道條 (21x50mm)
MP-73



CES Tactical Mount
CES 戰術軌道固定座
MP-55



CES High Tactical Mount
CES 戰術軌道加高座
MP-56



CES High Tactical Mount Set
CES 戰術軌道加高座組
MP-61



CES Tactical Rail Clips (4pcs)
CES 戰術軌道條夾片 (4入)
MP-72



背帶扣環 Brace Cramp

CES A Series Brace Cramp Ring
CES A 系列前視孔槍背帶扣環
MP-40



CES SD Series Brace Cramp Ring
CES SD 前視孔槍背帶扣環
MP-50



CES Sling Bracket
CES 槍背帶扣片
MP-36



CES Inner Barrel Bracket
CES 槍管固定環
MP-32

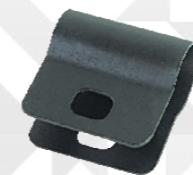

CES A Series Laser Cap
CES A 系列雷射前蓋
MP-75



CES Cocking Handle Spring
CES 拉柄彈簧
MP-44



G3 Cut-Off Lever
G3 單連發選擇片
MP-26



CES Cocking Handle Spring Guide
CES 槍機複進彈簧導桿
MP-33



CES Cut-Off Lever-Early Ver.
CES 早期型射擊選擇片
MP-47

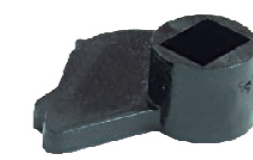

Cleaning Rod
通槍條
MP-39



CES/CS4 Safety Cover
CES/CS4 保險擋片
MP-24



CES Switch Plate
CES 電閘開關片
MP-25



CES/CS4 Nozzle
CES/CS4 推彈套筒
MP-23



Receiver Set / Housing

槍身組 / 握把



CES Metal Receiver (Aluminum)
CES 金屬槍身 (鋁製)
MP-41



CES Modern Lower Housing
CES 現代型握把
MP-42



CES Plastic Receiver Set (Sportline)
CES 塑膠槍身 (運動版)
MP-79



CES Modern Metal Receiver Set
CES 現代型金屬槍身組
MP-28



MS1 Lower Housing-Modern Ver.
MS1 現代型握把
MP-125

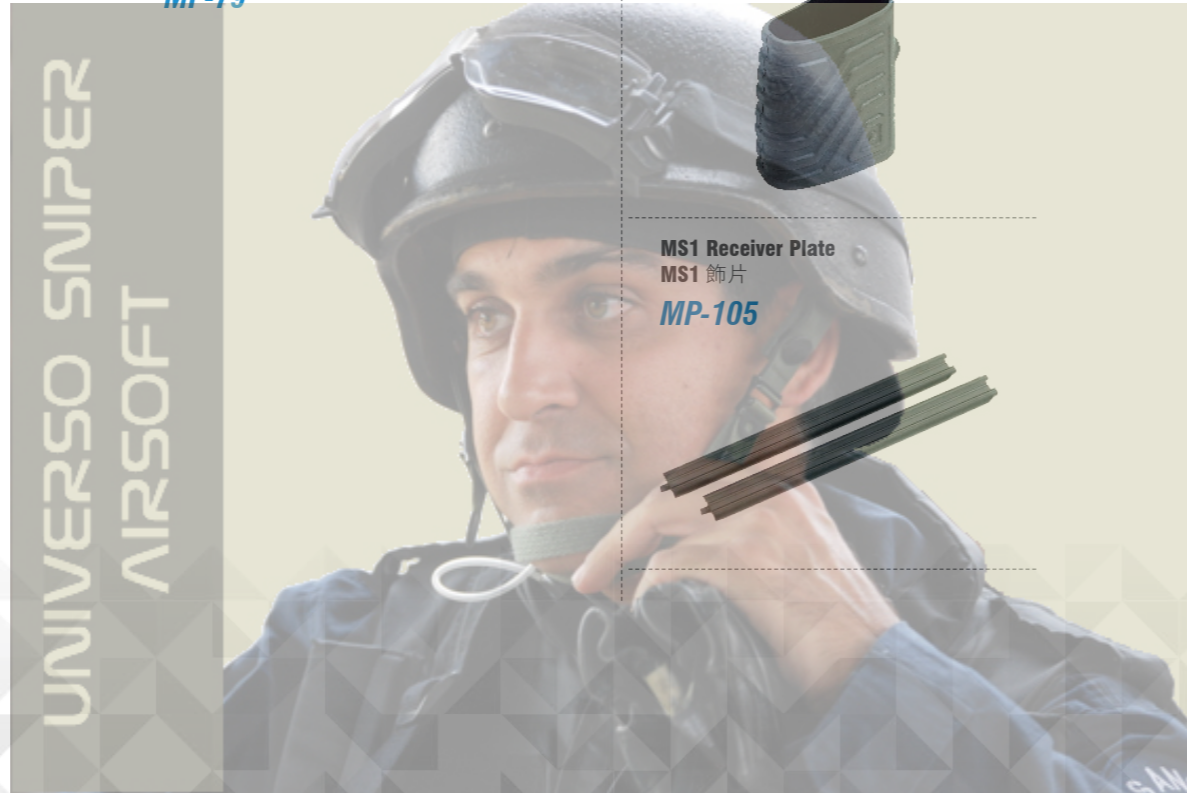

CES Metal Receiver Cap
CES 槍身上蓋音管
MP-76



MS1 Grip Suit
MS1 握把套
MP-102



MS1 Receiver Plate
MS1 飾片
MP-105



Tactical Handguard

戰術護木

CES Tactical Flash Light Handguard With Flash Light-BK
CES 槍燈護木 - 黑色
MP-147



CES Tactical Flash Light Handguard With Flash Light-TAN
CES 槍燈護木 - 沙色
MP-148



CES Tactical Flash Light Handguard-BK (W/O Flash Light)
CES 槍燈護木 - 黑色 (不含槍燈)
MP-149



CES Tactical Flash Light Handguard-TAN (W/O Flash Light)
CES 槍燈護木 - 沙色 (不含槍燈)
MP-150



CES Tactical Flash Light
CES 槍燈
MP-146



Tactical Foregrip
戰術握把
MP-53



CES A Tactical Handguard Set
CES A 系列戰術護木組
MP-52



CES SD Tactical Handguard Set
CES SD 戰術護木組
MP-64



CES/CES-P A Series Handguard
CES/CES-P A 系列三角護木
MP-15



CES/CES-P A Series Tactical Handguard
CES/CES-P A 系列戰術護木
MP-115



Tactical Foregrip
戰術握把
MP-134



CES SD Handguard
CES SD 下護木
MP-09



CES SD Handguard Holder
CES SD 護木固定架
MP-10



CES Handguard Holder O-Ring
CES 護木固定銷墊片
MP-11



CES Handguard Locking Pin
CES 護木固定銷
MP-12



CES Handguard Pin
CES 三角護木插銷
MP-19



Receiver Set / Housing

槍身組 / 握把

CES Metal Magazine (230 Rounds)
CES 金屬彈匣 (230 發)

MP-30 1 入裝 / 1pcs/box
MP-126 6 入裝 / 6pcs/box



CES Magazine Clamp
CES 彈匣連結器

MP-05



CES Magazine Spring
CES 彈匣彈簧片

MP-29



CES Magazine Catch Button Set
CES 彈匣卡榫組

MP-03



CES Magazine Catch Sleeve
CES 彈匣卡榫套筒

MP-34



拉柄組 Handle Set

CES A Series Metal Cocking Handle Set
CES A 系列金屬拉柄組

MP-27



CES A Series Plastic Cocking Handle Set (Sportline)
CES A 系列塑膠拉柄組 (運動版)

MP-80

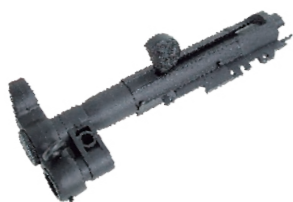

CES SD Metal Cocking Handle Assembly
CES SD 金屬拉柄組

MP-08



MS1 Charging Handle
MS1 拉柄頭

MP-92



CES/CES-P Cocking Lever
CES/CES-P 拉柄頭

MP-57



覘孔 / 準星 Sight Set

CES SD Front Sight Assembly
CES SD 前覘孔座

MP-20



CES A Series Front Sight
CES A 系列前覘孔座

MP-51



MS1 Rear Sight Set
MS1 覘孔組

MP-104



MS1 Front Sight Set
MS1 準星座組

MP-112



MS1 Front Sight Post
MS1 準星

MP-113



Stock

後托

Sopmod Stock With CES Adapter-BK
CES 海豹托 - 黑色

MP-127



Sopmod Stock With CES Adapter-TAN
CES 海豹托 - 沙色

MP-128



Retractable Stock With CS4 Adapter-BK
CES 戰術伸縮托 - 黑色

MP-129



CES Stock Adapter
CES 伸縮托套件組

MP-131



CES/CES-P Fixed Stock
CES/CES-P 固定托

MP-17



CES/CES-P Fixed Stock (Incl. Power Cord Set)
CES/CES-P 固定托 (含線材)

MP-48



CES Short Fixed Stock
CES 固定短托

MP-124



CES Folding Stock
CES 折疊托

MP-71



CES Retractable Stock (Incl. Block Set)
CES 伸縮托 (含擋片)

MP-87



CES Butt Pad
CES 固定托底板

MP-06



CES Sling Mount End Cap
CES 機匣尾蓋

MP-74



CES Battery Power Cord Set for Fixed Stock
CES 固定托線材組

MP-38

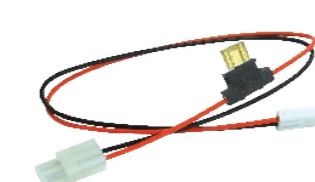

CES Stock Pin
CES 槍機箱結合銷

MP-01



CES Stock Retract Lever Set
CES 伸縮托旋轉卡榫

MP-04



馬達組 Motor

CES Retractable Stock Block Set
CES 伸縮托擋片

MP-21



CES Receiver End Cap
CES 槍身後蓋

MP-81

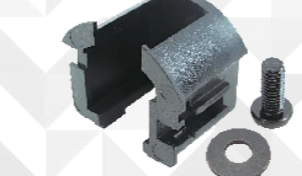

CES Heat Radition Motor Butt Plate
CES 馬達散熱底板

MP-43



CES Motor Spacer
CES 馬達墊片

MP-35



CES-P Proprietary Parts

此頁為 CES-P 專用零件，和一般 CES 槍型不相容

CES-P Lower Gearbox
CES-P 下齒輪箱

MP-120



CES-P Fire Select Slice
CES-P 單連發選擇片

MP-98



CES-P Ejection Port Cover Set
CES-P 槍機護蓋組

MP-91



MRS CES-P Tactical Handguard
MRS CES-P 戰術護木

MP-116



CES/CES-P Rear Sight Set
CES/CES-P 覘孔組

MP-31



CES-P Front Sight Post
CES-P 準星

MP-110



CES-P Front Sight Set
CES-P 準星座組

MP-111



CES-P Stamped Steel Upper Receiver
CES-P 鍍金槍身

MP-106



CES-P Motor Shell
CES-P 馬達座組

MP-123

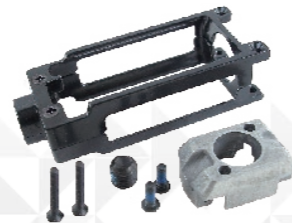

CES-P Magazine Catch Set
CES-P 彈匣卡榫組

MP-108



CES-P Reinforced Outer Barrel
CES-P 槍管

MP-107



CES-P Heat Radition Motor Butt Plate
CES-P 馬達散熱底蓋

MP-103



CES-P Charging Handle Set
CES-P 拉柄組

MP-93



CES-P Receiver Pin
CES-P 槍身固定銷

MP-90



CES-P Retractable Stock
CES-P 伸縮托

MP-89



CES-P SFS Stock
CES-P SFS 狙擊折疊托

MP-88



CES-P Lower Housing-Modern Ver.
CES-P 現代型握把

MP-101



MP-94 CES-P Upper Gearbox Block
CES-P 上齒輪箱擋塊

MP-95 CES-P Upper Gearbox
CES-P 上齒輪箱

MP-96 CES-P H-UP Set
CES-P H-UP 組

MP-97 CES-P H-UP Spring
CES-P H-UP 彈簧

MP-99 CES-P Fire Selector
CES-P 現代型射擊選擇鈕

MP-100 MS1 Fire Selector
MS1 現代型射擊選擇鈕

MP-109 CES-P Power Cord Set
CES-P 電線組

MP-117 CES-P Fire Select Panel
CES-P 單連發選擇板

MP-118 CES-P Electric Controller
CES-P 電子控制器

MP-119 CES-P Fire Rounds Controller
CES-P 時間調整控制器

MP-121 CES-P Lower Electric Socket
CES-P 下接電組

MP-122 CES-P Spring Tension Release Lever
CES-P 釋放撥桿

MP-132 CES/CS4 Gearbox Clip (Incl. Spring)
CES/CS4 齒輪箱固定扣 (含彈簧)



MGL

Multiple Grenade Launcher SERIES



Patents acquired:
US 8,707,939 B2 / M 420677 / M 422666 / EP 2573503A1 / EP2573499A1



The ICS-190 is made 1:1 in scale and detailing to a real MGL replica. The ICS MGL faithfully presents the feature of the MGL's doughty looking: ealistic revolver, the tube, the handguard rail and the revolver latch. Besides, the ICS MGL operates exactly like the real firearm.



Milkor, (PTY) Ltd., South Africa, and the milkor logo are registered trademarks of Milkor (PTY) Ltd., South Africa - www.milkor.co.za - and are used for airsoft replicas under license from ActionSportGames A/S, Denmark - www.actionsportgames.com.

Milkor 是 Milkor (PTY) Ltd., South Africa 的註冊商標。在電動槍產品類別，是由 ActionSportGames A/S, Denmark 授權使用。



MGL METAL RAIL HANDGUARD

多管榴彈發射器 - 鈹金護木版

Upgrade version of MGL! Compatible with TAG Grenade and other rubber projectile body. Quality material and advanced design promote MGL to a new level and breakthrough airsoft tradition.

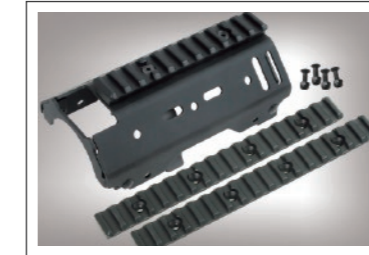

MGL Metal Lower Handguard (Short Version MM-42)

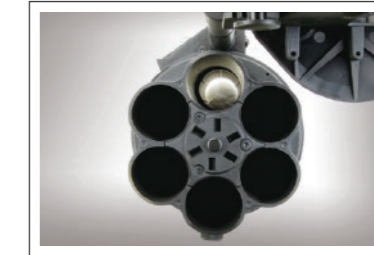

The peration is same as in real steel



Adjust 6 Lengths and 3 Angles Stock

ICS-193 MGL S | Proline

Retractable Stock / 伸縮托 鈹金護木短版

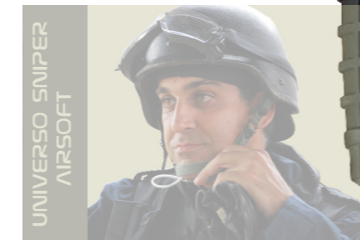

ICS-193	
Length/Retractable	725/630
Barrel length	200
Weight (g)	2400
Caliber	40 mm
Grenade capacity	6 rounds
Material	Engineering plastic
Handguard type	Metal

* Velocity varies according to different gas pressure and grenade

MGL METAL RAIL HANDGUARD

多管榴彈發射器 - 鍍金護木版

- Upgrade version of MGL! Compatible with TAG Grenade and other rubber projectile body.
- Quality material and advanced design promote MGL to a new level and breakthrough airsoft tradition.

ICS-192 MGL L Proline

Retractable Stock / 伸縮托 鍍金護木長版

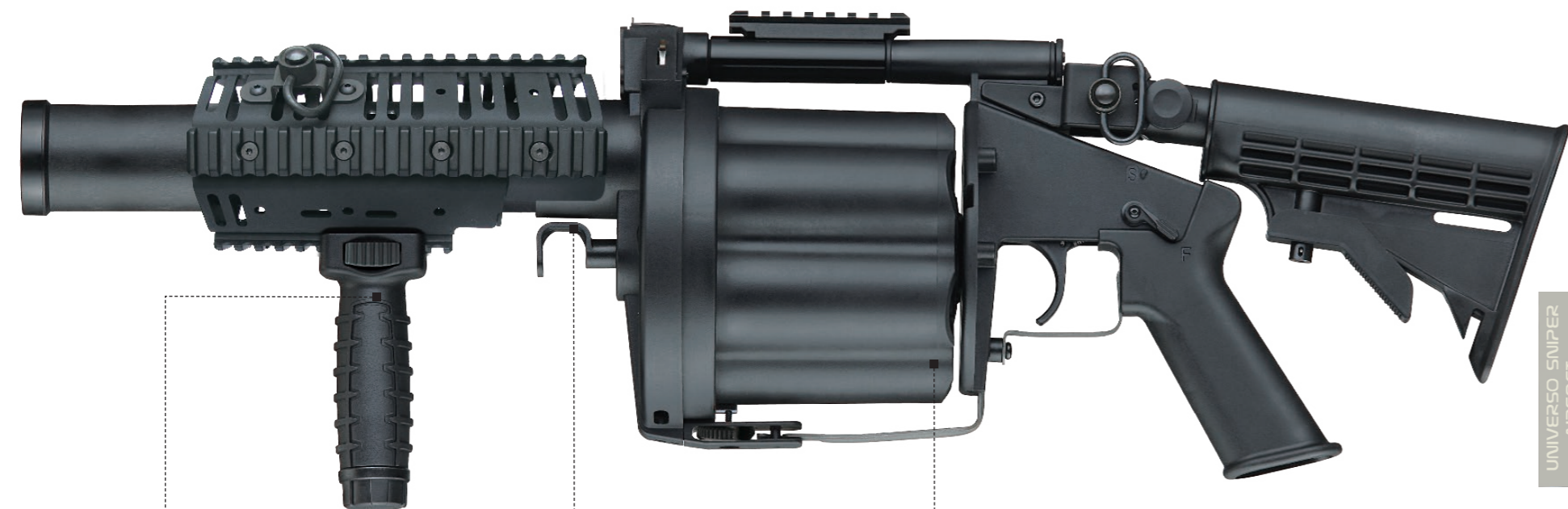

Install Pressure Switches



Reproduce the Revolver Latch



Load Six Grenades (MA-138 / MA-158)

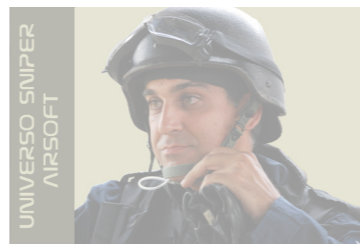

	ICS-192
Length/Retractable	825/725
Barrel length	295
Weight (g)	2700
Caliber	40 mm
Grenade capacity	6 rounds
Material	Engineering plastic
Handguard type	Metal

* Velocity varies according to different gas pressure and grenade

ICS-190 MGL Black

Retractable Stock / 伸縮托



ICS-191 MGL Tan

Crane Stock / 海豹托



	ICS-190	ICS-191
Length/Retractable	725/630 (mm)	780/675 (mm)
Barrel length	200	200
Weight (g)	2200	2200
Caliber	40 mm	40 mm
Grenade capacity	6 rounds	6 rounds
Material	Engineering plastic	Engineering plastic
Handguard type	Engineering plastic	Engineering plastic

* Velocity varies according to different gas pressure and grenade

MGL Accessories

原廠零配件

MGL Upper Handguard-BK
MGL 上護木組 - 黑色
MM-20



MGL Lower Handguard-BK
MGL 下護木組 - 黑色
MM-22



MGL Metal Upper Handguard
MGL 金屬上護木組
MM-39

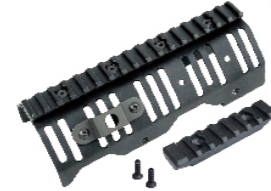

MGL Metal Lower Handguard
MGL 長管金屬下護木組
MM-40



(Long Version)

MGL Metal Lower Handguard
MGL 短管金屬下護木組
MM-42



(Short Version)

ICS Tactical Foregrip-BK
ICS 快拆戰術握把 - 黑色
MM-23



MGL Upper Handguard-TAN
MGL 上護木組 - 沙色
MM-37



MGL Lower Handguard-TAN
MGL 下護木組 - 沙色
MM-38

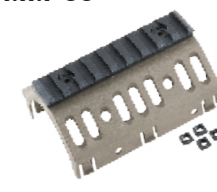

MGL Tube
MGL 槍管組
MM-21



MGL Tube (Long Version)
MGL 長槍管組
MM-41



MGL Stock Tube
MGL 槍托管組
MM-02



ICS Tactical Foregrip-TAN
ICS 快拆戰術握把 - 沙色
MM-24



MGL Fire Selector-BK
MGL 射擊選擇鈕組 - 黑色
MM-03



MGL Hammer Assembly-BK
MGL 擊發底板組 - 黑色
MM-05



MGL Trigger Guard-BK
MGL 護弓組 - 黑色
MM-06



MGL Revolver Plate-BK
MGL 槍身底板組 - 黑色
MM-07



MGL Revolver Cover Set-BK
MGL 槍身前段組 - 黑色
MM-19



MGL Receiver Connector Set-BK
MGL 槍身連接管組 - 黑色
MM-08



MGL Fire Selector-TAN
MGL 射擊選擇鈕組 - 沙色
MM-26



MGL Hammer Assembly-TAN
MGL 擊發底板組 - 沙色
MM-27



MGL Trigger Guard-TAN
MGL 護弓組 - 沙色
MM-28



MGL Revolver Plate-TAN
MGL 槍身底板組 - 沙色
MM-29



MGL Revolver Cover Set-TAN
MGL 槍身前段組 - 沙色
MM-36



MGL Receiver Connector Set-TAN
MGL 槍身連接管組 - 沙色
MM-30



MGL Receiver Set (Rear Part)-BK
MGL 槍身後段組 - 黑色
MM-10



MGL Revolver-BK
MGL 彈輪組 - 黑色
MM-11



MGL Body Hook-BK
MGL 槍身定位扣組 - 黑色
MM-15



MGL Body Latch-BK
MGL 槍身釋放柄組 - 黑色
MM-16



MGL Upper Cover-BK
MGL 槍身上蓋組 - 黑色
MM-17

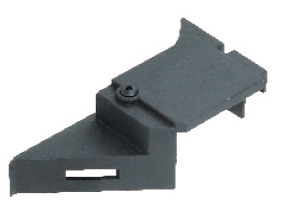

MGL Trigger Set
MGL 扳機組
MM-04



MGL Receiver Set (Rear Part)-TAN
MGL 槍身後段組 - 沙色
MM-31



MGL Revolver-TAN
MGL 彈輪組 - 沙色
MM-32



MGL Body Hook-TAN
MGL 槍身定位扣組 - 沙色
MM-33



MGL Body Latch-TAN
MGL 槍身釋放柄組 - 沙色
MM-34



MGL Upper Cover-TAN
MGL 槍身上蓋組
MM-35



MGL Body Connector
MGL 槍身連動桿
MM-09



MGL Spring Housing
MGL 板簧組
MM-12



MGL Spring Housing Set
MGL 彈輪驅動元件組
MM-13



MGL Revolver Axle
MGL 彈輪心軸
MM-14



40mm Lightweight Grenade

輕量化榴彈

M203 Grenade Launcher
M203 榴彈發射器
MA-159



(One 40mm Lightweight Grenade Incl.)
(含 40mm 輕量化榴彈 *1)

M203 Grenade Launcher
M203 榴彈發射器
MA-339



MGL Fire Selector-TAN
MGL 射擊選擇鈕組 - 沙色
MM-26



MGL Hammer Assembly-TAN
MGL 擊發底板組 - 沙色
MM-27



MGL Trigger Guard-TAN
MGL 護弓組 - 沙色
MM-28



MGL Revolver Plate-TAN
MGL 槍身底板組 - 沙色
MM-29



MGL Revolver Cover Set-TAN
MGL 槍身前段組 - 沙色
MM-36



MGL Receiver Connector Set-TAN
MGL 槍身連接管組 - 沙色
MM-30



MGL Revolver Latch
MGL 彈輪釋放柄組
MM-18



MGL Revolver Hook
MGL 槍身固定扣
MM-43



40mm Lightweight Grenade (2pcs)
40mm 輕量化榴彈 (2 入)
MA-138



40mm Lightweight Grenade (6pcs/Box)
40mm 輕量化榴彈 (6 入)
MA-158



Lightweight Grenade Cap (6pcs/Set)
輕量化榴彈頭 (6 入)
MA-166



TOD

沙漠之虎 SERIES



ARM 輕機槍

ICS-91 TOD ARM Proline Folding Stock / 折疊托 金屬版

The ICS TOD series rifles are the worthy collection of classic and practical rifles that reproduce the real gun design. Its fire select lever on right side and grip selector manual act simultaneously. Players can adjust fire mode to safety, semi-auto and full auto without changing their firing posture.

	ICS-91	
Length/Retractable	980/750 (mm)	
Barrel length (mm)	515	
Muzzle velocity	117-138 m/s (385-453 FPS) ※	
Weight (g)	3500	
Battery type	9.6V Ni-Mh or 11.1V Li-Po	
Connector size	Small connector	
Mag. capacity	400	
Spring	M120	
Material	Full metal	
Motor axle	Short	

UNIVERSO SNIPER AIRSOFT



Quick released foldable bi-pod

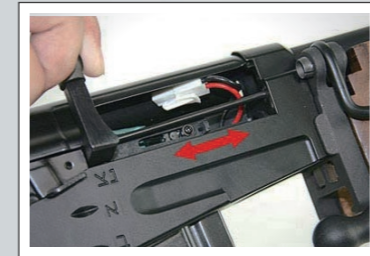

Reproduce the movable components of the real gun



Battery type : 9.6V Ni-Mh or 11.1V Li-Po



The real action side grip selector



Folding stock (MG-32)



ICS-91 TOD ARM Proline
Folding Stock / 折疊托 金屬版



Accurate steel dewaxing process

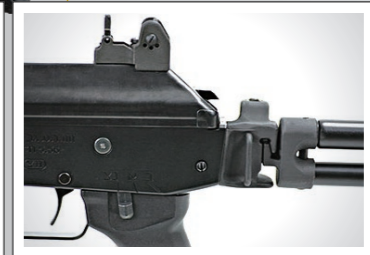

IDF Hebrew engraving

TOD MRS 戰術版

以色列軍事工業局 IMI 設計的經典槍款 - 加利步槍 - 戰術版



Adjustable cheek rest



MRS tactical module rail system

ICS-96 TOD MRS Proline
Folding Stock / 折疊托 金屬版



Ergonomic design
newly developed for tactical grip



Folding stock

ICS-96	
Length/Retractable	980/750 (mm)
Barrel length (mm)	515
Muzzle velocity	117-138 m/s (385-453 FPS) ※
Weight (g)	3860
Battery type	9.6V Ni-Mh or 11.1V Li-Po
Connector size	Small connector
Mag. capacity	400
Spring	M120
Material	Full metal
Motor axle	Short



Tactical handguard

TOD AR 步槍



ICS-92 TOD AR Proline
Folding Stock / 折疊托 金屬版



ICS-92	
Length/Retractable	980/750 (mm)
Barrel length (mm)	515
Muzzle velocity	117-138 m/s (385-453 FPS) ※
Weight (g)	3000
Battery type	9.6V Ni-Mh or 11.1V Li-Po
Connector size	Small connector
Mag. capacity	400
Spring	M120
Material	Full metal
Motor axle	Short

※ NOTE:

1. The product specification is for reference only and may be subject to change.
2. Battery type is recommended, not included.
3. For AEG with M100 spring, it is recommended to use voltage 7.4V Li-Po or 9.6V Ni-Mh batteries.
4. Muzzle velocity is measured with 0.20g BB's, and is adjusted to comply with market regulation/requirements for specific countries as shown below:
 Below 106 m/s (350 FPS): Belgium, France, Netherlands, Portugal, Spain, UK
 Below 100 m/s (328 FPS): Italy
 Below 95 m/s (312 FPS): Japan
 Below 45 m/s (148 FPS): Korea

TOD SERIES Compatible Parts

TOD 共用零件

TOD Hi-Cap Metal Magazine (400 Rounds)
TOD 高容量金屬彈匣 (400 發)

MG-23 1 入裝 / 1pc
MG-39 6 入裝 / 6pcs/box



TOD Pistol Grip
TOD 握把
MG-26



TOD Tactical Pistol Grip
TOD 戰術握把
MG-38



TOD Cheek Rest Set
TOD 貼腮組
MG-37



TOD Selector Plate
TOD 射擊選擇片
MG-40



TOD ARM Bipod Set
TOD ARM 腳架組
MG-15



TOD H-up Set
TOD H-up 組
MG-24



TOD Charging Handle Set
TOD 槍機拉柄組
MG-31



TOD/MAR Nozzle
TOD/MAR 推彈套筒
MG-17



TOD Gearbox Assembly
TOD 齒輪箱組
MG-25



TOD MRS Upper Housing Assembly
TOD MRS 上機匣組
MG-35



TOD Reinforced Outer Barrel Set
TOD 槍管組
MG-22



TOD Receiver Set
TOD 槍身組
MG-28



TOD Folding Stock Set
TOD 折疊托組
MG-32



Handguard 護木

TOD ARM Handguard Set
TOD ARM 護木組
MG-13



TOD Handguard Fornt Frame
TOD 前護木框組
MG-21



TOD ARM Flash Hider
TOD ARM 防火帽
MG-11



TOD AR Handguard Set
TOD AR 護木組
MG-18



TOD Front Sight Assembly
TOD 準星組
MG-12



TOD AR Flash Hider
TOD AR 防火帽
MG-16



TOD Tactical Handguard
TOD 戰術護木
MG-36



TOD Upper Housing Assembly
TOD 上機匣組
MG-27



TOD Gas Tube Set
TOD 瓦斯鋼管組
MG-20



TOD ARM Handguard Rear Frame With Handle
TOD ARM 後護木框組
MG-14



Fire Selector Lever 射擊選擇組

TOD Fire Selector Lever
TOD 射擊選擇組
MG-29



TOD AR Handguard Rear Frame
TOD AR 後護木框組
MG-19



TOD Grip Fire Selector Lever
TOD 左射擊選擇組
MG-30



Flash Hider 防火帽

Gas Tube Set 瓦斯鋼管組

TOD Gas Tube Set (Enlarged)
TOD 瓦斯鋼管組 (加大)
MG-33



TOD Tactical Rail Gas Tube Set
TOD 戰術軌道型瓦斯鋼管
MG-34



Compatible Parts

Piston 活塞

Original Piston
塑膠活塞
MC-01



Aluminum Piston (Full Teeth)
鋁活塞 (全齒)
MC-05



Aluminum Piston (Half Teeth)
鋁活塞 (半齒)
MC-06



Original Piston Set
塑膠活塞組
MC-95



Reinforced Upgrade
POM Piston Set
升級強化活塞組
MC-169



Reinforced Upgrade POM Piston
升級強化活塞
MC-170



(Incl. Slice)

Reinforced Upgrade POM Piston
升級強化活塞
MC-172



(W/O Slice)
(不含鋼片)

High Torque Piston Set
半齒活塞組
MC-213



High Torque Piston
半齒活塞
MC-214



High Torque Piston
半齒活塞
MC-215



(W/O Slice)
(不含鋼片)

EBB Reinforced POM Piston
EBB 塑鋼活塞
MC-221



(W/O Slice)
(不含鋼片)

EBB Reinforced POM Piston Set
EBB 塑鋼活塞組
MC-222



EBB Reinforced POM Piston
EBB 塑鋼活塞
MC-223



(W/ Slice)
(含鋼片)

8 Holes Silent Piston Set
八孔吸排氣頭活塞組
MC-122



Reinforced Upgrade Piston Slice
升級強化活塞鋼片
MC-171



High Torque Piston Slice
半齒活塞鋼片
MC-216



Piston Slice
活塞鋼片
MC-10



Cylinder 氣缸

Original Cylinder (4 Holes)
氣缸 (開四孔: 原廠)
MC-57



Oversized Cylinder (4 Holes)
氣缸 (開四孔: 加大)
MC-58



Full Capacity Oversized Cylinder
全氣量加大氣缸
MC-71



Full Capacity Cylinder
全氣量氣缸
MC-72



Piston Head (Plastic)
氣缸頭 (塑膠)
MC-19



APE/AAR Cylinder Head
APE/AAR 氣缸頭
MC-236



Aluminum Cylinder & Piston Head Set (Oversized)
鋁活塞頭組 (加大)
MC-56



Aluminum Cylinder Head (Oversized)
氣缸頭 (加大)
MC-91



Piston Head (Oversized)
活塞頭 (加大)
MC-93



8 Holes Silent Piston Head
八孔吸排氣頭
MC-121



H-up Bucking
含彈橡皮
MC-16



H-up Spacer
H-up 緩衝膠圈
MC-17



Ver.2 Tappet Plate
撥彈連桿
MC-02



CES Selector Plate
CES 射擊選擇片
MC-04



CS4/CES Cut-off Lever
CS4/CES 單連發控制桿
MC-20



CES Trigger
CES 扳機
MC-64



CES Switch Assembly
CES 電閘線材
MC-15



Connector (Large Male To Small Female)
轉接頭 (大公轉小母)
MC-47



Connector (Large Female To Small Male)
轉接頭 (大母轉小公)
MC-48



30A Fuse
30A 保險絲
MC-83



Mini Blade Fuse-30A (5pcs)
微型保險絲 -30A (5 入)
MC-211

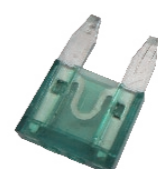

Mini Blade Fuse-20A (5pcs)
微型保險絲 -20A (5 入)
MC-230

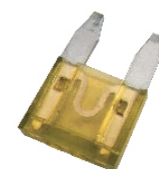

Mini Blade Fuse-25A (5pcs)
微型保險絲 -25A (5 入)
MC-240



CS4/CES Switch Unit
CS4/CES 電閘
MC-237



(W/O Cable)
(不含線材)

Ver.2 Metal Spring Guide
二代尾頂桿
MC-43



Ver.3 Metal Spring Guide
三代尾頂桿
MC-44



Plastic Spring Guide
塑膠尾頂桿
MC-66



CES/MAR Anti-Reversal Latch
CES/MAR 止逆轉組
MC-60



Spring Set
彈簧組
MC-65



Tappet Plate Gear Cam
上彈偏心軸
MC-102



BB Loader
BB 彈填彈器
MC-185



CES/CS4 Nozzle
CES/CS4 推彈套筒
MP-23



CES Motor Spacer
CES 馬達墊片
MP-35



Cleaning Rod
通槍條
MP-39



Tactical Foregrip
戰術握把
MP-53



Tactical Foregrip
戰術握把
MP-134



Flash Hider

防火帽系列

CXP

CXP-08 Flash Hider
CXP-08 防火帽
MA-96



UK1 Flash Hider
UK1 防火帽
MA-219



UK1 Plastic Red Flash Hider
UK1 塑膠紅頭防火帽
MA-327



Raider Flash Hider
突擊兵防火帽
MA-331



Crown Flash Hider
鋼製皇冠防火帽
MA-356



L85/L86

L85 Flash Hider
L85 防火帽
ML-03



L86 Flash Hider
L86 防火帽
ML-19



CS4

CS4/CS16 Birdcage Flash Hider
CS4/CS16 制式防火帽
MA-02



C15 Flash Hider
C15 防火帽
MA-03



CS4 Plastic Red Flash Hider
CS4 塑膠紅頭防火帽
MA-326



MAR

MAR/MARM Flash Hider
MAR/MARM 防火帽
MK-08



MAR SU Flash Hider
MAR SU 防火帽
MK-63



AAR

AAR Flash Hider
AAR 防火帽
MH-21



AAR Plastic Red Flash Hider
AAR 塑膠紅頭防火帽
MH-38



OTHER

TOD ARM Flash Hider
TOD ARM 防火帽
MG-11



TOD AR Flash Hider
TOD AR 防火帽
MG-16



CES/CES-P Metal Flash Hider
CES/CES-P 金屬防火帽
MP-16



CES/CES-P Vortex Flash Hider
CES/CES-P 五叉防火帽
MP-58



CES Vortex Flash Hider Set
CES 五叉防火帽
MP-62



CES Threaded Claw Flash Hider
CES 三爪防火帽
MP-67



MS1 Flash Hider
MS1 防火帽
MP-114



CES Plastic Red Hider
CES 塑膠紅頭防火帽
MP-151

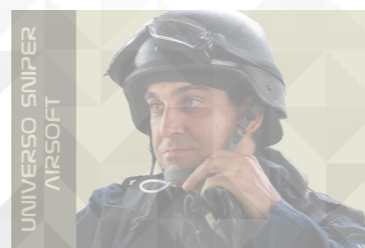

Gear Series

齒輪系列

Bevel Gear (No.1)
1 號齒輪
MC-07



Bevel Gear (No.2)
2 號齒輪
MC-08



Bevel Gear (No.3)
3 號齒輪
MC-09



Original Gear Set
原廠齒輪組 (粉末冶金 1 號齒)
MC-14



Motor Gear (PM)
馬達傘齒 (粉末冶金)
MC-101



Bevel Gear (MIM)
1 號齒輪 (粉末射出)
MC-218



Pinion Gear (MIM)
馬達傘齒 (粉末射出)
MC-219



Original Gear Set (MIM Bevel Gear)
原廠齒輪組 (粉末射出 1 號齒)
MC-238



Motor Series

馬達系列

Infinite motor & Super power Motor

Infinite Motor (Long)
無限長軸馬達

MC-161



Infinite Motor (Medium)
無限中軸馬達

MC-160



Infinite Motor (Short)
無限短軸馬達

MC-168



Super Power Motor (Long)
Super Power 長軸馬達

MC-217



Super Power Motor (Medium)
Super Power 中軸馬達

MC-228



Super Power Motor (Short)
Super Power 短軸馬達

MC-227



Turbo 3000 Motor

Turbo 3000 Motor (Long)
Turbo 3000 長軸馬達

MC-220



Turbo 3000 Motor (Medium)
Turbo 3000 中軸馬達

MC-226



Turbo 3000 Motor (Short)
Turbo 3000 短軸馬達

MC-225



Others 其他

Plastic Bushing Set-6mm
塑膠齒輪襯套組 -6mm
MC-11



Gear Spacer
齒輪墊片
MC-67



Spring Guide Bearing
尾頂桿止推軸承
MC-46



Metal Bushing Set
金屬齒輪襯套組
MC-03 (6mm)
MC-199 (7mm)
MC-200 (8mm)



Magazine Series

彈匣系列

Patents acquired: 002246579-0001 / USD7068805 / D159178

CS4, CXP, AAR, L85/L86 Series



T Tactical Magazine T 戰術彈匣

Black
黑色

T Tactical Hi-cap Magazine (300 Rounds)
T 戰術高容量彈匣 (300 發)
MA-186 1 入裝 / 1pc
MA-243 6 入裝 / 6pcs/box

Tan
沙色

T Tactical Hi-cap Magazine (300 Rounds)
T 戰術高容量彈匣 (300 發)
MA-240 1 入裝 / 1pc
MA-245 6 入裝 / 6pcs/box

- Medium capacity and silenced design satisfy players needs for quiet motion in the battlefield.
- Screwless design allows fast assembly / disassembly.
- Compatible with CS4, CXP, AAR and L85/86 series. Available for both single package and 6 pieces per box.

T Tactical Mid-cap Magazine (120 Rounds)
T 戰術靜音彈匣 (120 發)
MA-409 1 入裝 / 1pc
MA-413 6 入裝 / 6pcs/box

T Tactical Mid-cap Magazine (120 Rounds)
T 戰術靜音彈匣 (120 發)
MA-410 1 入裝 / 1pc
MA-414 6 入裝 / 6pcs/box

T Tactical Low-cap Magazine (45 Rounds)
T 戰術靜音彈匣 (45 發)
MA-187 1 入裝 / 1pc
MA-244 6 入裝 / 6pcs/box

T Tactical Low-cap Magazine (45 Rounds)
T 戰術靜音彈匣 (45 發)
MA-241 1 入裝 / 1pc
MA-246 6 入裝 / 6pcs/box



Metal Magazine 金屬彈匣

Black
黑色

Metal Hi-cap Magazine (450 Rounds)
金屬高容量彈匣 (450 發)
MA-04 1 入裝 / 1pc
MA-153 6 入裝 / 6pc

Tan
沙色

Metal Hi-cap Magazine (450 Rounds)
金屬高容量彈匣 (450 發)
MA-170 1 入裝 / 1pc

Metal Mid-cap Magazine (120 Rounds)
金屬靜音彈匣 (120 發)
MA-411 1 入裝 / 1pc
MA-415 6 入裝 / 6pcs/box

Metal Mid-cap Magazine (120 Rounds)
金屬靜音彈匣 (120 發)
MA-412 1 入裝 / 1pc
MA-416 6 入裝 / 6pcs/box

Metal Low-cap Magazine (45 Rounds)
金屬靜音彈匣 (45 發)
MA-152 1 入裝 / 1pc
MA-154 6 入裝 / 6pcs/box



Black
黑色

Metal Hi-cap short Magazine (170 rounds)
金屬高容量短彈匣 (170 發)
MA-352 1 入裝 / 1pc

*Not Compatible with L85/L86 series. * 不適用 L85/L86 系列



Canada C7 Magazine 加拿大 C7 彈匣

Black
黑色

Canada C7 Hi-cap Magazine (300 Rounds)
加拿大 C7 高容量彈匣 (300 發)
MA-92 1 入裝 / 1pc
MA-156 6 入裝 / 6pcs/box

Tan
沙色

Canada C7 Hi-cap Magazine (300 Rounds)
加拿大 C7 高容量彈匣 (300 發)
MA-171 1 入裝 / 1pc

CS4, CXP, AAR Series



T4 Tactical Magazine T4 戰術彈匣

*Not Compatible with L85/L86 series. * 不適用 L85/L86 系列

Black
黑色

T4 Tactical Hi-cap Magazine (300 Rounds)
T4 戰術高容量彈匣 (300 發)
MA-148 1 入裝 / 1pc
MA-150 6 入裝 / 6pcs/box

T4 Tactical Low-cap Magazine (45 Rounds)
T4 戰術靜音彈匣 (45 發)
MA-151 6 入裝 / 6pcs/box

Tan
沙色

T4 Tacatical Hi-cap Magazine (300 Rounds)
T4 戰術高容量彈匣 (300 發)
MA-328 6 入裝 / 6pcs/box

WWII Series

M3 Hi-cap Metal Magazine (430 Rounds)
M3 高容量彈匣 (430 發)

MY-19 1 入裝 / 1pc

M3 Low-cap Magazine (140 Rounds)
M3 靜音彈匣 (140 發)

MY-20 1 入裝 / 1pc



M1 Magazine (6mm, 42 Rounds)
M1 彈匣 (6mm, 42 發)

ME-01



M1 Magazine (8mm, 25 Rounds)
M1 彈匣 (8mm, 25 發)

ME-37



MAR Series

MAR Hi-cap Magazine (550 Rounds)
MAR 高容量彈匣 (550 發)

MK-01 1 入裝 / 1pc

MK-90 6 入裝 / 6pcs/box



TOD Series

TOD Hi-Cap Metal Magazine (400 Rounds)
TOD 高容量金屬彈匣 (400 發)

MG-23 1 入裝 / 1pc

MG-39 6 入裝 / 6pcs/box



CES Series

CES Metal Magazine (230 Rounds)
CES 金屬彈匣 (230 發)

MP-30 1 入裝 / 1pcs/box

MP-126 6 入裝 / 6pcs/box



Electric Drum Magazine

彈鼓系列

Patents acquired: M 453836

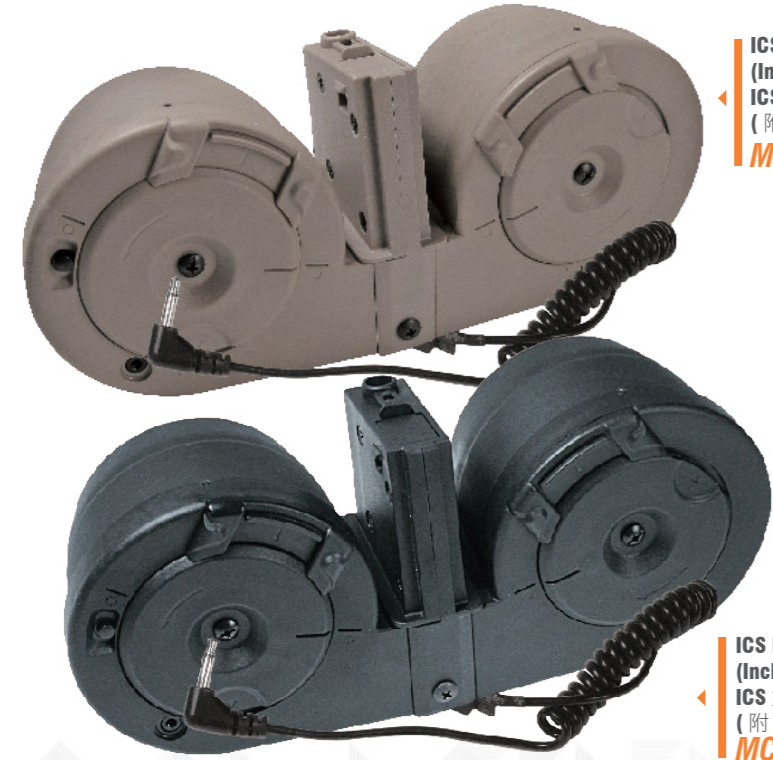

ICS Electric Drum Magazine-TAN
(Incl. CS4 Magazine Adaptor)
ICS 通用電動雙彈鼓 - 沙色
(附 CS4 彈匣接座)
MC-202

ICS Electric Drum Magazine-BK
(Incl. CS4 Magazine Adaptor)
ICS 通用電動雙彈鼓 - 黑色
(附 CS4 彈匣接座)
MC-201



NEW ICS Electric Drum Magazine-TAN
ICS 通用電動彈鼓 - 沙色
MC-241

NEW ICS Electric Drum Magazine-BLK
ICS 通用電動彈鼓 - 黑色
MC-239

Drum Magazine Pressure Switch
彈鼓觸碰式開關
MC-229

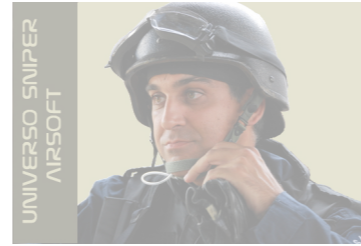

Magazine Adaptor 彈匣接座

CES Magazine Adaptor 彈匣接座		MAR / TOD Magazine Adaptor 彈匣接座		SG Magazine Adaptor 彈匣接座		CS4 / CXP Magazine Adaptor 彈匣接座	
MC-203 BK 黑色	MC-204 TAN 沙色	MC-205 BK 黑色	MC-206 TAN 沙色	MC-207 BK 黑色	MC-208 TAN 沙色	MC-209 BK 黑色	MC-210 TAN 沙色

Spring 彈簧

MC-231 M90	MC-41 M100	MC-39 M120	MC-37 M130	MC-38 M140	MC-42 M150	MC-45 M170
----------------------	----------------------	----------------------	----------------------	----------------------	----------------------	----------------------

Inner Barrel 內管

6.04mm



item#	length
MA-88	186 mm
MA-142	200 mm
MP-13	230 mm
MK-67	263 mm
MA-324	303 mm
MI-32	340 mm

item#	length
MA-38	375 mm
ML-35	420 mm
ML-05	480 mm
MK-11	458 mm
MA-70	515 mm
ML-21	610 mm

8.04mm



610mm
ME-35

Original Accessories

原廠周邊商品

ICS Glasses - International
ICS 運動眼鏡國際版

MS-178
YELLOW 鏡片黃

NEW



MS-179
YELLOW 鏡片透明

NEW



MS-171
YELLOW 灰鏡片

NEW



ICS Logo Sticker (50x9cm)
品牌貼紙 (50x9cm)

MS-163 Black 黑色
MS-164 White 白色

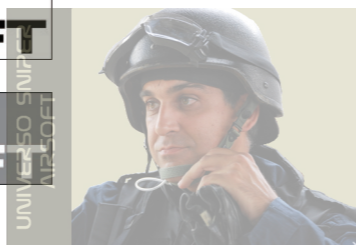

Bandan

戰術頭巾

Bandan A
戰術頭巾 A
MS-138



T-Shirt

服裝

T-Shirt ICS-WH
T-Shirt ICS- 白色
MS-141



T-Shirt ICS-BK
T-Shirt ICS- 黑色
MS-142



T-Shirt ICS-RD
T-Shirt ICS- 紅色
MS-143



Event Canopy
ICS 活動帳篷
MS-68



Reusable Shopping Bag
ICS 環保袋
MS-69



ID Landyard
ICS 識別證帶
MS-101



ICS 8 in 1 tool
ICS 8 合 1 工具組
MS-150



Tattoo Paper
紋身貼紙
MS-140



ICS Paper Fan
ICS 戰術扇
MS-177

NEW



T-Shirt CXP-BK
T-Shirt CXP- 黑色
MS-144



T-Shirt USA-GY
T-Shirt 美國國旗 - 灰色
MS-145



T-Shirt UK-BK
T-Shirt 英國國旗 - 黑色
MS-146



ICS Patch

品牌臂章

ICS Vest Patch
品牌胸口臂章

MS-137

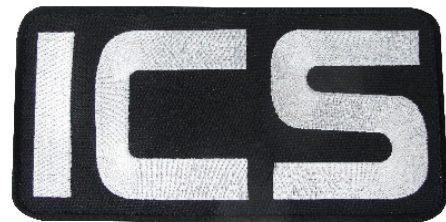

ICS Horizontal Patch
ICS 品牌橫式臂章色

MS-175



BLE Patch-BK
品牌臂章 -BLE- 黑色

MS-157



USA Patch
美國臂章

MS-176



ICS Japan Patch
ICS 日本臂章

MS-170



ICS CXP Patch-Green
品牌臂章 -CXP- 綠色

MS-56-2



ICS CXP Patch-TAN
品牌臂章 -CXP- 沙色

MS-53-2



ICS CXP Patch-BK
品牌臂章 -CXP- 黑色

MS-50-2



ICS PVC Patch-BK
品牌 PVC 臂章 - 黑色

MS-167



ICS Patch-BK
品牌臂章 -ICS- 黑色

MS-155



MARS Patch
MARS 臂章

MS-174



BLE Patch-TAN
品牌臂章 -BLE- 沙色

MS-158

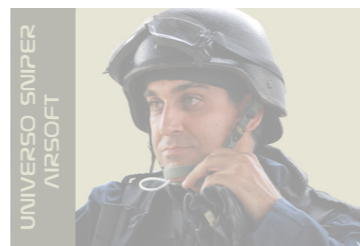

ICS Blood Type Patch-A
品牌血型臂章 -A

MS-133



ICS Blood Type Patch-B
品牌血型臂章 -B

MS-135



ICS PVC Patch-TAN
品牌 PVC 臂章 - 沙色

MS-168



ICS Patch-TAN
品牌臂章 -ICS- 沙色

MS-156



BLE Patch-GN
品牌臂章 -BLE- 綠色

MS-159



ICS Blood Type Patch-AB
品牌血型臂章 -AB

MS-134



Baseball Cap

休閒帽

Cap-GY
球帽 - 灰色

MS-147



Cap-GN
球帽 - 綠色

MS-148



Cap-TAN
球帽 - 沙色

MS-149



Series	Item	Model	Type	Receiver Material	Length (mm)	Weight (g)	Inner Barrel Length (mm)	Inner Barrel Bore Diameter (mm)	Gearbox Version	Factory Default Velocity	Stock Type	Magazine Capacity (rounds)	Color
CXP-08	ICS-324	CXP-08 EBB	EBB	Metal	695/595	2,900g	200mm	6.04mm	ICS Split EBB Gearbox 7mm Bushing	112-128 m/s (367-420 FPS)	QRS Stock	300	Black
	ICS-325	CXP-08 Crane Stock EBB	EBB	Metal	735/640	2,700g	200mm	6.04mm	ICS Split EBB Gearbox 7mm Bushing	112-128 m/s (367-420 FPS)	Crane Stock	300	Black
	ICS-160	CXP-08 Sport Line	AEG	Engineering Plastic	695/595	2,150g	200mm	6.04mm	ICS CS4 Split Gearbox 7mm Bushing	90-104 m/s (295-341 FPS)	QRS Stock	300	Black
	ICS-144	CXP-08 Crane Stock Sportline	AEG	Engineering Plastic	745/650	2,300g	200mm	6.04mm	ICS CS4 Split Gearbox 7mm Bushing	90-104 m/s (295-341 FPS)	Crane Stock	300	Black
	IPT-160-1	CXP-08 TAN Sportline	AEG	Engineering Plastic	695/595	2,150g	200mm	6.04mm	ICS CS4 Split Gearbox 7mm Bushing	90-104 m/s (295-341 FPS)	QRS Stock	300	Tan
CXP-15	ICS-171	CXP-15 Keymod	AEG	Metal	732/642	2,100g	200mm	6.04mm	ICS CS4 Split Gearbox 7mm Bushing	112-124 m/s (367-407 FPS)	Retractable Stock	300	Black
	ICS-173	CXP-15 Keymod Pistol	AEG	Metal	472	1,900g	200mm	6.04mm	ICS CS4 Split Gearbox 7mm Bushing	112-124 m/s (367-407 FPS)	N/A	300	Black
	ICS-175	CXP-15 Keymod Crane Stock	AEG	Metal	743/648	2,200g	200mm	6.04mm	ICS CS4 Split Gearbox 7mm Bushing	112-124 m/s (367-407 FPS)	Crane Stock	300	Black
	ICS-170	CXP-15 Keymod Sportline	AEG	Engineering Plastic	732/642	1,800g	200mm	6.04mm	ICS CS4 Split Gearbox 7mm Bushing	88-103 m/s (289-338 FPS)	Retractable Stock	300	Black
	ICS-172	CXP-15 Keymod Pistol Sportline	AEG	Engineering Plastic	472	1,600g	200mm	6.04mm	ICS CS4 Split Gearbox 7mm Bushing	88-103 m/s (289-338 FPS)	N/A	300	Black
CXP-16	ICS-174	CXP-15 Keymod Crane Stock Sportline	AEG	Engineering Plastic	778/683	1,900g	200mm	6.04mm	ICS CS4 Split Gearbox 7mm Bushing	88-103 m/s (289-338 FPS)	Crane Stock	300	Black
	ICS-238	CXP-16 L	AEG	Metal	980/885	3,300g	303mm	6.04mm	ICS CS4 Split Gearbox 7mm Bushing	116-136 m/s (381-446 FPS)	Crane Stock	300	Black
	IMT-238-1	CXP-16 L TAN	AEG	Metal	980/885	3,300g	303mm	6.04mm	ICS CS4 Split Gearbox 7mm Bushing	116-136 m/s (381-446 FPS)	Crane Stock	300	Tan
CXP-APE	ICS-230	CXP-APE	EBB	Metal	784/716	2,900g	263mm	6.04mm	ICS Split EBB Gearbox 7mm Bushing	115-130 m/s (377-427 FPS)	Retractable/ Folding Stock	300	Black
	ICS-231	CXP-APE R	EBB	Metal	895/827	3,000g	375mm	6.04mm	ICS Split EBB Gearbox 7mm Bushing	114-133 m/s (374-436 FPS)	Retractable/ Folding Stock	300	Black
	IMT-230-1	CXP-APE TAN	EBB	Metal	784/716	2,900g	263mm	6.04mm	ICS Split EBB Gearbox 7mm Bushing	115-130 m/s (377-427 FPS)	Retractable/ Folding Stock	300	Tan
	IMT-231-1	CXP-APE R TAN	EBB	Metal	895/827	3,000g	375mm	6.04mm	ICS Split EBB Gearbox 7mm Bushing	114-133 m/s (374-436 FPS)	Retractable/ Folding Stock	300	Tan
	IMD-230-1	CXP-APE Two Tone	EBB	Metal	784/716	2,900g	263mm	6.04mm	ICS Split EBB Gearbox 7mm Bushing	115-130 m/s (377-427 FPS)	Retractable/ Folding Stock	300	Two-Tone
	IMD-231-1	CXP-APE R Two Tone	EBB	Metal	895/827	3,000g	375mm	6.04mm	ICS Split EBB Gearbox 7mm Bushing	114-133 m/s (374-436 FPS)	Retractable/ Folding Stock	300	Two-Tone
	CXP-HOG	ICS-270	CXP-HOG MTR	EBB	Metal	795/700	3,000g	263mm	6.04mm	ICS Split EBB Gearbox 7mm Bushing	115-130 m/s (377-427 FPS)	MTR Stock	300
ICS-271		CXP-HOG MTR	EBB	Metal	795/720	3,000g	263mm	6.04mm	ICS Split EBB Gearbox 7mm Bushing	115-130 m/s (377-427 FPS)	MTR Stock	300	Black
ICS-272		CXP-HOG QRS	EBB	Metal	775/675	3,000g	263mm	6.04mm	ICS Split EBB Gearbox 7mm Bushing	115-130 m/s (377-427 FPS)	QRS Stock	300	Black
IMT-270-1		CXP-HOG TAN	EBB	Metal	795/700	3,000g	263mm	6.04mm	ICS Split EBB Gearbox 7mm Bushing	115-130 m/s (377-427 FPS)	MTR Stock	300	Tan
IMT-271-1		CXP-HOG TAN	EBB	Metal	795/720	3,000g	263mm	6.04mm	ICS Split EBB Gearbox 7mm Bushing	115-130 m/s (377-427 FPS)	MTR Stock	300	Tan
IMT-272-1		CXP-HOG QRS TAN	EBB	Metal	775/675	3,000g	263mm	6.04mm	ICS Split EBB Gearbox 7mm Bushing	115-130 m/s (377-427 FPS)	QRS Stock	300	Tan
ICS-274		CXP-HOG Tubular SR	EBB	Metal	910/880	3,300g	375mm	6.04mm	ICS Split EBB Gearbox 7mm Bushing	123-134 m/s (404-440 FPS)	QRS Stock	300	Black
ICS-275		CXP-HOG Tubular L SR	EBB	Metal	925/895	3,300g	375mm	6.04mm	ICS Split EBB Gearbox 7mm Bushing	121-134 m/s (397-440 FPS)	QRS Stock	300	Black
ICS-380		CXP-HOG Tubular SD MTR	EBB	Metal	880/800	2,860g	375mm	6.04mm	ICS Split EBB Gearbox 7mm Bushing	120-138 m/s (394-453 FPS)	QRS Stock	300	Black
ICS-381		CXP-HOG Tubular SD S1	EBB	Metal	900/810	2,920g	375mm	6.04mm	ICS Split EBB Gearbox 7mm Bushing	120-138 m/s (394-453 FPS)	QRS Stock	300	Black
ICS-382		CXP-HOG Tubular SD SR	EBB	Metal	880/910	3,300g	375mm	6.04mm	ICS Split EBB Gearbox 7mm Bushing	120-138 m/s (394-453 FPS)	QRS Stock	300	Black
ICS-383	CXP-HOG Tubular SSD MTR	EBB	Metal	800/720	2,690g	303mm	6.04mm	ICS Split EBB Gearbox 7mm Bushing	116-136 m/s (381-446 FPS)	QRS Stock	300	Black	
CXP-UK1	ICS-264C	CXP-UK1C	EBB	Metal	795/700	2,587g	263mm	6.04mm	ICS Integrated EBB Gearbox 7mm Bushing	123-133 m/s (404-436 FPS)	MTR Stock	300	Black
	ICS-263	CXP-UK1 Captain	EBB	Metal	512	2,630g	186mm	6.04mm	ICS Split EBB Gearbox 7mm Bushing	111-121 m/s (364-397 FPS)	N/A (Pistol Buffer Tube)	300	Black
	ICS-262	CXP-UK1 Captain MTR	EBB	Metal	693/617	2,840g	186mm	6.04mm	ICS Split EBB Gearbox 7mm Bushing	111-121 m/s (364-397 FPS)	MTR Stock	300	Black
	ICS-260	CXP-UK1	EBB	Metal	795/700	2,700g	261mm	6.04mm	ICS Split EBB Gearbox 7mm Bushing	117-135 m/s (384-443 FPS)	MTR Stock	300	Black
	IMT-264C-1	CXP-UK1C	EBB	Metal	795/700	2,587g	263mm	6.04mm	ICS Integrated EBB Gearbox 7mm Bushing	123-133 m/s (404-436 FPS)	MTR Stock	300	Tan
	IMT-263-1	CXP-UK1 Captain TAN	EBB	Metal	512	2,630g	186mm	6.04mm	ICS Split EBB Gearbox 7mm Bushing	111-121 m/s (364-397 FPS)	N/A (Pistol Buffer Tube)	300	Tan
	IMT-262-1	CXP-UK1 Captain MTR TAN	EBB	Metal	693/617	2,840g	186mm	6.04mm	ICS Split EBB Gearbox 7mm Bushing	111-121 m/s (364-397 FPS)	MTR Stock	300	Tan
	IMT-260-1	CXP-UK1	EBB	Metal	795/700	2,700g	261mm	6.04mm	ICS Split EBB Gearbox 7mm Bushing	117-135 m/s (384-443 FPS)	MTR Stock	300	Tan
	ICS-264	CXP-UK1	EBB	Metal	795/700	2,700g	261mm	6.04mm	ICS Split EBB Gearbox 7mm Bushing	117-135 m/s (384-443 FPS)	MTR Stock	300	Black
	ICS-265	CXP-UK1 R	EBB	Metal	906/811	2,920g	372mm	6.04mm	ICS Split EBB Gearbox 7mm Bushing	121-142 m/s (397-466 FPS)	MTR Stock	300	Black
	ICS-261	CXP-UK1 R	EBB	Metal	906/811	2,920g	372mm	6.04mm	ICS Split EBB Gearbox 7mm Bushing	121-142 m/s (397-466 FPS)	MTR Stock	300	Black
	IMT-264-1	CXP-UK1	EBB	Metal	795/700	2,700g	261mm	6.04mm	ICS Split EBB Gearbox 7mm Bushing	117-135 m/s (384-443 FPS)	MTR Stock	300	Tan
	IMT-265-1	CXP-UK1 R	EBB	Metal	906/811	2,920g	372mm	6.04mm	ICS Split EBB Gearbox 7mm Bushing	121-142 m/s (397-466 FPS)	MTR Stock	300	Tan
	IMT-261-1	CXP-UK1 R	EBB	Metal	906/811	2,920g	372mm	6.04mm	ICS Split EBB Gearbox 7mm Bushing	121-142 m/s (397-466 FPS)	MTR Stock	300	Tan

Series	Item	Model	Type	Receiver Material	Length (mm)	Weight (g)	Inner Barrel Length (mm)	Inner Barrel Bore Diameter (mm)	Gearbox Version	Factory Default Velocity	Stock Type	Magazine Capacity (rounds)	Color	
CXP-YAK	ICS-410	CXP-YAK C S1	EBB	Metal	825/733	3067	263	6.04mm	ICS Split EBB Gearbox 7mm Bushing	120 m/s (395fps)	MTR S1 Stock	300	Black	
	ICS-411	CXP-YAK S1	EBB	Metal	930/835	3145	375	6.04mm	ICS Split EBB Gearbox 7mm Bushing	120 m/s (395fps)	MTR S1 Stock	300	Black	
	ICS-412	CXP-YAK R SR	EBB	Metal	947	3617	420	6.04mm	ICS Split EBB Gearbox 7mm Bushing	120 m/s (395fps)	UKSR stock	300	Black	
	ICS-413	CXP-YAK CQB	EBB	Metal	838/743	3145	263	6.04mm	ICS Split EBB Gearbox 7mm Bushing	120 m/s (395fps)	MTR S1 Stock	300	Black	
	IMT-410-1	CXP-YAK C S1	EBB	Metal	825/733	3067	263	6.04mm	ICS Split EBB Gearbox 7mm Bushing	120 m/s (395fps)	MTR S1 Stock	300	Tan	
	IMT-411-1	CXP-YAK S1	EBB	Metal	930/835	3145	375	6.04mm	ICS Split EBB Gearbox 7mm Bushing	120 m/s (395fps)	MTR S1 Stock	300	Tan	
	IMT-412-1	CXP-YAK R SR	EBB	Metal	947	3617	420	6.04mm	ICS Split EBB Gearbox 7mm Bushing	120 m/s (395fps)	UKSR stock	300	Tan	
	IMT-413-1	CXP-YAK CQB	EBB	Metal	838/743	3145	263	6.04mm	ICS Split EBB Gearbox 7mm Bushing	120 m/s (395fps)	MTR S1 Stock	300	Tan	
	CXP-MARS	ICS-300	CXP-MARS Komodo	EBB	Metal	935/840	3160	375	6.04mm	ICS Split EBB Gearbox 7mm Bushing	120 m/s (395 FPS)	MTR S1 Stock	300	Black
		ICS-301	CXP-MARS SBR	EBB	Metal	800/705	2940	263	6.04mm	ICS Split EBB Gearbox 7mm Bushing	120 m/s (395 FPS)	MTR Stock	300	Black
ICS-302		CXP-MARS Carbin	EBB	Metal	905/810	3040	375	6.04mm	ICS Split EBB Gearbox 7mm Bushing	120 m/s (395 FPS)	MTR Stock	300	Black	
ICS-303		CXP-MARS DMR	EBB	Metal	980/980	3610	458	6.04mm	ICS Split EBB Gearbox 7mm Bushing	120 m/s (395 FPS)	UKSR stock	300	Black	
IMT-300-1		CXP-MARS Komodo	EBB	Metal	935/840	3160	375	6.04mm	ICS Split EBB Gearbox 7mm Bushing	120 m/s (395 FPS)	MTR S1 Stock	300	Tan	
IMT-301-1		CXP-MARS SBR	EBB	Metal	800/705	2940	263	6.04mm	ICS Split EBB Gearbox 7mm Bushing	120 m/s (395 FPS)	MTR Stock	300	Tan	
IMT-302-1		CXP-MARS Carbin	EBB	Metal	905/810	3040	375	6.04mm	ICS Split EBB Gearbox 7mm Bushing	120 m/s (395 FPS)	MTR Stock	300	Tan	
IMT-303-1		CXP-MARS DMR	EBB	Metal	980/980	3610	458	6.04mm	ICS Split EBB Gearbox 7mm Bushing	120 m/s (395 FPS)	UKSR stock	300	Tan	
IMD-300-1		CXP-MARS Komodo	EBB	Metal	935/840	3160	375	6.04mm	ICS Split EBB Gearbox 7mm Bushing	120 m/s (395 FPS)	MTR S1 Stock	300	Two-Tone	
IMD-301-1		CXP-MARS SBR	EBB	Metal	800/705	2940	263	6.04mm	ICS Split EBB Gearbox 7mm Bushing	120 m/s (395 FPS)	MTR Stock	300	Two-Tone	
IMD-302-1	CXP-MARS Carbin	EBB	Metal	905/810	3040	375	6.04mm	ICS Split EBB Gearbox 7mm Bushing	120 m/s (395 FPS)	MTR Stock	300	Two-Tone		
IMD-303-1	CXP-MARS DMR	EBB	Metal	980/1010	3610	458	6.04mm	ICS Split EBB Gearbox 7mm Bushing	120 m/s (395 FPS)	UKSR stock	300	Two-Tone		
MAR Series	ICS-32	MAR R.A.S.	AEG	Metal	965	3,200g	458mm	6.04mm	Gill 7mm Bushing	115-137 m/s (377-449 FPS)	Fixed Stock	550	Black	
	ICS-36	MAR Wooden Stock	AEG	Metal	960	3,314g	458mm	6.04mm	Gill 7mm Bushing	115-137 m/s (377-449 FPS)	Fixed Wooden Stock	550	Black	
	ICS-35	MAR M	AEG	Metal	964/714	3,000g	458mm	6.04mm	Gill 7mm Bushing	115-137 m/s (377-449 FPS)	Folding Stock	550	Black	
	ICS-34	MAR SU	AEG	Metal	745/510	2,700g	263mm	6.04mm	Gill 7mm Bushing	115-134 m/s (377-440 FPS)	Folding Stock	550	Black	
CES Series	ICS-37	MAR SN	AEG	Metal	960/715	3,100g	458mm	6.04mm	Gill 7mm Bushing	122-137 m/s (400-449 FPS)	Folding Stock	550	Black	
	ICS-01	CES SD5	AEG	Metal	780	2,240g	230mm	6.04mm	Gill 7mm Bushing	112-122 m/s (367-400 FPS)	Fixed Stock	230	Black	
	ICS-02	CES SD6	AEG	Metal	740.5/600	2,300g	230mm	6.04mm	Gill 7mm Bushing	112-122 m/s (367-400 FPS)	Retractable Stock	230	Black	
	ICS-03	CES A4	AEG	Metal	680	2,300g	230mm	6.04mm	Gill 7mm Bushing	112-122 m/s (367-400 FPS)	Fixed Stock	230	Black	
CS4 Proline	ICS-04	CES A5	AEG	Metal	640/500	2,000g	230mm	6.04mm	Gill 7mm Bushing	112-122 m/s (367-400 FPS)	Retractable Stock	230	Black	
	ICS-320	CS4A1 EBB	EBB	Metal	873/778	2,900g	375mm	6.04mm	ICS Split EBB Gearbox 7mm Bushing	120-138 m/s (394-453 FPS)	Retractable Stock	450	Black	
	ICS-321	CS4 R.I.S. EBB	EBB	Metal	815/730	3,250g	263mm	6.04mm	ICS Split EBB Gearbox 7mm Bushing	116-132 m/s (382-433 FPS)	Crane Stock	450	Black	
	ICS-322	CS4 Tubular R.A.S. L	EBB	Metal	873/778	3,000g	375mm	6.04mm	ICS Split EBB Gearbox 7mm Bushing	120-138 m/s (394-453 FPS)	MTR Stock	450	Black	
	ICS-323	CS4 Tubular R.A.S. S	EBB	Metal	873/778	2,950g	375mm	6.04mm	ICS Split EBB Gearbox 7mm Bushing	120-138 m/s (394-453 FPS)	MTR Stock	450	Black	
	ICS-220	CS4 Tubular R.A.S. L	AEG	Metal	873/778	2,900g	375mm	6.04mm	ICS CS4 Split Gearbox 7mm Bushing	115-140 m/s (377-459 FPS)	Retractable Stock	450	Black	
	ICS-221	CS4 Tubular R.A.S. S	AEG	Metal	873/778	2,850g	375mm	6.04mm	ICS CS4 Split Gearbox 7mm Bushing	115-140 m/s (377-459 FPS)	Retractable Stock	450	Black	
	ICS-24	CS16A3	AEG	Metal	1025	3,370g	515mm	6.04mm	ICS CS4 Split Gearbox 7mm Bushing	117-142 m/s (384-466 FPS)	Fixed Stock	450	Black	
	ICS-30	CS16A3 R.A.S.	AEG	Metal	1025	3,750g	515mm	6.04mm	ICS CS4 Split Gearbox 7mm Bushing	117-142 m/s (384-466 FPS)	Fixed Stock	450	Black	
	ICS-20	CS4A1	AEG	Metal	873/778	3,000g	375mm	6.04mm	ICS CS4 Split Gearbox 7mm Bushing	115-140 m/s (377-459 FPS)	Retractable Stock	450	Black	
CS4 Sportline	ICS-127	CS4 R.I.S. Commando	AEG	Metal	815/730	3,000g	263mm	6.04mm	ICS CS4 Split Gearbox 7mm Bushing	113-130 m/s (371-427 FPS)	Crane Stock	450	Black	
	IPT-047-1	CS4 R.I.S. Commando TAN Sportline	AEG	Engineering Plastic	815/730	2,500g	263mm	6.04mm	ICS CS4 Split Gearbox 7mm Bushing	94-109 m/s (308-358 FPS)	Crane Stock	300	Tan	
	ICS-41	CS4A1 Sport Line	AEG	Engineering Plastic	873/7									

Series	Item	Model	Type	Receiver Material	Length (mm)	Weight (g)	Inner Barrel Length (mm)	Inner Barrel Bore Diameter (mm)	Gearbox Version	Factory Default Velocity	Stock Type	Magazine Capacity (rounds)	Color
L85/86 Series	ICS-86	L86A2	AEG	Metal	912.8	4,411g	610mm	6.04mm	ICS L85 Gearbox 7mm Bushing	115-133 m/s (377-436 FPS)	Fixed Stock	450	Black/Olive
	ICS-85	L85A2	AEG	Metal	786.5	3,652g	480mm	6.04mm	ICS L85 Gearbox 7mm Bushing	116-139 m/s (382-456 FPS)	Fixed Stock	450	Black/Olive
	ICS-87	L85A2 CARBINE	AEG	Metal	740	3,090g	420mm	6.04mm	ICS L85 Gearbox 7mm Bushing	118-136 m/s (387-446 FPS)	Fixed Stock	450	Black/Olive
MGL Series	ICS-190	MGL	Multiple Grenade Launcher	Engineering Plastic	725/630	2,200g	200mm	40mm	N/A	Depending on grenade	Retractable Stock	Depending on grenade	Black
	ICS-191	MGL Tan		Engineering Plastic	780/675	2,200G	200mm	40mm			Crane Stock		Tan
	ICS-193	MGL S		Metal Handguard/ Reinforced Plastic	725/630	2,400g	200mm	40mm			Retractable Stock		Black
	ICS-192	MGL L		Metal Handguard/ Reinforced Plastic	825/725	2,700g	295mm	40mm			Retractable Stock		Black
TOD Series	ICS-91	TOD ARM	AEG	Metal	980/750	3,500g	515mm	6.04mm	TOD 7mm Bushing	117-138 m/s (385-453 FPS)	Folding Stock	400	Black
	ICS-96	TOD MRS	AEG	Metal	980/750	3,860g	515mm	6.04mm	TOD 7mm Bushing	117-138 m/s (385-453 FPS)	Folding Stock	400	Black
	ICS-92	TOD AR	AEG	Metal	980/750	3,000g	515mm	6.04mm	TOD 7mm Bushing	117-138 m/s (385-453 FPS)	Folding Stock	400	Black
WWII Series	ICS-200	M3 Submachine Gun	AEG	Metal	762.5/587	2,045g	230mm	6.04mm	ICS M3 Gearbox 8mm Bushing	115-128 m/s (377-420 FPS)	Retractable Stock	430	Black
	ICS-202	M1 Grand	AEG	Metal	1100	3,600g	610mm	6.04mm	ICS M1 Gearbox 8mm Bushing	118-135 m/s (387-443 FPS)	Fixed Wooden Stock	42	Black
	ICS-201L	M1 Grand Golden Limited Version	AEG	Metal	1100	3,600g	610mm	8.04mm	ICS M1 Gearbox 8mm Bushing	80-87 m/s (262-285 FPS)	Fixed Wooden Stock	25	Golden
AAR Series	ICS-235	AAR Two Tone	AEG	Engineering Plastic	515/746/795	2,550g	263mm	6.04mm	Gill 7mm Bushing	115-134 m/s (377-440 FPS)	Retractable/Folding Stock	300	Two-Tone
	ICS-233	AAR	AEG	Engineering Plastic	515/746/795	2,550g	263mm	6.04mm	Gill 7mm Bushing	115-134 m/s (377-440 FPS)	Retractable/Folding Stock	300	Black
	ICS-234	AAR Tan	AEG	Engineering Plastic	515/746/795	2,550g	263mm	6.04mm	Gill 7mm Bushing	115-134 m/s (377-440 FPS)	Retractable/Folding Stock	300	Tan
MMR Series	ICS-400	MMR SBR	EBB	Metal	975	3,393g	458	6.14mm	ICS Split EBB Gearbox 7mm Bushing	120 m/s (395fps)	UKSR stock	300	Black
	ICS-401	MMR Carbine	EBB	Metal	835/930	2,886g	375	6.14mm	ICS Split EBB Gearbox 7mm Bushing	120 m/s (395fps)	MTR S1 Stock	300	Black
	ICS-402	MMR DMR	EBB	Metal	725/800	2,678g	263	6.04mm	ICS Split EBB Gearbox 7mm Bushing	120 m/s (395fps)	MTR Stock	300	Black
	IMT-400-1	MMR SBR TAN	EBB	Metal	975	3,393g	458	6.14mm	ICS Split EBB Gearbox 7mm Bushing	120 m/s (395fps)	UKSR stock	300	Tan
	IMT-401-1	MMR Carbine TAN	EBB	Metal	835/930	2,886g	375	6.14mm	ICS Split EBB Gearbox 7mm Bushing	120 m/s (395fps)	MTR S1 Stock	300	Tan
	IMT-402-1	MMR DMR TAN	EBB	Metal	725/800	2,678g	263	6.14mm	ICS Split EBB Gearbox 7mm Bushing	120 m/s (395fps)	MTR Stock	300	Tan

Series	Item	Model	Type	Slide Material	Length (mm)	Weight (g)	Inner Barrel Length (mm)	Inner Barrel Bore Diameter (mm)	Factory Default Velocity	Magazine Capacity (rounds)	Color
BLE XAE SERIES	BLE-006-SB	BLE-XAE GBB Pistol Black	GBB	Engineering Plastic	184.5	670g	85.5mm	6mm	90 m/s	24+1	Black
	BLE-006-ST	BLE-XAE GBB Pistol Tan	GBB	Engineering Plastic	184.5	670g	85.5mm	6mm	90 m/s	24+1	Tan
	BLE-006-SG	BLE-XAE GBB Pistol Gray	GBB	Engineering Plastic	184.5	670g	85.5mm	6mm	90 m/s	24+1	Gray
	BLE-006-SE	BLE-XAE GBB Pistol DE	GBB	Engineering Plastic	184.5	670g	85.5mm	6mm	90 m/s	24+1	DE
	BLE-006-SD3	BLE-XAE GBB Pistol Two-Tone BKTN	GBB	Engineering Plastic	184.5	670g	85.5mm	6mm	90 m/s	24+1	Two-Tone BKTN
	BLE-006-SD4	BLE-XAE GBB Pistol Two-Tone TNBK	GBB	Engineering Plastic	184.5	670g	85.5mm	6mm	90 m/s	24+1	Two-Tone TNBK
	BLE-006-SD5	BLE-XAE GBB Pistol Two-Tone GRNT	GBB	Engineering Plastic	184.5	670g	85.5mm	6mm	90 m/s	24+1	Two-Tone GRNT
BLE XFG SERIES	BLE-006-SD6	BLE-XAE GBB Pistol Two-Tone DKBK	GBB	Engineering Plastic	184.5	670g	85.5mm	6mm	90 m/s	24+1	Two-Tone DKBK
	BLE-005-SB	XFG Gas Blowback Pistol Black	GBB	Engineering Plastic	183	580g	86mm	6mm	90m/s	21+1	Black
	BLE-005-ST	XFG Gas Blowback Pistol Tan	GBB	Engineering Plastic	183	580g	86mm	6mm	90m/s	21+1	Tan
	BLE-005-SH	XFG Gas Blowback Pistol Hairline	GBB	Engineering Plastic	183	580g	86mm	6mm	90m/s	21+1	Hairline
	BLE-005-SD1	XFG Gas Blowback Pistol Two-Tone BKTN	GBB	Engineering Plastic	183	580g	86mm	6mm	90m/s	21+1	Two-Tone BKTN
	BLE-005-SD2	XFG Gas Blowback Pistol Two-Tone TNBK	GBB	Engineering Plastic	183	580g	86mm	6mm	90m/s	21+1	Two-Tone TNBK

 瓦斯動力系統 GBB system	 電動動力系統 AEG system	 EBB系統 EBB System	 金屬槍身 Metal receiver	 塑膠槍身 Plastic receiver	 8mm培林BOX 8mm bushing box	 7mm培林BOX 7mm bushing box	 6mm BB彈 6mm BB pellet	 8mm BB彈 8mm BB pellet
 M120彈簧 M120 spring	 M100彈簧 M100 spring	 430連彈匣 430 pellets mag.	 ICS 分離式BOX ICS Split gearbox	 一體式齒輪箱 Combination Gearbox	 ICS 3號BOX ICS Ver III gearbox	 ICS L85 BOX ICS L85 gearbox	 ICS M1 BOX ICS M1 gearbox	 ICS M3 BOX ICS M3 gearbox
 勿朝路人射擊 Fire to onlooker prohibition	 勿朝動物射擊 Fire to animal prohibition	 兒童請勿使用 Children prohibition	 請勿吞食 Swallow prohibition	 請配戴護目鏡 Please wear the eye protection	 請詳閱說明書 Please refer to the manual	 40mm榴彈 40mm grenade	 長軸馬達 Motor (long axis)	 H-UP系統 H-UP adjustable



Please contact ICS for the information of worldwide distributors in NAFTA, Latin America, Europe, Africa, Asia and Oceania.
「創新科技、創意休閒」 「尊重人性、追求卓越」 「永續經營、共享共榮」

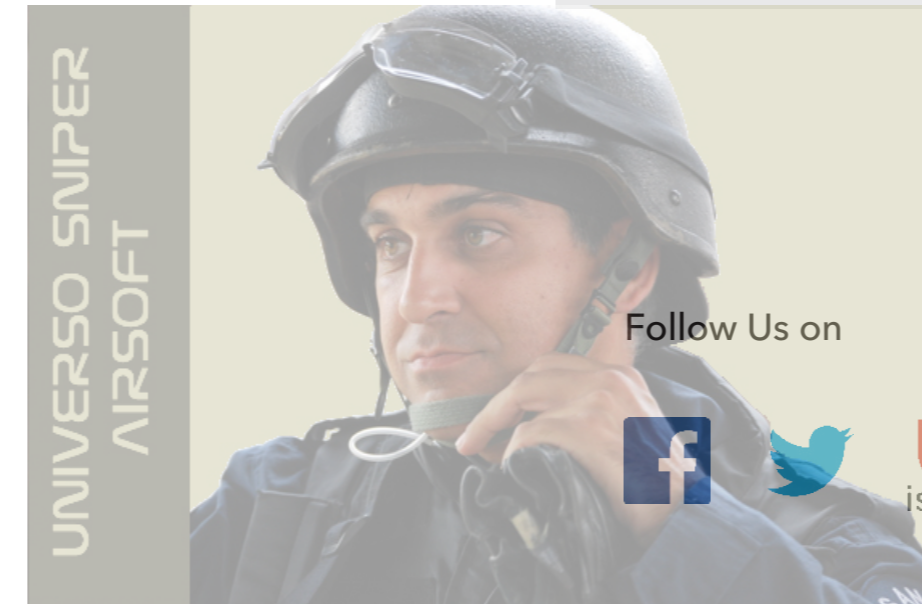

Follow Us on



ICS Airsoft



ICS AEGs



@icsbbairsoft

